

# Mobile Air Quality Monitoring System

Ms. Shilpa Ramdas Tambade<sup>1</sup>, Prof. Sandip B. Rahane<sup>2</sup>

<sup>1</sup>Student, Electronics Engineering Department, Amrutvahini College of Engineering, Sangamner

<sup>2</sup>Professor, Electronics Engineering Department, Amrutvahini College of Engineering, Sangamner

**Abstract-** Mobile Air Quality Monitoring System is a moving system to monitor air quality in different areas wherever you go, or the area you want to monitor. You just have to put your sensing system at some place in that area or fix it to a surveillance vehicle. This system is able to detect quantity of CO, NH<sub>3</sub>, SO<sub>2</sub>, temperature and humidity. This data is displayed on the laptop for the convenience of pollution control authorities.

**Index terms-** Air pollution, Embedded system, GPS, GSM

## I. INTRODUCTION

Though it is not very new issue now-a-days, air pollution is surely a vital problem causing damage not only to the mankind but also to the flora and fauna, and the entire environment. As we all know air pollution causes serious issues such as human health problems including breathing diseases, heart diseases, lung diseases and several types of cancers. Air pollution leads to greenhouse effects, acid rains, eutrophication. As well as air pollution affects on forest as well as aquatic animals in different ways like birth defects, reproductive failure.[6]

We need to control it and for that first we need to monitor it. We have so many air quality monitoring systems but those are quite tricky and expensive. Every civilian should be aware of air pollution, its causes, its effects, and what a normal person can do to remedy it. Contribution of every single person to overcome this problem will result in a great achievement.

Thus, this system is evolved not only for technological or official use but to create awareness in public. The system consists of sensing subunit, monitoring unit and people awareness android mobile app.

## II. LITERATURE SURVEY

The various researches have analyzed different issues, developed and implement various systems

with its basic features, advantages, disadvantages and applications. The review of some of researches in his paper is given below,

Particle pollution is an increasingly important problem worldwide and causing severe issue to human health especially in indoor environment. Now a days, people have assembled advanced sensing and control technologies in their modern homes, which offers control and optimization capabilities for numerous parameters. The present system has an open platform of a Wi-Fi-enabled indoor air quality monitoring and control system. This system has facilities to embed it with a 'smart building' structure. The system operates over an existing Wi-Fi wireless network utilizing the MQTT protocol. This system monitors the indoor air quality and controls an air purifier to maintain the particle pollutants concentration [1].

Researchers have introduced outdoor air quality monitoring system based on ZigBee wireless sensor network. A wireless network contains coordinators, routers, terminal nodes and high precision sensors (PPB). Data is collected and processed by terminal nodes. Then it is transmitted to routers or the coordinator via a serial port, and then displayed on a monitor. The system provides online real time observation of amount of CO, SO<sub>2</sub>, O<sub>3</sub>, NO<sub>2</sub> and NO present into the air. The hardware, software and system architecture are designed using ZigBee wireless sensor network.

Traditional systems of air quality monitoring were using single networking parameter which offered limited functionality. But modern wireless sensor networks involve multi-disciplinary devices. There are various wireless networks such as Wi-Fi, Bluetooth, Wireless USB, ZigBee, etc. Zig Bee devices based on the IEEE 802.15.4 standard are being used vastly for cheap, power immune and simple communication applications. The devices in the network are divided into three categories

according to their functions i.e. coordinators, routers, and terminal nodes. The coordinator starts the ZigBee network. It scans for all radio channels during the initializing phase of network so that it could find the ideal radio channel. When the terminal node starts, they scans for available radio channels to connect with the most suitable channel. Terminal nodes gather the data and send to the routers or coordinators via serial port and then the data is displayed on the monitor [2].

There is a system which presents an IOT-based air pollution monitoring and data analysis system for ambient air monitoring. This system is based on LPWAN and LoRa technologies. This system uses a wireless sensor network to collect air quality data. This system has unceasing power supply by using solar PV-battery part. It is easy to operate, cheap, it covers long and high distance, as well as it has self-sustainable long life high capacity batteries. It provides highly accurate results within very less response time. Because of LoRa Wireless Communication technology the system provides real-time quantity of pollutants present in air with low power surveillance system. The system consists of a single-chip microcontroller, various gas sensors (NO<sub>2</sub>, SO<sub>2</sub>, O<sub>3</sub>, CO, PM<sub>1</sub>, PM<sub>10</sub>, PM<sub>2.5</sub>), Long-range (LoRa) -Modem, a solar PV-battery part and graphical user interface (GUI). The data is sent to the central device using communication module LoRa which saves it to the cloud. Range of LoRa is approximately 2 Km. Sensing module incorporates one microcontroller, gas and PM sensors (NO<sub>2</sub>, SO<sub>2</sub>, O<sub>3</sub>, CO, PM<sub>1</sub>, PM<sub>10</sub>, PM<sub>2.5</sub>) unit and wirelessly connected LPWAN node. To convert the analogue readings from the sensors into the digital values the 32 bit STM is used. Then LoRa modem sends the data to LPWAN nodes. At last, all data from the network nodes is received by the control units attached to the computer. At the base station data is processed and display software presents all data information on the GUI. Data processing and display software provides all the past and present information regarding air quality of the various locations [3].

In the Haze Watch system multiple low-cost mobile sensor units attached to vehicles are used to monitor air pollutants, and this data is uploaded in real time using users' mobile phones. Using collected data, real time on web pollution maps of metropolitan Sydney are created. The personalized or mobile app shows

the individual's exposure history and help to route the plan to minimize future hazards. The data collection architecture in the Haze Watch project is based upon the "crowd-sourcing" or "participatory sensing". Each user collects air pollution data using personal sensing units and contributes it with all users, and the greater spatial density of data collected from each user gives more accurate estimates of their pollution level to all users [4].

### III. SYSTEM ARCHITECTURE

Hardware of the system consists of monitoring unit and a sensing subunit which is mobile i.e. movable from one place to another.

#### 1. Sensing Subunit

Sensing subunit has gas sensors, temperature sensor, humidity sensor and their respective signal conditioning circuits. The gas sensors are MQ7 for CO i.e. carbon monoxide, MQ135 for NH<sub>3</sub> i.e. Ammonia and as sensors for SO<sub>2</sub> i.e. Sulfur dioxide are expensive for student level this is simulated. For temperature sensing LM35 sensor is used. As sensitivity of LM35 is 2mV/ °C, there is no need of signal conditioning circuit for LM35. For humidity SY HS 230 sensor is used.

#### 2. Monitoring Unit

Monitoring system is microcontroller, local display and a laptop which displays all the air pollution data. Here ARM 2138 microcontroller is used for its multiple features like inbuilt 10 bit ADC, On-chip SRAM, On-chip flash program memory, UARTs etc. Data received from sensing subunit is processed by microcontroller and displayed on 16\*2 LCD display. Using XCTU serial communication utility this data is sent to the laptop where this data is displayed.

MAX 232 is a line driver which has dual transceiver i.e. it can send and receive data to/from two devices simultaneously. Thus both GPS module and GSM MODEM are interfaced through MAX 232 IC. GPS module continuously keeps receiving the current location of hardware unit. GSM modem sends SMS to the registered mobile after every fixed time interval. If mobile user gives a missed call to the number in the GSM module it will immediately send data to the user over SMS.

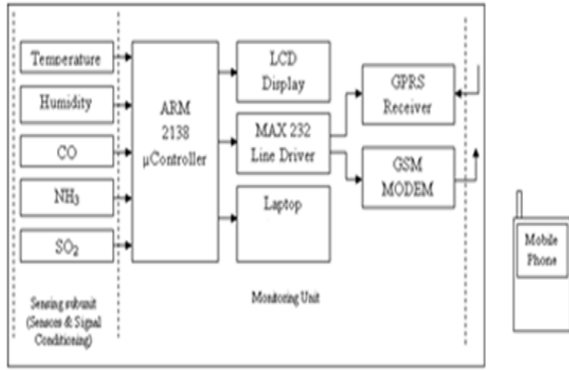

Fig. 1: Hardware Architecture

Fig. 1 shows hardware architecture of the system. Visual Basic is used as GUI. Pollution data is sent to the laptop using serial communication. It is accessed in VB using Hyperterminal utility.

IV. WORKING

Pollutant sensors will sense the parameters and produce the output in terms of electric signal i.e. voltage which will be very small value. Hence this signal needs to conditioning and amplifying. Signal conditioning section will condition each signal independently. That means each sensor will have its own signal conditioning circuit. After conditioning the signal, it will be sent to the Microcontroller i.e. LPC 2138 ARM Processor. Now processor will process the data and send it to the user end. This data is sent to two user ends.

1. User Mobile: Pollution data is sent to the mobile of authorized users only by SMS using GSM module.
2. Laptop/ Central Unit: Pollution data is sent to the laptop using serial communication. And it is displayed on GUI system.

GPS subunit provides latitude and longitude of the location in which our system is working. This data is also displayed on user ends.

SMS Facility: There is one toggle switch on hardware to enable SMS facility. When this is enabled SMS will be sent to your authorized mobile number. When it disabled SMS wouldn't be sent automatically. In this mode of operation if you call from authorized mobile no to the mobile number which is inserted into GSM module, then GSM module will send you SMS. Fig. 2 shows the flowchart of this system.

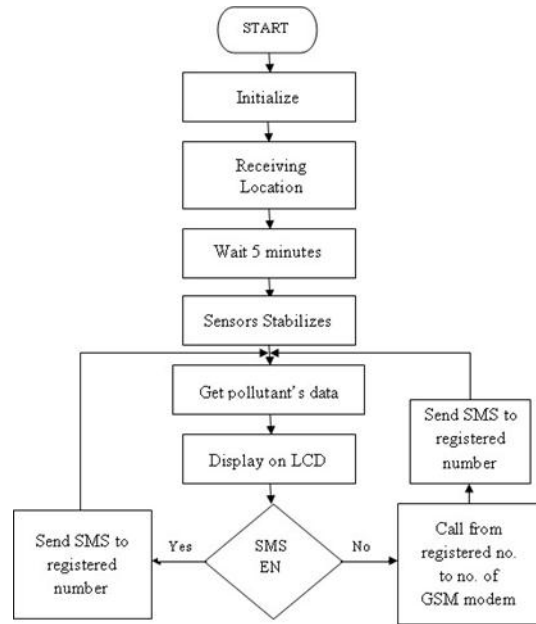

Fig. 2: Flowchart of SMS Unit

V. RESULT

Parameters →		CO	NH3	Temp	Humi dity
Location ↓		1 – 70 ppm	20 ppm		
Sangam ner	1961.4 418, N 7418.4 859, E	6 ppm	2 ppm	37°C	33%
Koparg aon	1988.3 783, N 7440.1 422, E	2 ppm	3 ppm	38°C	27%
Mira Road (Mumb ai)	1928.2 162, N 7284.1 517, E	10 ppm	6 ppm	32°C	68%



Fig. 2: VB Front end Screen

VI. CONCLUSION AND FURTHER WORK

This system is try to develop simple, more reliable, cost efficient and movable model to measure air quality. This system can gather data from various locations so that we don't have to deploy multiple systems in different areas.

There is vast scope for future development in this system. To increase no of pollutant sensors to sense much more pollutant gases is the main scope. To develop database and get all historical report, analysis of the data is another scope. As well to develop mobile app to show the live data to all app user is in our scope.

[7] Navreetinder Kaur, Rita Mahajan, Deepak Bagai, "Air Quality Monitoring System based on Arduino Microcontroller", International Journal of Innovative Research in Science, Engineering and Technology, Vol. 5, Issue 6, June 2016.

#### REFERENCES

- [1] Xiaoke Yang; Lingyu Yang; Jing Zhang (July 2017), " A WiFi-enabled Indoor Air Quality Monitoring and Control System: the Design and Control Experiments", 13th IEEE International Conference on Control & Automation (ICCA), July 3-6, 2017.
- [2] Yun-Liang Hel, Shu-Qin Gengl, Xiao-Hong Pengl, Li-Gang Hou, Xiang-Kai Gao, Jin-Hui Wang, "Design of Outdoor Air Quality Monitoring System Based on ZigBee Wireless Sensor Network". 13th IEEE International Conference on Solid-State and Integrated Circuit Technology (ICSICT), 2016.
- [3] Sujuan Liu, Chuyu Xia, Zhenzhen Zhao, "A Low-power Real-time Air Quality Monitoring System Using LPWAN based on LoRa", 13th IEEE International Conference on Solid-State and Integrated Circuit Technology (ICSICT), 2016.
- [4] Vijay Sivaraman, James Carrapetta, Ke Hu, Blanca Gallego Luxan, " HazeWatch: A Participatory Sensor System for Monitoring Air Pollution in Sydney", 38th Annual IEEE Conference on Local Computer Networks - Workshops, 2013.
- [5] Abdelaziz El Fazziki, Djamal Benslimane, Abderrahmane Sadiq, Jamal Ouarzazi And Mohamed Sadgal, "An Agent Based Traffic Regulation System for the Roadside Air Quality Control", IEEE Journals & Magazines, Volume 5, 2017.
- [6] <http://www.mass.gov/eea/docs/dep/air/aq/health-and-env-effects-air-pollutions.pdf>.