

Camera Enabled Intelligent Safety System for Women Enhanced with Anesthetic Spray

Dr. Sharmila Durai¹, Sharmikha Varsha S², Swetha V³, Yogasree Nagaraj⁴

¹Associate Professor, Department of Electronics and Communication Engineering, RMD Engineering College, Affiliated to Anna University, Chennai, India

^{2,3,4}U.G Students, Department of Electronics and Communication Engineering, RMD Engineering College, Affiliated to Anna University, Chennai, India

Abstract- Women safety has been a big concern and it has been the most important duty of every person. There is no chance of the welfare of the world unless the condition of the women is improved. Women all over the world are facing much unethical physical harassment. In India, every day more than 30 women were murdered and many more are suffering acute mental and physical trauma. It is estimated that 35% of the women have experienced physical and/or sexual violence at some point in their lives. In our project we are proposing a security system for women at times of possible harassment in public places using Raspberry pi. The Raspberry pi is interfaced with piezoelectric plate which is going to be placed in the sole of the shoe during the time of harassment the wearer must tap the piezoelectric plate or resort to immediately pressing the keypad, doing this, an intimation will be sent. The sensor data will be immediately sent to the Raspberry pi and automatically it will start the video call and a message alert will be sent to the nearest police station and necessary persons.

Index terms- Anaesthetic spray, GPS, Piezoelectric plate, Women safety

I. INTRODUCTION

In Today's World the safety of women is in danger especially in India. The rate of crimes against women is not decreasing but in fact increasing at an alarming rate especially harassment, molestation, eve-teasing, rape, kidnapping and domestic violence. Many preventive measures have been taken by the government to stop these misbehaving activities but still has not affected the growing rate of these crimes and has remained unaffected. The problem of sexual harassment in work place is increasingly coming out day-by-day. Sexual harassment at a workplace is unwanted behavior of a person that causes

discomfort, offence or distress to the other. Majority of such cases are happened to woman by men working at high position in an organization. Women is getting kidnapped at every 44 minutes, raped at every 47 minutes, 17 dowry deaths every day. The fear of harassment against women is not only the condition at outside but it may also happen at homes. Women are not so physically fit as compared to men so in case of a need a helping hand would be a boon for them. Students face incidents like child trafficking and kidnapping, when they are waiting to embark or disembark a school bus. Sometimes here might be a situation that when women had an accident in the late night and there are no one to help them. In such situations the person will not be able to tell the situation that he/she facing. And they do not know the basic first-aid details and to know the person where the incident has happened. This system proposes a quick responding mechanism that helps women during trouble. When someone is harassing them, she can press keypad or tapping piezo plate that is attached to the device and the location information is sent as a message alert to pre-defined emergency numbers in terms of latitude and longitude.

II. SYSTEM OVERVIEW

To develop a smart device which can help women in some emergency situations and to provide a reliable security system for women when they are alone or unsafe. This device can be integrated into our daily life in the form a shoe, whenever, the woman feels threatened they can press the keypad or tap their toes, which will, in turn, release the anesthetic spray. This device mainly lies on two main components raspberry pi and PIC microcontroller.

RASPBERRY PI: It is a credit card-sized computer originally designed for education. The idea of the Compute Module was to provide an easy and cost-effective route to producing customized products based on the Pi hardware and software platform. The Module takes care of the complexity of routing out the processor pins, the high speed RAM interface, and core power supply, and allows a simple carrier board to provide just what is needed in terms of external interfaces and form factor. The raspberry pi board comprises a program memory (RAM), processor and graphics chip, CPU, GPU, Ethernet port, GPIO pins, xbee socket, UART, power source connector. And various interfaces for other external devices. It also requires mass storage, for that we use an SD flash memory card. So that raspberry pi board will boot from this SD card similarly as a PC boots up into windows from its hard disk.



Fig.1.Raspberry Pi

PIC MICROCONTROLLER: The main reasons for choosing 16F887 are it follows Harvard architecture with RISC Instruction set, speed, Timer Resources, Interrupt control and Robustness.

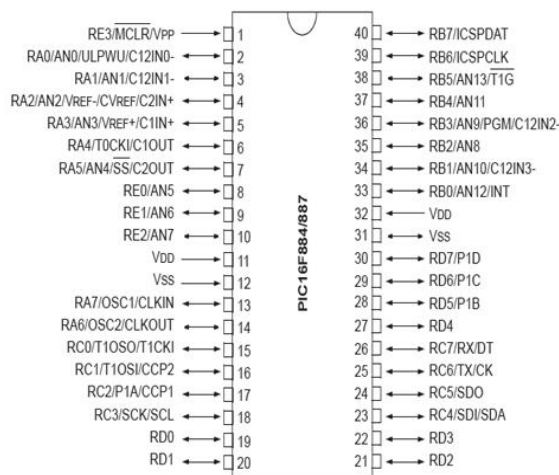

Fig.2.Pin diagram of PIC16F884

Features of PIC16F884:

- Operating speed:20Mhz, 200ns instruction cycle
- Operating voltage:4.0-5.5volts
- 15 Interrupt sources
- Flash memory:14.3KB(8192 words)
- Data RAM:368 bytes
- Data EEPROM:256 bytes
- 33 I/O pins : 5 I/O ports
- Timer0:8-bit timer/counter with 8-bit pre scaler
- Timer1:16-bit timer/counter with pre scaler
- Timer2:8-bit timer/counter with 8-bit period register, pre scaler and post scaler
- Two capture, compare, PWM modules
- Synchronous serial port with two modes
- USART/SCI with 9-bit address detection
- Parallel slave port
- 10-bit, 8-channel A/D converter

III. PREVIOUS WORK

The existing system makes use of GPS, GSM modules, a shock circuit and camera that are interfaced with Raspberry Pi board and Arduino. Women facing any troubles or in any kind of danger, can immediately make use of this device, embedded in their shoe to escape from the dangerous situation and even harm the attacker. The main disadvantages are Complex circuitry and increase in risk due to delayed response time. This model uses an electric teaser, which proves to be harmful to the wearer themselves, as there is a risk of electrocution. The time delay also deters the efficiency and provides the chance of the attacker escaping so we need a device which responds quickly and helps us during the crisis.

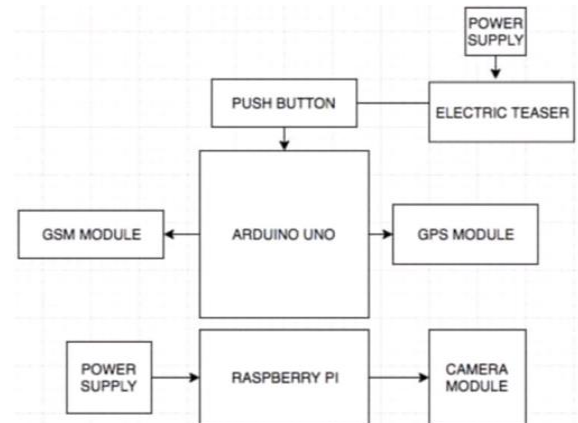

Fig.3.Block diagram of previous work

IV. PROPOSED METHOD

During the time of crisis women will tap the shoe and the piezoelectric plate used here will sense that vibration which is given to the amplifier circuit that amplifies the vibration signal from mV to Volt and provides it to the Wi-Fi module and this signal is transmitted to the android phone of women.

From the mobile the information about harassment and respective location is sent to the Police station and necessary persons via Email, call and SMS. Simultaneously sprayer will release the anesthetic gas which will be turned on and off using relay. The motor driver drives the DC motor, which in turn propels the lever that spontaneously pushes forth for the sprayer to spray its content.

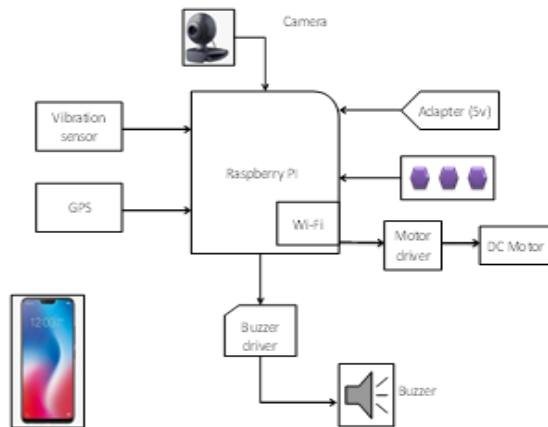

Fig.4. Block diagram of proposed method

HARDWARE COMPONENTS

A. Analog to digital converter module:

ADC can be used to convert both analog and digital signals. When converting analog signals, the I/O pin should be configured for analog by setting the associated TRIS and ANSEL bits.

B. Piezo electric plate:

Piezoelectric Effect is the ability of certain materials to generate an electric charge in response to applied mechanical stress. The piezoelectric plate is a device that uses the piezoelectric effect to measure pressure, acceleration, strain or force by converting them to an electrical charge.

C. Buzzer:

Typical uses of buzzers and beepers include alarm devices, timers, and confirmation of user input such as a mouse click or keystroke. The buzzer is an integrated structure of electronic transducers.

D. DC Motor:

The electric motor is a device which converts electrical energy to mechanical energy. L293D is a typical Motor driver or Motor Driver IC which allows DC motor to drive on either direction. The principle of working of a DC motor is that "whenever a current-carrying conductor is placed in a magnetic field, it experiences a mechanical force".

E. Global positioning system (GPS):

The Global Positioning System (GPS) is a satellite-based navigation system that can be used to locate positions anywhere on earth. Designed and operated by the U.S. Department of Defense, it consists of satellites, control and monitor stations, and receivers. GPS receivers take information transmitted from the satellites and use triangulation to calculate a user's exact location.

The three segments of GPS are space, control, and user.

SOFTWARE PROFILE:

A. CCS Compiler:

A compiler is a computer program that transforms source code written in a programming language into another computer language. This integrated C development environment gives developers the capability to quickly produce very efficient code. Discrete I/O is handled by describing the port characteristics in a PROGRAM. Functions such as INPUT and OUTPUT_HIGH will properly maintain the tri-state registers.

CCS C Compiler Features: Built-in libraries that work with all chips for the RS232 serial I/O, I2C, discrete I/O, and precision delays. Integrates with MPLAB IDE and other simulators and editors for source-level debugging. Standard HEX file and debug files ensure compatibility with all programmers. Efficient function implementation allows call trees deeper than the hardware stack. Assembly code may be inserted anywhere in the source and may reference C variables. Automatic linking handles multiple code pages. Inline functions supported to save stack space; Linker will

automatically determine the best architecture or it can be manually specified.

B. Proteus 7.0 Simulation Tool:

Proteus 7.0 is a Virtual System Modeling (VSM) that combines circuit simulation, animated components, and microprocessor models to co-simulate the complete microcontroller based designs. This is the perfect tool for engineers to test their microcontroller designs before constructing a physical prototype in real-time. Proteus 7.0 is the program to use when we want to simulate the interaction between software running on a microcontroller and any analog or digital electronic device connected to it.

C. Open CV:

Intel Open Source Computer Vision Library. It is a collection of C functions and a few C++ classes that implement some popular Image Processing and Computer Vision algorithms.

Better document Open CV- Details about function calling conventions and how to use them correctly.

Rapidly give the reader an intuitive understanding of how the vision algorithms work. It gives a sense of what algorithm to use and when to use. Takes advantage of high-speed implementations of functions commonly used in Computer Vision/Image Processing.

Key features: Cross-Platform API of C functions FREE for commercial and non-commercial uses.

Open CV Modules:

CV: Main Open CV functions, Image processing, and vision algorithms.

CVAUX: Auxiliary (experimental) Open CV functions.

CXCORE: Data structures, linear algebra support, XML support, drawing functions, and other algorithms.

HIGH GUI: GUI functions, Image, and Video I/O.

D. Embedded C:

Embedded C is a set of language extensions for the C programming language by the C Standards Committee to address commonality issues that exist between C extensions for different embedded systems. Embedded C uses most of the syntax and semantics of standard C, e.g., main () function, variable definition, data type declaration, conditional statements (if, switch case), loops (while, for),

functions, arrays and strings, structures and union, bit operations, macros, etc.

Programming Embedded Systems: Embedded Software or Program allows Hardware to monitor external events (Inputs) and control external devices (Outputs) accordingly. During this process, the program for an Embedded System may have to directly manipulate the internal architecture of the Embedded Hardware (usually the processor) such as Timers, Serial Communications Interface, Interrupt Handling, and I/O Ports, etc.

Factors: Size, Speed, Portability, Ease of Implementation, Ease of Maintenance, Readability. The extension in Embedded C from standard C Programming Language includes I/O Hardware Addressing, fixed-point arithmetic operations, accessing address spaces, etc.

V. RESULT

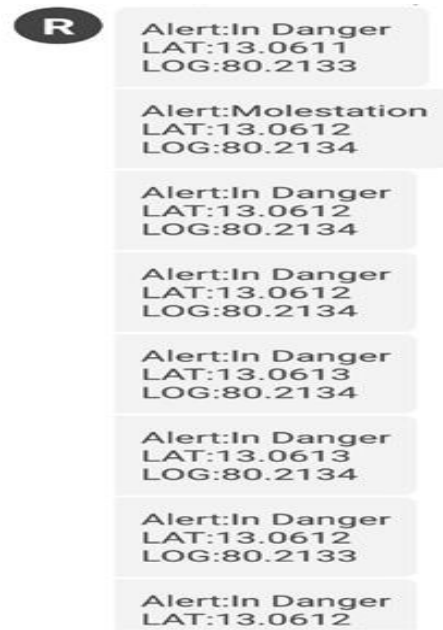

Fig.5.Alert messages received

The wearer taps the piezoelectric plate or the keypad attached with the device, during the times of emergency. As when the vibration signal is sensed which is thereafter amplified. The amplified signal is transferred to the mobile device via wifi and an immediate buzzer alert is produced and a string of emergency panic messages (Alert messages received) are sent to the emergency contacts of the wearer and video call (Video calls received) is also made.

Simultaneously the anesthetic spray goes off rendering the offender's attack



Fig.6.Video calls received

VI. CONCLUSION

Nowadays security is very important aspect for everyone, mostly for women who are facing various harassment problems. This system presents designing about the critical issues faced by women at present days and will help to solve them technologically with compact equipment and ideas. This system can overcome the fear that scares every woman in the country about her safety and security.

Future work: The working prototype used here can be implemented in a shoe, which will prove to be more convenient and effective in our day to day lives.

REFERENCES

[1] "Smart girls security system"- Prof. Basavaraj Chougula, Archana Naik, Monika Monu, Priya Patil and Priyanka Das, International Journal of Application or Innovation in Engineering & Management (IJAIEM) ISSN: 2319-4847 Volume 3, Issue 4, April 2014.

[2] "Self defence system for women with location tracking and SMS alerting through GSM network"- B.Vijaylashmi, Renuka.S, Pooja Chennur, Sharangowda, Patil International Journal of Research in Engineering and Technology (IJRET) eISSN: 2319-1163 pISSN: 2321-7308 Volume: 04 Special Issue: 05.

[3] G.Masario, M.Torchiano and M.Violante, "An in-vehicle infotainment software architecture Based on Google Android", IEEE International Symposium on Industrial Embedded Systems 2009, 8-10 July 2009, pp. 257-260.

[4] Dr. Aditi Jain and Ms. Shivani Gambhir. Socio- "Economic Women Empowerment: Sharp Focus", International Journal of Advanced Research in management, 6(1), 2016, pp. 38-49.

[5] D.Shanthi Revathi and Dr. Jayasree Krishnan. "Problems and Opportunities of Women Entrepreneurs Faced in the Globalized Economy", International Journal of management, 3(1), 2012, pp. 77-81.

[6] Ashlesha Wankhede, Ashwini velankar, Priyanka Shinde "PORTABLE DEVICE FOR WOMEN SECURITY". IJRET, eISSN: 2319-1163p ISSN: 2321-7308

[7] Daniel Clement, Kush Trivedi, Saloni Agarwal, Shikha Singh "AVR Microcontroller Based Wearable Jacket for Women Safety". IRJET, e-ISSN: 2395-0056, p-ISSN: 2395- 0072, Volume03, Issue 05|May 2016.

[8] Dr. Sridhar Mandapati, Sravya Pamidi, Sriharitha Ambati "A Mobile Based Women Safety Application(I Safe Apps)", IOSR-JCE, eISSN: 2278-0661, p-ISSN: 2278-8727, Volume 17, Issue 1, VerI(Jan Feb.2015), PP 29-34.

[9] B. Vijaylakshmi, Renuka S, Pooja Chennur, Sharan gowda, Patil, "SELF DEFENSE SYSTEM FOR WOMEN SAFETY WITH LOCATION TRACKING AND SMS ALERTING THROUGH GSM NETWORK". IJRET, eISSN: 2319-1163, pISSN: 2321-7308.

[10] J Nagraju, V Sadanandam "Self Salvation- The Women's Security Module", IJIREC, Volume 3, Issue 1, January 2016, PP 13-19, ISSN 2349-4042 and ISSN 2349-4050.

AUTHORS PROFILE

1. Dr. Sharmila Durai is an Associate Professor in the Department of Electronics and Communication Engineering at R.M.D Engineering College. She is the Coordinator for Automotive Electronics Centre of Excellence. Her areas of Interest include Microprocessor, Networks and VLSI.
2. Sharmikha Varsha S is a final year student in the Department of Electronics and Communication Engineering at R.M.D Engineering College. Her area of interest includes Networks, Robotics and Automation.

3. Swetha V is a final year student in the Department of Electronics and Communication Engineering at R.M.D Engineering College. Her area of Interest includes Digital Electronics, Computer Networks.
4. Yogasree Nagaraj is a final year student in the Department of Electronics and Communication Engineering at R.M.D Engineering College. Her area of interest includes Computer Networks and Internet of Things.