

High Speed LIFI Based Data Communication in Vehicular Networks

Ms.Pravina.V.A M.E¹, Sahaya shajini J², Sri Ramya V B³, Valarmathi E⁴

¹ Assistant Professor, Department of ECE, DMI College of Engineering, Tamilnadu 600123

^{2,3,4} UG Students, Department of ECE, DMI College of Engineering, Tamilnadu 600123

Abstract - This paper presents the latest technology called as LI-FI which has been developing a lot in few years. Using the concept of LI-FI two vehicle are communicated with the help of LEDs bulbs with the help of transmitter and receiver circuit. With the help of this technology the road accident can be controlled and many human life can be saved. A very chip device called as ultrasonic sensor which is used to measure the distance is used here just to communicate the two vehicles when they come in the contact in some range which is preferred for the ultrasonic sensor. Using this LI-FI the data are transmitted from one vehicle to another. The data that is transmitted through LIFI can be any data like audio, video, or text. This technology was introduced few years back, which needs more systematic enquiry on its sustainability for traffic control purpose. This concept can be implemented at very low cost and with higher efficiency. At present, the day-to-day activities use lot of LEDs based lights for illumination, which can also be used for communication because of the advantages like fast switching, high power efficiency and safe to human vision. Hence, this project presents about ecofriendly data communication between vehicle to vehicle through visible light which consists of the white LEDs that transmit audio signals to the receiver. The receiver circuit consists of solar panel connected with the amplifier and speakers to recover back the amplified version of original input signal. VLC has a bright future, and it acts as a complement to the present RF communication by achieving higher efficiency.

Index Terms - Intelligent Transport System, Light Emitting Diode, Visible light communication, Photodiode, Vehicle-to-Vehicle communication.

I.INTRODUCTION

There are around 1.4 million cell pole radio waves base stations set, with more than 5 billion cell phones. Cell phones transmit over 600TB of information on a normal reason for consistently. Presently a days

remote correspondence utilize radio waves. Yet, radio waves have an issue of effectiveness, accessibility, security and limit. Range is significant necessity for remote correspondence. With headway in innovation and increment in number of clients, existing radio wave range neglects to address the issue and consequently, the limit issue. To determine all the issues, we have concocted the idea of transmitting information remotely through light utilizing LEDs, called as Li-Fi which is a most recent innovation that utilizes LED lights which helps in the transmission of information considerably more quicker, and adaptable due to the sturdiness, effectiveness and high life time attributes that makes Li-Fi idea a superior one. Driven lights are these days generally utilized for individual and authority purposes for their radiant viability improvement. Obvious light correspondence (VLC) is another method for remote correspondence utilizing noticeable light. Common transmitters utilized for noticeable light correspondence are obvious light LEDs and recipients are photodiodes and picture sensors. Being a profoundly populated nation like India and parcel of traffic issues, there is constantly an issue of manual traffic control at whatever point an emergency vehicle shows up along a specific course which is not powerful. The proposed system aims in using lifi for transmission of data through led light between two vehicles which helps in reducing road accident and promotes safe driving.

Dictated short range (1000 meters) communication (DSRC) for Intelligent Transportation Systems (ITS) has opened the door to hundreds of projects and applications of vehicle-to-vehicle communication around the world. In 1999 the US federal communication commission reserved licensed bandwidth of 75 MHz spectrum around 5.9 GHz that allows information to be exchanged among vehicles regardless of their brand [4]. This spectrum will

provide very high data rates with low latency and high security [1] in matter of supporting this wireless communication between vehicles, set of standards were needed to ensure that vehicles understand each other, for example, IEEE 802.11p-2010 standard of wireless link for V2V communications and IEEE P1609.x/D5.8 protocols for information exchange across the wireless link [2].

Vehicular Ad-hoc network (VANET) technology was introduced in 2000 as a specified application of mobile ad hoc networks (MANETs). This network uses vehicles in the road as a router or node in order to communicate at a distance of 100-300 m using several protocols. The networks basically rely on Wi-Fi, WI-Max and DSRC technologies in addition to 3G networks [1]-[2].

Husain Fidvi et. al [3] have proposed vehicle to vehicle communication system that does not require a tracking global positioning System or even a Wi-Fi or 3G wireless connectivity. It was proposed to use Programmable Interface Controller (PIC) sonar which sends 40 KHz short pulse of sound that is undetectable by human ear. The echo of the signal will be detected by microcontroller. The distance is calculated by the time required for echo signal to be transmitted and received [3]. This technology is demonstrated in the figure below.

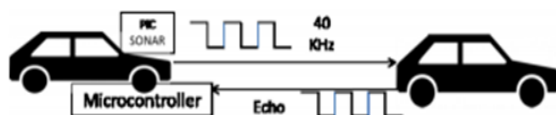

Fig. 1 Communication between Vehicles Using Sonar Pulse

Several research works have been attempted in literature for vehicle-to-vehicle communication using an advantage of light. As light frequency spectrum is huge, it is beneficial to be adopted in a short-range wireless communication [5]-[9]. In this work, we aim to develop a cost effective yet inexpensive mechanism for vehicle-to-vehicle communication through the use of an optical wireless communication medium, which is light. The rest of the paper is organized as follows. Section II explains the details of the proposed system design. In section III, the system diagram is explained. Section IV provides details about the results of the system. Finally, a brief conclusion of the findings is summarized.

II.RELATED WORK

A. Li-Fi: An Infallible Standard for Future Indoor Communication, Abrar I. Soudgar, Aditya U. Kulkarni, Prof. A. R. Surve, Walchand College of Engineering, Opp. Willingdon P.O, Vishrambagh, Sangli, Maharashtra India.

Li-Fi or Light Fidelity is a concept more often considered related to WiFi which is Wireless Fidelity but is far more dissimilar right from the core concept. Li-Fi as opposed to Radio waves in Wi-Fi uses Visible Light for bringing about the communication between two devices. This paper throws light on how Light (VLC) a feasible solution to the existing problems of radio waves with some useful insights on Li-Fi is and how it can improve indoor data transfers and communication. The whole concept originated with the advent of the VLC i.e Visible Light Communication. The idea here is to think out of the radio bandwidth which we are so used to, that we actually use it in 99% of all our wireless communication, but the scenario is changing as Radio waves have some disadvantages like interference, low bandwidth etc. that need a thoughtful update or entire replacement, if need be, this is where the VLC comes in for the rescue. If we look at the electromagnetic spectrum, we can see how small the bandwidth of Radio waves is and that there are still wide range of frequencies that we can use, in this case the Visible Light which falls between the ranges 350nm – 750nm wavelength. Li-Fi uses this band of frequencies for bringing about the communication between two devices. Hence Li-Fi can effectively share the burden on current.

B.Method for calculating the energy loss of a light signal in a telecommunication Li-Fi system, O. I. Romanov, Y. S. Hordashnyk, T. T. Dong, National Technical University of Ukraine “Igor Sikorsky, Kyiv Polytechnic Institute”, Kiev, Ukraine.

One of the possible ways to increase the bandwidth and quality of service for wireless access systems is the use of Li-Fi (Light Fidelity) technology, where instead of radio frequencies, the VLC (Visible Light Communication) spectrum is used for data transmission. In 2011, the IEEE 802.15.7 standard was adopted, which contains recommendations for the provision of PHY and MAC services for Li-Fi visible light networks in private VPAN networks (VLC Personal Area Networks). The article considers the main recommendations for building devices based on

Li-Fi technology, analysis the processes of information exchange between the receiver and the transmitter at the physical level (PHY) and considers parameters that affect the communication range and methods for determining them. A method is proposed for calculating the energy attenuation of light-emitting diodes in light paths when wireless access is arranged in a standard office room.

C. Li-Fi technology in traffic light, V.K.G. Kalaiselvi, A. Sangavi, Department of Information Technology, Sri Sairam Engineering College, India, Dhivya, Department of Computer Science, India.

Wireless communication has become a basic utility in personal and business life such that it becomes a fundamental of our lives and these 8 communications uses the radio spectrum for data transfer. There are issues in using the radio spectrum further, they are, capacity, efficiency, availability, and security. The defects of Wi-Fi technology have given birth to the concept of Li-Fi (Light Fidelity) technology. Li-Fi can be defined as a light-based Wi-Fi. This technology mainly serves the purpose of transmitting data using retrofitting of LED Bulbs that has high efficiency, durability, and reliability. This technology emerged by 1990s in a lot of countries like Japan, German, and Korea. The proposed paper aims in using the Wi-Fi technology and enabling communication of vehicles with the traffic light system in order to prioritize the vehicles and change the signals accordingly rather than by a process of predefined order or by manual order. Traffic lights already use LED lighting, so that this proposed system may seem easy to implement. Sending data through siren lights in an ambulance and fire extinguishers to a traffic light control system and switching the signal in order to allow faster and non-interrupted transport. Here is already a kind of system in play for GPS navigational systems, but the traffic lights can be used in updating drivers using basic information or streaming video directly from news broadcasts i.e., about the accidents or delays up ahead.

D. Low-Latency and High-Reliability Cooperative WSN for Indoor Industrial Monitoring, Zafar Iqbal, Heung-No Lee, Sch. Of Electronic. Eng. & Computer Sci., Gwangju Inst. Of Sci. & Technol., Gwangju, South Korea.

Sensor networks have been widely used traditionally in monitoring the state of heavy machinery and large

factories whose condition is critical to the operation of machine as well as the safety of people around them. Recently, industrial wireless sensor networks (IWSNs) are getting popular 9 for environment monitoring in such conditions to help us make a decision on the state of machines in a certain area of interest. However, the wireless communication channels, which these sensors must operate in, are not always reliable, and observations of some sensors cannot be reported successfully to the base station. In order to deal with this problem, we propose a dual-hop cooperative WSN scheme, which uses in-network data aggregation mechanism in order to reduce the overall latency as well as improve the reliability of the received information. We also devise a protocol for the organization and operation of the proposed sensor network. The proposed scheme effectively increases the probability of correct decision about the state of the machines and reduces the probability of false alarms at a given signal level.

III. BLOCK DIAGRAM

The propose plan of action for our project is inter-vehicles communication using optical wireless model having high data rates (in the range of MHz to GHz) and transmission distances is near about 1m. For transmission of information from one device to another device requires LED. In this system at the transmitter section input data given using switching control system. According to the data, the microcontroller generates a stream of 1s and 0s thereby translate the data in binary. The output of this controller is given to the LEDs which is connected to transmitter side.

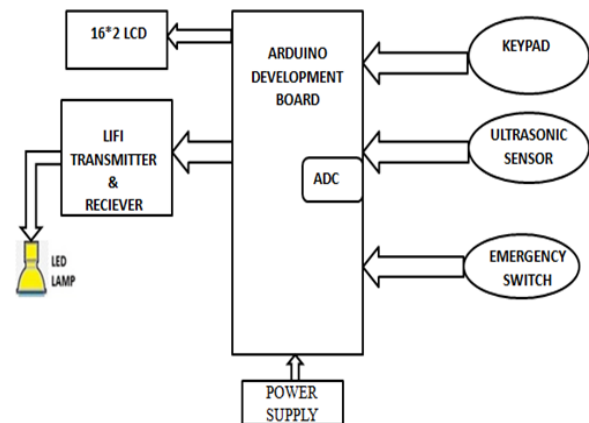

Fig 2: Transmitter Unit

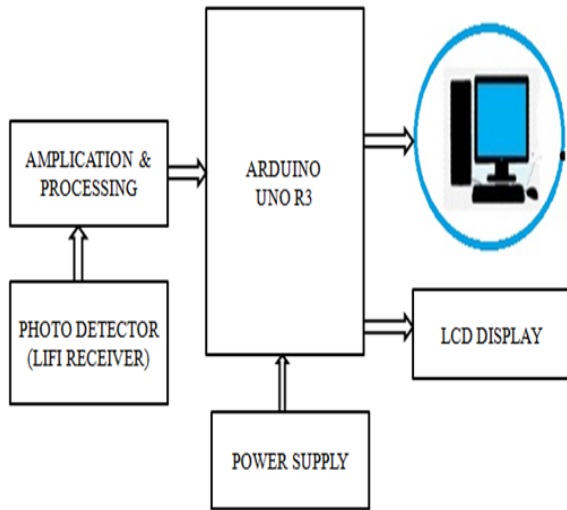

Fig 3: Receiver Unit

A. Hardware Requirements

- Arduino Uno R3
- Lifi Transmitter & Receiver
- Keypad
- Audio Module
- Lcd Display
- Regulated Power Supply
- Switch

B. Software Requirement

- ARDUINO IDE
- Embedded C

IV. HARDWARE IMPLEMENTATION

A. Arduino UNO

The Arduino UNO is an open-source microcontroller board based on the Microchip ATmega328P microcontroller and developed by arduino. The board is equipped with sets of digital and analog input/output (I/O) pins that may be interfaced to various expansion boards (shields) and other circuits. The board has 14 Digital pins, 6 Analog pins, and programmable with the Arduino IDE (Integrated Development Environment) via a type B USB cable. It can be powered by a USB cable or by an external 9-volt battery, though it accepts voltages between 7 and 20 volts. It is also similar to the Arduino Nano and Leonardo. The hardware reference design is distributed under Common Creative Attribution Share-Alike 2.5 license and is available on the arduino website. Layout and production files for some versions

of the hardware are also available. "UNO" means one in Italian and was chosen to mark the release of Arduino Software (IDE) 1.0. The UNO board and version 1.0 of arduino Software (IDE) were the reference versions of arduino, now evolved to newer releases. The UNO board is the first in a series of USB arduino boards, and the reference model for the arduino platform. The ATmega328P on the arduino UNO comes preprogrammed with a boot loader that allows uploading new code to it without the use of an external hardware programmer. It communicates using the original STK500 protocol. The UNO also differs from all preceding boards in that it does not use the FTDI USB-to serial driver chip. Instead, it uses the Atmega16U (Atmega8U2 up to version R2) programmed as a USB-to-serial converter.



Fig -4: Arduino Board

B. LCD

Liquid Crystal Display (LCD) is used to display the output to the user in the form of GUI (Graphic User Interface) and a mono chromatic display. LCD used in this project is JHD162A series. There are 16 pins in all. They are numbered from left to right 1 to 16 (if you are reading from the backside). Generating custom characters on LCD is not very hard. It requires the knowledge about custom generated random-access memory (CG-RAM) of LCD and the LCD chip controller. Most LCDs contain Hitachi HD4478 controller. CG-RAM is the main component in making custom characters. It stores the custom characters once declared in the code. CG-RAM size is 64 byte providing the option of creating eight characters at a time. Each character is eight byte in size.

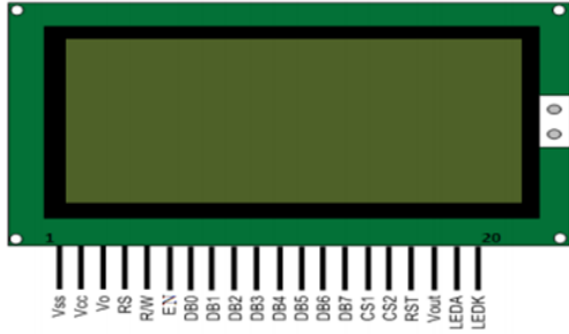

Fig 5: LCD

C. Ultrasonic sensor

Ultrasonic sensor is the device which is used to measure the distance. The working principle of the ultrasonic sensor is that it uses high intensity of sound waves, and the sound waves are returned as the echo to the sensor, with the help of this concept the distance are measured. Here in this project ultrasonic sensor are used to measure the distance between the two vehicles when they come nearer to some extent. As the two vehicles comes across in the contact the data is transferred to the other vehicle about the current status of the vehicle so that the chance of accident reduces. The below figure 5 is shown how the ultrasonic sensor is placed on the vehicle.

D. Li-Fi Transmitter

First transmitter will be connected to the Arduino board. Then Arduino board will send the data to transmitter, the transmitter will convert the data into binary and make it ready to transfer the data, now the data will be transferred using LED bulb. If the binary number is 0, then the led will not blink if binary number is 1 the LED will blink. The LED bulb will turn on and off so fast that the human eye cannot see. This is one of the methods to transfer the data using Li- Fi.



Fig 6. Li-Fi Transmitter

E. Li-Fi Receiver

The Photovoltaic cell will receive the light from the LED then the photovoltaic cell will send that to the receiver. The receiver will convert that binary data into actual data then send that data to the arduino board.

V. RESULTS AND DISCUSSION

Li-Fi technology may provide theoretically a speed of up to 10Gbps. Cost effective and more robust and useful than Wi-Fi. Li-Fi is not expected to completely replace Wi-Fi, but the two technologies could be used complementarily to create more efficient, green and future-proof access networks. Li-Fi is a wireless technology that makes use of visible light in place of radio waves to transmit data at terabits per second speeds more than 100 times the speed of Wi-Fi. Li-Fi technology has immense possibilities, from public internet access through streetlamps to auto-piloted cars that communicate through their headlights.

The output of the implemented system is shown in figure 14 above. The blinking of the LED was detectible at frequencies lower than 1 kHz unlike frequencies above 1 kHz which made the LED seems like constantly on. Thus, frequencies higher than 1 kHz must be used in the proposed system. The output voltage of the receiving circuit was about 5 V when the LED was close to the receiver while it decreased as the transmitting distance increased. The output of the system was quite good in terms detecting levels of data as being ON or OFF, although it decreased with the increment of distance, but it was still good enough to be used in processing and applications. The output of the system had some noise since there were no filters used yet in this phase of the project. The system will be improved further to provide better quality of output. A complete prototype will also be implemented and tested in a small-scale vehicle to vehicle communication to investigate effectiveness of the system in the aforementioned scenarios.



Fig 7. Experimental Setup

VI.CONCLUSION

The transmission of data from one vehicle to another is done in a very easier by Li-Fi technology by using led light. Thus, this method will help us to avoid road accidents. In future this data transmission using Li-Fi technology will be promised to play a vital role in human's life. Here in this report, we are going to sort out the problem like speed and jamming in WI-FI by using LI-FI technology. In this paper it is concluded that the possibilities are numerous and can be explored further this technology is in manufacturing process to produce every bulb to become a WiFi hotspot to transmit wireless data But this traffic problem get reduces to a great number by using LI-Fi technology and this will proceed towards the cleaner, greener, safer and brighter future in this world without radio wave, because radio waves create a harmful effect for living thing, but Li-Fi is the optical wireless communication for data, audio and video streaming in LEDs. In future this system helps the communication much easier than other system. It involves Li-Fi communication, we can use this system in places such as Industries, offices etc.

REFERENCES

- [1] Z. Xu and B. Sadler, "Ultraviolet communications: potential and state-of-the-art," *IEEE Communications Magazine*, vol. 46, no. 5, pp. 67-73, Jun. 2008.
- [2] H. Elgala, R. Mesleh, and H. Haas, "Indoor optical wireless communication: potential and state-of-the-art," *IEEE Communications Magazine*, vol. 49, no. 9, pp. 56-62, Sept. 2011.
- [3] G. Pang, T. Kwan, H. Liu, and C. Chan, "Optical wireless based on high brightness visible LEDs," *IEEE Industry Applications Conf.*, vol. 3, pp.1693-1699, Oct. 1999.
- [4] T. Yamazato, M. Kinoshita, S. Arai, E. Souke, T.Yendo, T. Fujii, and H. Okada, "Vehicle motion and pixel illumination modeling for image sensor based visible light communication," *IEEE Journal on Selected Areas in Communications*, vol. 33, no. 9, pp. 1793-1805, Sept. 2015.
- [5] M. Hiruta, M. Nakagawa, S. Haruyama, and S. Ishikawa, "A study on optical wireless train communication system using mobile object tracking technique," *International Conf. on Advanced Communication Technology*, vol. 1, pp. 35-40, Feb. 2009.
- [6] A. Gomez, K. Shi, C. Quintana, G. Faulkner, B. C. Thomsen, and D. O'Brien, "A 50 Gb/s transparent indoor optical wireless communications link with an integrated localization and tracking system," *Journal of Lightwave Technology*, vol.34 no.10, pp. 2510-2517, May. 2016.
- [7] T. Saito, S. Haruyama, and M. Nakagawa, "A new tracking method using image sensor and photo diode for visible light road-to-vehicle communication," *International Conf. on Advanced Communication Technology*, vol.1, pp.673-678, Feb. 2008.
- [8] Z. Lu, P. Tian, H. Chen H, I. Baranowski, H. Fu, X. Huang, J. Montes, F. Youyou, H. Wang, X. Liu, R.Liu, and Y. Zhao, "Active tracking system for visible light communication using a GaN-based micro-LED and NRZOOK," *Optics Express*, vol. 25, no.15, pp. 17971-17981, Jul. 2017.
- [9] L. Song, D. Kotz, R. Jain, and X. He, "Evaluating location predictors with extensive Wi-Fi mobility data," *IEEE INFOCOM*, vol. 2, pp. 1414-1424, Mar. 2004.
- [10] D. Ashbrook and T. Starner, "Using GPS to learn significant locations and predict movement across multiple users," *Personal and Ubiquitous Computing*, vol. 7, no. 5, pp. 275-286, Sept. 2003.
- [11] S. Lee, J. Lim, J. Park, and K. Kim, "Next place prediction based on spatiotemporal pattern mining of mobile device logs," *Sensors*, vol. 16, no. 2, pp. 145, Jan. 2016.
- [12] J. Ying, W. Lee, T. Weng, and V.Tseng, "Semantic trajectory mining for location prediction," *ACM International Conf. on Advances in Geographic Information Systems*, pp. 34-43, Nov. 2011.
- [13] L. Yann, and J. Alliot, "Using neural networks to predict aircraft trajectories," *International Conf. on Artificial Intelligence*, pp. 524-529, May. 1999.
- [14] Y. Matsuno, T. Tsuchiya, J. Wei, I. Hwang, and N. Matayoshi, "Stochastic optimal control for aircraft conflict resolution under wind uncertainty," *Aerospace Science and Technology*, vol.43, pp. 77-88, Jun. 2015.

- [15] E. Cho, S. A. Myers, and J. Leskovec, "Friendship and mobility: user movement in location-based social networks," ACM International Conf. on Knowledge Discovery and Data Mining, pp. 1082-1090, Aug. 2011.
- [16] P. B. Solanki, M. Al-Rubaiai and X. Tan, "Extended kalman filter-based active alignment control for LED optical communication," IEEE/ASME Transactions on Mechatronics, vol. 23, no. 4, pp. 1501-1511, Aug. 2018.
- [17] J. Greenberg, and X. Tan. "Kalman filtering-aided optical localization of mobile robots: system design and experimental validation," ASME Dynamic Systems and Control Conf.. vol.2, Oct. 2017.
- [18] F. Liu, W. Jiang, X. Jin, and Z. Xu, "A simple and effective tracking scheme for visible light communication systems," International Conf. on Optical Communications and Networks, vol. 11048, pp.140481, Nov. 2019.
- [19] M. Agostinacchio, D. Ciampa, and S. Olita, "The vibrations induced by surface irregularities in road pavements—a Matlab® approach," European Transport Research Review, vol. 6, no. 3, pp 267-275, Dec. 2013.
- [20] G. Hakan, "Industrial motion control: motor selection, drives, controller tuning, applications," John Wiley and Sons, pp. 21-45, Sept. 2015.