

Development of Fire Extinguisher Robo

Faheem Haider Haidry¹, Ankita Lakhwani², Nikhil Mandhyani³, Manish Poptani⁴, Om Gajbhiye⁵, Jay Rautel⁶, Amar Kawale⁷

^{1,2,3,4,5,6} Student, Dept. of Mechanical Engineering, Jhulelal Institute of Technology, Nagpur, Maharashtra, India

⁷Guide, Dept. of Mechanical Engineering, Jhulelal Institute of Technology, Nagpur, Maharashtra, India

Abstract - Fire hazard is a very common phenomenon in developing countries, which causes huge loss of lives and properties every year. Lack of detecting fire hazard in initial stage, delay in sending information to fire service authority and failure of taking primary initiative to extinguish or prevent spreading of fire increases the loss. This paper is concerned with developing of a microcontroller based autonomous fire extinguisher robot which is able to detect a fire hazard automatically when it occurs, sends information to fire service authority instantly and takes initiative to extinguish the fire. Three different sensors are used to detect the fire hazard. Microcontroller takes data from sensors and makes a decision of fire hazard analysing the data. At the same time, it runs to search the fire following a black track in the floor and throw water to extinguish the fire by activating a water pump when it gets a flame.

Index Terms - Fire Extinguisher Robo, DC motors, Flame Sensor, Water pump, Arduino, and Human Life.

I. INTRODUCTION

Fire safety has become a major issue in our country is that in the recent few years and is raising critical concerns. It is also a buzzing word in Indian garment factories. Every year we are losing our important life and property. The use of modern technology in fire safety can reduce the enormous loss of fire hazard. That's why researchers are motivated to develop more reliable and intelligent fire detection and fire extinguisher system. A lot of researches have already been done to minimize the fire hazard as well to reduce the demolition in fire hazard.[6]

In this paper, our objective is to build a fire extinguisher robot which can detect fire hazard automatically, inform about the hazard to the nearby fire service authority and takes initiative to stop the spreading of fire. Fire hazard is detected by sensing three parameters: temperature, smoke and flame.

Three different sensors are used to measure these parameters. If temperature or smoke increases above a critical value the robot decides the event as a fire hazard. In this case, robot starts running through a predefined path to search fire by flame sensor. When flame sensor detects a flame, robot start throwing water, foam, gas, or other materials used extinguish a fire.

II. SYSTEM OVERVIEW

The block diagram of the system is shown in “Fig. 1”. Microcontroller takes data from IR receiver transmitter to detect the track and drives two DC motors to follow the track. Temperature, smoke and flame sensor are used to detect fire hazard. Pump is used to spray water or any other chemical components to extinguish fire. Bluetooth module sends data to fire service through an android device and buzzer gives alarm to conscious the people about fire.

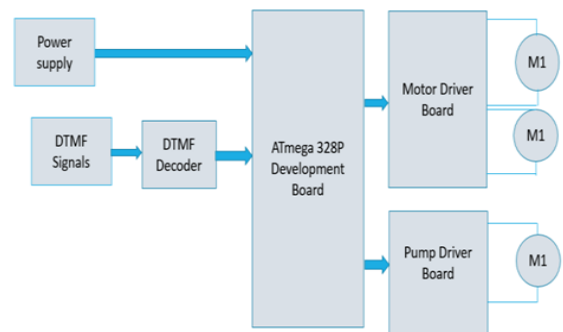

Fig 1: System Block Diagram

III. METHODOLOGY

This section describes the methodology of developing the system. The development process includes data acquisition from different sensors, line following mechanism, sending data via Bluetooth, driving pump and the Arduino UNO Microcontroller board based on

the ATmega328P. The ATmega328P is good platform for robotics application. Thus the real time fire extinguishing can be performed. Finally the complete circuit diagram of the system. Arduino C is derived from C and C++ programming and is much easier when compared other controller programming.

The microcontroller in turn controls the extinguishing system. The Operating Voltage of the controller is 5V and the Clock Speed is 16 MHz, and the recommended Input Voltage 7-12V, whereas the limitation of Input Voltage between 6-20V. The Dual-tone multi-frequency signaling (DTMF) is an in-band telecommunication signaling system which use the voice-frequency band over telephone lines between telephone equipment and other communications devices and switching centres. Here, the IC MT8870DE, a touch tone decoder IC is used. The main aim of this project is to develop a DTMF controlled fire extinguishing robot which detects the fire location and extinguish fire by using sprinklers on triggering the pump. The direction of movement of the robot is described by the motor driver board. It is used to give high voltage and high current is given as an output to run the motors which are used in the project for the movement of the robot. In this project a simple DC motor is used for the rotation of the wheel which is responsible for the movement of the robot. DC motors usually convert electrical energy into mechanical energy. To extinguish the fire a pump is used to pump the water on to the flame. A simple motor is used to pump the water. The pumping motor in extinguishing system controls the flow of water coming out of pumping.

IV. HARDWARE & SOFTWARE DETAILS

HARDWARE USED:

1. ATmega328P microcontroller (Arduino UNO):

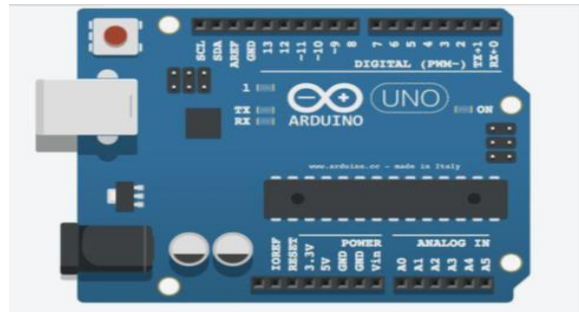

Fig 2: Arduino Uno microcontroller-based development board

Fig 2 shows the arduino Uno board. Arduino/Genuino Uno is a microcontroller board based on the ATmega328P. It has 14 digital input/output pins (of which 6 can be used as PWM outputs), 6 analog inputs, a 16 MHz quartz crystal, a USB connection, a power jack, an ICSP header and a reset button. It contains everything needed to support the microcontroller.

2. Flame Sensors:



Fig 3: Flame Sensor

Fig 3 shows the flame sensor. This sensor is able to detect a flame by sensing light wavelength between 760 –1100 nanometres. The test distance depends on the flame size and sensitivity settings. The detection angle is 60 degrees, so the flame does not have to be right in front of the sensor.

There are two sensor outputs

- I. Digital – sending either zero for nothing detected or one for a positive detection
- II. Analog – sending values in a range representing the flame probability/size/distance; must be connected to a PWM capable input

3. DTMF Signal and Decoder.

Dual-tone multi-frequency signaling (DTMF) is an in-band telecommunication signaling system using the voice-frequency band over telephone lines between telephone equipment and other communications devices and switching centres. DTMF was first developed in the Bell System in the United States and became known under the trademark Touch-Tone for use in push-button telephones supplied to telephone customers, starting in 1963 we are using the IC MT8870DE which is a touch tone decoder IC.

4. Motor Drivers:

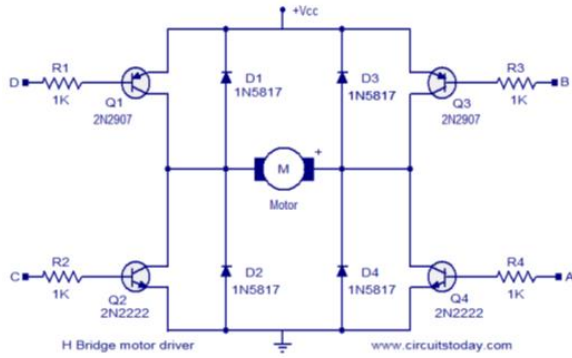

Fig 4: H Bridge circuit

Motor drivers are used to describe the direction of movement of the robot. It is used to give high voltage and high current as an output to run the motors which are used in the project for the movement of the robot. Fig 4 is the circuit of the H Bridge which is used for the motor driving in the IC L293D and also provides the bidirectional motor control.

5. DC Motors:

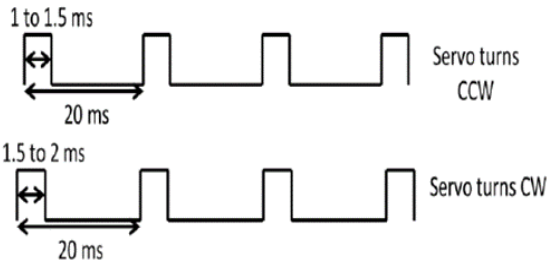

Fig 5: PWM signal provided to servo motor

The servo motor is used to achieve precise angular positioning of water nozzle. A servo motor has three terminals: Vcc, GND and control signal. [7] The control signal is a pulse width modulated (PWM) wave of frequency 50Hz i.e. time period of the PWM wave is 20ms. By changing the width of PWM we can change the angular position of the servo shaft. A pulse of 1 to 1.5ms turns the servo in clockwise (CW) direction, pulses between 1.5ms to 2.0ms makes it to turn counter clockwise (CCW) and a pulse of 1.5ms turns the servo to its centre as shown in “Fig. 5.

6. Pump:

Pump is a mechanical device which is used to pump water on to the fire to extinguish it. It uses a simple motor to pump water.

V- SOFTWARE USED

1. Arduino IDE 1.6.7:

For programming the microcontrollers, the Arduino project provides an integrated development environment (IDE) based on a programming language named Processing, which also supports the languages, C and C++.The open source Arduino IDE makes it easy to write code and upload it to the board.

VI- PROGRAMMING

In this section its represent the programming and practical implementation of our system.

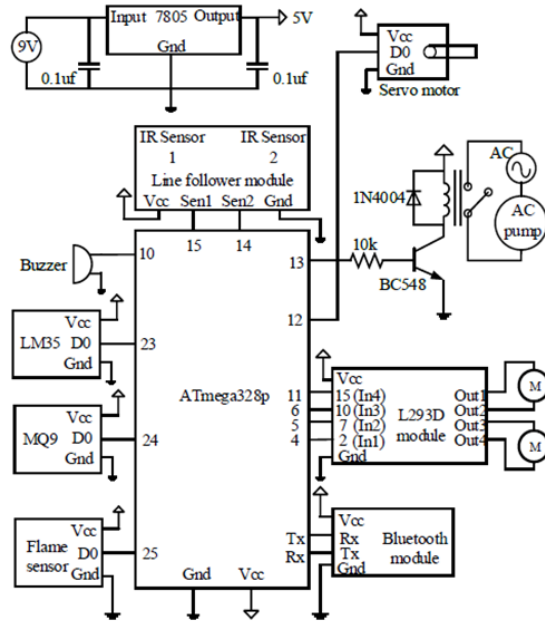

Fig 6: Complete Circuit diagram of the system

VII- CONCLUSION

The Fire Fighting Robot employs DTMF technology to control the directions of the robot. We design the fire detection system using flame sensor that is capable of sensing the flame. Since this robot is built as a prototype it has various limitations. More research should do to improve the current robot. In the present condition it can extinguish fire only in the room where it is placed but that can be solved by placing sensors in different rooms which will alert the robot as soon as it detects fire. The robot will then go there to extinguish the flame. The water carrier can also be replaced by more efficient fire Extinguisher.

VIII- LAYOUT

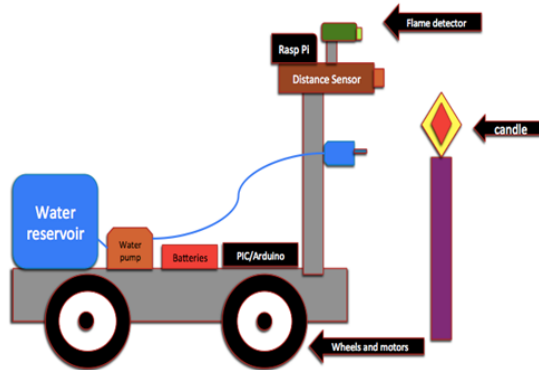

Fig 7: Layout Diagram

REFERENCES

- [1] Control of an Autonomous Industrial Fire Fighting Mobile Robot by HP SINGH, Department of Mathematics, Sri Venkateswara College, University of Delhi
- [2] A System Architecture of Wireless Communication for Fire-Fighting Robot by Korea Advanced Institute of Science and Technology (KAIST), 335 Gwahangno, Yuseong-gu, Daejeon 305-701, Republic of Korea
- [3] <https://www.arduino.cc/en/Main/ArduinoBoardUno>
- [4] <http://www.slideshare.net/maastech/robotics-projects-abstractfire-fighting-robot-with>
- [5] Chris Flesher, Devona Williams, Sean Benbrook, Somendra Sreedhar "Fire Protection Robot. Final Report" p. 1-78, 2004.
- [6] Madhavi Pednekar et. al., " Voice operated intelligent fire extinguishing vehicle," in Proc. of International Conference on Technologies for Sustainable Development (ICTSD-2015) , 4-6 Feb. 2015, Mumbai, India.
- [7] "Servo Motor Control", April 7, 2012.