

# Wi-Fi Controlled Intelligent Robot

T. RAKESH<sup>1</sup>, T. SUJITH<sup>2</sup>, B. AAKASH<sup>3</sup>, B SHRAVAN KUMAR<sup>4</sup>

<sup>1, 2, 3</sup> Student, J B Institute of Engineering and technology (JBIET), Hyderabad

<sup>4</sup> Assistant professor, J B Institute of Engineering and technology (JBIET), Hyderabad

**Abstract—** *This project's main functionality is to deal with tough situations where human beings cannot handle situations like darkness, entering narrow and small places and detecting hidden bombs etc. Such hostile situation is occurring day by day in different parts of the world through terrorist attack or in natural catastrophes. This designed system is connected to a remote computer wirelessly through which the whole controlling of the system response is done. This project deals with the design and implementation of Wi-Fi controlled Intelligent robot using Raspberry pi. It uses wireless technology to provide essential security using surveillance system. The proposed security system captures information and transmits it via a WiFi to a static IP, which is viewed using a web browser from any smart device. Raspberry pi controls a video camera for surveillance. It streams live video and records the motion detected parts in the cloud and/or in the windows shared folder for future playback. The cameras automatically initiate recording when motion is sensed and the Raspberry pi device stores it in a secured folder.*

## I. INTRODUCTION

A robot is generally an electro-mechanical machine that can perform tasks automatically. The surveillance system is one which is used for the purpose of security system in intrude areas. Robots can be classified into different types based on their environment and mechanism of interaction such as mobile and fixed robot of which mobile robot can be further classified as aquatic, terrestrial and airborne. The terrestrial robots are much in use and their applications are vast in each and every field, they are of two types (i) wheeled and (ii) legged each having a different use.

Robots are being used in variety of industrial applications for various activities like pick place, painting, assembling of subsystems and in hazardous

places for material handling etc. Nowadays robots in the use of surveillance is emerging because of their miniature size allowing them to enter in tunnels, mines and small holes in building and also have capability to survive in harsh and difficult climatic conditions for life long time without any defect and causing no harm. This project's main functionality is to deal with tough situations where human beings cannot handle situations like darkness, entering narrow and small places and detecting hidden bombs etc. Such hostile situation is occurring day by day in different parts of the world through terrorist attack or in natural catastrophes. This designed system is connected to a remote computer wirelessly through which the whole controlling of the system response is done. The project is also designed to search invisible metal stuffs from where people are not capable to reach and it is so designed to work in environment where visible light will not be available.

The proposed system consist of two units mainly a robotic unit and a remotely control unit. The robotic unit is consisting of the webcam, sensors and the heart of the project, raspberry pi along with the PCB containing motor driven IC and voltage regulator circuitry. The rest of the paper is organized as follows: we review the related works in Section II. Section III presents about the surveillance robot in detail. Section IV, presents the conclusion and future work of the paper.

## II. RELATED WORKS

### A. Review Stage

Service robots assist human beings, typically by performing a job that is dirty, dull, distant dangerous or repetitive, including household chores. They typically are autonomous and/or operated by a built-in control system, with manual override options. The International Organization for Standardization defines a "service robot" as a robot "that performs useful tasks

for humans or equipment excluding industrial automation applications”. The surveillance robot that is used in defense comes under the service robot that does the dangerous job. These robots are usually unmanned and are operated by a remote desktop generally, there are three kinds of unmanned machines used in the military operations:

- Unmanned Ground Vehicle (UGV): They are used for ground purposes. They can carry heavy load, move on uneven terrains and have various sensors and cameras fitted on them.
- Unmanned Aerial Vehicle (UAV): They are used to carry aerial weapons and flying machines.
- Unmanned Underwater Vehicle (UUV): They are submarines or machines, which can survey under water.

These unmanned robots are equipped with the necessary sensors and the motor system and they are provided with a wireless cameras will send back real time video and audio inputs that can be seen on a remote monitor in the base station from where the robot is being controlled. These are widely used in battle field.

### III. SURVEILLANCE ROBOT PROBLEM DEFINITION

The surveillance robot is designed to be multitasking, cost efficient and feasible machine that can be implemented for the military purpose. These machines replaces the Indian army soldiers and dogs that are used at the borders during the time of war saving the lives from opponents or enemy nations and from environmental condition such as extreme cold and heat.

These system consists of two units mainly a robotic unit and a remotely control unit. The Robotic unit consists of a microcontroller, the microcontroller here is the raspberry pi forming the central control of the system which is connected to a remote network wirelessly and is controlled by a remote user. The system is driven by a motor and the power supply is provided by a 12v battery. The system is equipped by different sensor each of different use the IR sensor is used to sense the presence of obstacles and it automatically redirects its way in the obstacles, the PIR sensor detects the presence of living objects in and

around all these are captured by a pi vision camera, the system has metal detecting sensor which detects the presence of any metal things underground angives an alert indicating the presence of the metal and can be viewed on the monitor screen this forms the hardware part of the system .

The software part is the web application which displays the status of the IR, PIR and metal detecting sensor and the images captured by the pi camera is displayed on the screen on the webpage. The web application has a added advantage of storing the images captured and gives the detailed history of the pictures captured before.

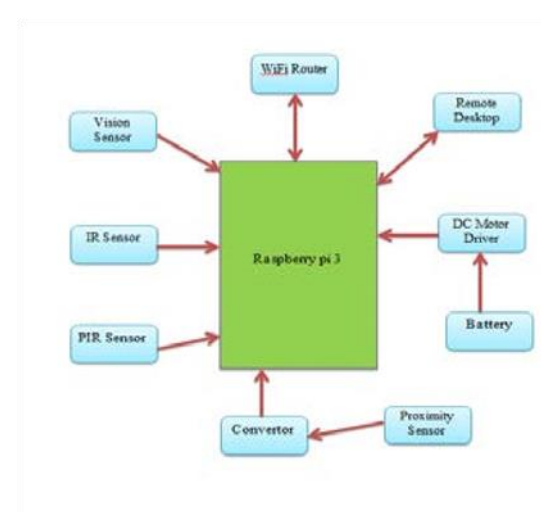

Fig.1. Block diagram of the entire system

### 3.1 SYSTEM DESIGN AND MODULE DESCRIPTION

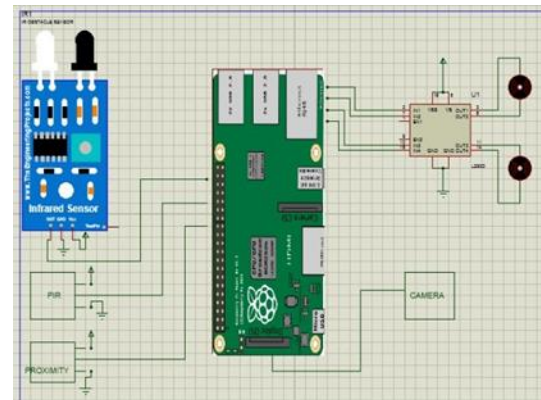

Fig 2. system design

The above figure describes the connections is the system where the raspberry pi takes the central control

and is connected to all the sensors, camera, motor and power supply. The system can be divided into four modules which are listed below

**SENSOR MODULE**

**PIR SENSOR**

This sensor is used to detect the movement of human beings in and around it. This emits the radiation and detects the heat and temperature of the body and finds the object before it

**IR SENSOR**

This sensor is also used to detect the obstacles coming on the both sides of the device and detects the motion of the object. It does not emit the radiation but it measures the radiation of the object before it.

**PROXIMITY SENSOR**

This sensor is used to detect the metal objects around it without having any Physical contact with them and it emits the electromagnetic radiation and detects the objects

**CAMERA INTERFACE MODULE PI CAMERA**

This vision sensor PI camera is used to capture the images and motions of the object before it and this is set on the top of the system and it can be moved in and around to capture the images in different locations and it sends those recordings to the web server for later purpose.

**RASPBERRY PI**

This Raspberry pi board is used as an interface between the software and hardware and this has an inbuilt wireless controller and also a Bluetooth controller which supports the PI camera and connects all the sensors with the system hardware.

**3.2 SYSTEM HARDWARE**

*A. Raspberry pi 3*



Fig.3. Raspberry pi 3

The Raspberry Pi 3 Model B is the third generation Raspberry Pi. This powerful credit card sized single board computer can be used for many applications and supersedes the original Raspberry Pi Model B+ and Raspberry Pi 2 Model B. Whilst maintaining the popular board format the Raspberry Pi 3 Model B brings you a more powerful processor, 10x faster than the first generation Raspberry Pi. Additionally it adds wireless LAN & Bluetooth connectivity making it the ideal solution for powerful connected designs. With its built-in wireless connectivity, the new Raspberry Pi is clearly positioned as a low-cost hub for Internet of Things devices, or as the flexible, low-cost basis of new types of connected gadgets. The new bump to a 2.5 amps power source means it will be able to power more complex USB devices without the need for a second power cable.

*B. Infrared Sensor*

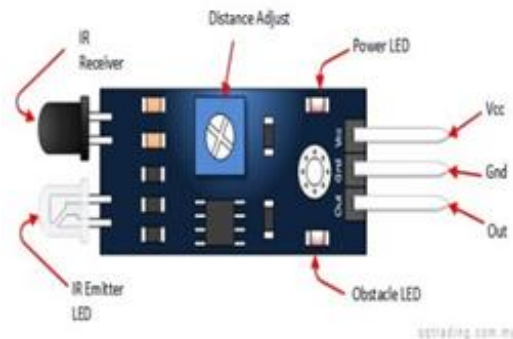

Fig.4. Infrared Sensor

Infrared Obstacle Avoidance Proximity Sensors Module has built-in IR transmitter and IR receiver that sends out IR energy and looks for reflected IR energy to detect presence of any obstacle in front of the sensor module. The module has on board potentiometer that lets user adjust detection range. The sensor has very good and stable response even in ambient light or in complete darkness. The sensor module can be interfaced with Arduino, Raspberry Pi or any microcontroller having IO voltage level of 3.3V to 5V.

*C. PIR Sensor*

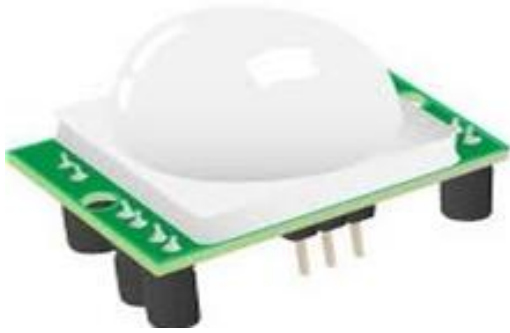

Fig 5. PIR Sensor

PIR sensor detects a human being moving around within approximately 10m from the sensor. This is an average value, as the actual detection range is between 5m and 12m. PIR are fundamentally made of a pyro electric sensor, which can detect levels of infrared radiation. For numerous essential projects or items that need to discover when an individual has left or entered the area. PIR sensors are incredible, they are flat control and minimal effort, have a wide lens range, and are simple to interface with.

PIR acts as a digital output so all you need to do is listening for the pin to flip high or low. The motion can be detected by checking for a high signal on a single I/O pin. Once the sensor warms up the output will remain low until there is motion, at which time the output will swing high for a couple of seconds, then return low. If motion continues the output will cycle in this manner until the sensors line of sight of still again. The PIR sensor needs a warm-up time with a specific end goal to capacity fittingly. This is because of the settling time included in studying nature's domain. This could be anyplace from 10-60 seconds

*D. Proximity Sensor*

A proximity sensor is a sensor able to detect the presence of nearby objects without any physical contact. A proximity sensor often emits an electromagnetic field or a beam of electromagnetic radiation (infrared, for instance), and looks for changes in the field or return signal. The object being sensed is often referred to as the proximity sensor's target.



Fig 6. Proximity Sensor

Different proximity sensor targets demand different sensors. For example, a capacitive proximity sensor or photoelectric sensor might be suitable for a plastic target; an inductive proximity sensor always requires a metal target. Proximity sensors can have a high reliability and long functional life because of the absence of mechanical parts and lack of physical contact between the sensor and the sensed object.

*E. Motor*

500 RPM 12V DC Geared Motor is high-quality low-cost DC geared motor. It has steel gears and pinions to ensure longer life and better wear and tear properties. The gears are fixed on hardened steel spindles polished to a mirror finish. The output shaft rotates in a plastic bushing. The whole assembly is covered with a plastic ring. Gearbox is sealed and lubricated with lithium grease and require no maintenance.



Fig 7. Motor

The motor is screwed to the gear box from inside. Although motor gives 500 RPM at 12V but motor runs smoothly from 4V to 12V and gives wide range of RPM, and torque. 500RPM 12V DC geared motors for

robotics applications. Very easy to use and available in standard size. Nut and threads on shaft to easily connect and internal threaded shaft for easily connecting it to wheel.

#### F. Motor Driver



Fig 8. Motor Driver

L293D is a typical Motor driver or Motor Driver IC which allows DC motor to drive on either direction. L293D is a 16-pin IC which can control a set of two DC motors simultaneously in any direction. It means that you can control two DC motor with a single L293D IC. It works on the concept of H-bridge. H-bridge is a circuit which allows the voltage to be flown in either direction. As you know voltage need to change its direction for being able to rotate the motor in clockwise or anticlockwise direction, Hence H-bridge IC are ideal for driving a DC motor. In a single L293D chip there are two h-Bridge circuit inside the IC which can rotate two dc motor independently. Due its size it is very much used in robotic application for controlling DC motors. Given below is the pin diagram of a L293D motor controller. There are two Enable pins on l293d. Pin 1 and pin 9, for being able to drive the motor, the pin 1 and 9 need to be high. For driving the motor with left H-bridge you need to enable pin 1 to high. And for right H-Bridge you need to make the pin 9 to high. If anyone of the either pin1 or pin9 goes low then the motor in the corresponding section will suspend working. It's like a switch. 500 RPM 12V DC Geared Motor is high quality low cost DC geared motor. It has steel gears and pinions to ensure longer life and better wear and tear properties.

The gears are fixed on hardened steel spindles polished to a mirror finish. The output shaft rotates in a plastic bushing. The whole assembly is covered with a plastic ring. Gearbox is sealed and lubricated with lithium grease and require no maintenance. The motor is screwed to the gear box from inside. Although motor gives 500 RPM at 12V but motor runs smoothly from 4V to 12V and gives wide range of RPM, and torque. 500RPM 12V DC geared motors for robotics applications. Very easy to use and available in standard size. Nut and threads on shaft to easily connect and internal threaded shaft for easily connecting it to wheel.

### 3.3 SOFTWARE OF THE SYSTEM WEB PAGE ELEMENTS

HTML provides the basic structure of sites, which is improved and customized by other technologies like CSS and JavaScript. CSS is used to control presentation, layout and formatting. The commands can be sent through the web page with the help of internet. The user control command can be sent from anywhere in the world through web page. The robot is controlled from remote place which isolates the human being from dangerous environments.

PHP code may be executed with a command line interface (CLI), embedded into HTML code, or it can be used in combination with various web template systems, web content management systems, and web frameworks. PHP code is usually processed by a PHP interpreter implemented as a module in a web server or as a Common Gateway Interface (CGI) executable. The web server combines the results of the interpreted and executed PHP code, which may be any type of data, including images, with the generated web page. PHP can be used for many programming tasks outside of the web context, here it controls the standalone graphical applications and robotic vehicle movement and sensor value display.

The entire system is based on a Raspbian operating system like Linux platform. The Raspbian OS is based on Debian that optimizes the Raspberry Pi hardware. The programming language which is utilized for coding is Python. Python referred to as a widely used high-level programming language for general-purpose

programming. It handles and controls the raspberry pi hardware performance.

#### IV. CONCLUSION AND FUTURE WORK



Fig.9. Front view of robot

This paper presents an overview of the design, implementation, testing, and performance of an innovative robotic surveillance vehicle controlled wirelessly by a remote user, developed for the purpose of directing the movement and detection of the living, nonliving and metal objects and displaying status feedback to the operator through a web application.

Since these robots are implemented at the border region they should be designed to be water proof and should be able to loco mote in the rugged surface.

As they replace humans at the battle region it is necessary that the robot will be defense himself and protect our nation from the enemy. To make robot self-defense they can be designed to be equipped with a robot laser gun. Being a bomb disposal robot, it requires very fast movement. This is required as the bomb disposal squad have very less time to defuse the bomb and save the life of the human's. Therefore a fast robot is shall to be successful to dispose the bomb.

#### REFERENCES

[1] C. Micheloni, G. L. Foresti, C. Piciarelli and L. Cinque, "An Autonomous Vehicle for Video Surveillance of Indoor Environments," in IEEE

Transactions on Vehicular Technology, vol. 56, no. 2, pp. 487498.

- [2] W. F. Abaya, J. Basa, M. Sy, A. C. Abad and E. P. Dadios, "Low cost smart security camera with night vision capability using Raspberry Pi and OpenCV," 2014 International Conference on Humanoid, Nanotechnology, Information Technology, Communication and Control, Environment and Management (HNICEM), Palawan, 2014, pp. 1-6
- [3] Wi-Fi Robot for Video Monitoring & Surveillance System By Pavan C & Dr. B. Sivakumar, International Journal of Scientific & Engineering Research Volume 3, Issue 8, August 2012.
- [4] Arduino based Battlefield Assistive Robot By AhsanulHoque, Md. BaijidHasanShorif, ShekhNuruzzaman, Md. EftekharAlamHumanitarianTechbology conference (R10-HTC) 2017
- [5] Z.Wang, M. Zhou and N. Ansari, "movement of the robot ," in proceeding of IEEE Conference on Man and Cybernetics System Vol.4, pp.4045-4050, Washington DC, oct. 2003.
- [6] M.SenthamilSelvi, N. Suresh Kumar "Intelligent Smart Street Lighting System for the public and society", International Scientific Global Journal in Engineering, Science and Applied Research (ISGJESAR), Vol.1, No. 1, May 2016. pp. 18-28.
- [7] U. Bokade and V. R. Ratnaparkhe, "Video surveillance robot control using smartphone and Raspberry pi," 2016 International Conference on Communication and Signal Processing (ICCSP), Melmaruvathur, 2016, pp. 2094-2097.
- [8] The Robot control using the wireless communication and the serial communication" By Jong HoonAhnn, Master of Engineering Thesis in Electrical and Computer Engineering Cornell University, 2007
- [9] Ewald, Hartmut&Krüger, Hendrik, "Inductive sensors and their application in metal detection", 1st International Conference on Sensing Technology, Palmerston North, New Zealand, November 2123, 2005
- [10] S. Naskar, S. Das, A. K Seth, A. Nath. 2011. Application of Radio Frequency Controlled Intelligent Military Robot in Defense.

Communication Systems and Network Technologies (CSNT), International Conference, art. 7-50.

- [11] J. Zhang, G. Song, G. Qiao, T. Meng and H. Sun, "An indoor security system with a jumping robot as the surveillance terminal," in IEEE Transactions on Consumer Electronics, vol. 57, no. 4, pp. 1774-1781, November 2011.
- [12] M. SenthamilSelvi, Mrs.S.Jansi Rani, M.FaesaFathima Presented a paper in National Level Conference on Advances In Materials Science And Engineering For Societal Applications titled "Energy Harvesting sensors and its applications" from 18th& 20th July 2018 sponsored by DST -SERB and DRDO at SREC, Coimbatore.