

Patient Health Monitoring with an Arduino Based Smart Mirror

DIKSHITA BADWAIK¹, EKTA GAME², POOJA ZADE³, PRANALI KATHOTE⁴, PROF. GAYATRI PADOLE⁵

^{1, 2, 3, 4} Student, Department of Electronics & Telecommunication, J D College of Engineering & Management, Nagpur

⁵ Professor, Department of Electronics & Telecommunication, J D College of Engineering & Management, Nagpur

Abstract— *In examination with varied alternative analysis papers on sensible mirror systems, it had been inherent to implement advanced functionalities and were developed for specific functions like rate, O level, and temperature. web of Things (IoT) technologies with sensible sensors play a significant role in observance and dominant applications in several areas. the chance to use sensible mirror technology in health care to predict and monitor aspects of health and illness may be a natural however principally underdeveloped plan. we tend to envision that sensible mirrors comprising a mix of intelligent hardware and software packages may establish refined, nonetheless clinically relevant changes in physique and look. The Arduino works because of the host controller during this structure. The model functions once the Wi-Fi chipset on the Arduino is connected to the web Network.*

Indexed Terms-- *Internet of Things (IoT), Smart Mirror, Arduino, Wi-Fi Module.*

I. INTRODUCTION

For health observance, a range of approaches area unit on the market and a range of sensors. Early health observance approaches were clinical, during which folks may learn to manage sure physiological functions by dynamically the beliefs and perceptions that caused them with the assistance of accomplished therapists, however, they'd to travel to specific sites wherever the technology was on the market. people will currently utilize medical specialty sensors and also the web of Things to stay track of physiological performance from afar (IoT). Sensors are units employed in a range of gadgets, as well as phones,

watches, and alternative electronic devices. for people United Nations agency area unit capable of mistreatment such devices, this technology is improbably valuable. older people, on the opposite hand, United Nations agency area unit less ready to use such instrumentation, need health observance systems over persons of alternative ages. This chapter explains a way to use mirrors to form a good health observance system that may be utilized by anyone of any age. The physiological information is collected by the medical specialty sensors within the mirror and communicated to medical personnel so that they will learn a lot regarding the patient's health. Doctors will keep an eye fixed on their patient's health from afar mistreatment this methodology.

In this study, we tend to center on a sensible mirror, that is one in every one of these gadgets. a sensible mirror is an Associate in a Nursing device that functions as a mirror but may communicate with users and show info like date, time, and weather on the screen, all whereas being hidden behind a reflective surface. good mirrors are available in a range of shapes, sizes, and applications that may be employed in the tutorial, general, and medical settings mistreatment varied implementation strategies and programming languages.

Previously, the good mirror served solely as an Associate in the Nursing interface for displaying generic info. By desegregation of a sensing element placed within the good mirror, the mirror will currently predict the presence of the user before it, creating a lot of interaction. good mirrors show information that's helpful to each user. It's helpful in a very form of things. within the industry, for instance,

the mirror could act as an adviser, guiding customers through a simulation to help them to settle on their apparel. what is more, one of the foremost vital fields that use the good mirror to deliver a therapeutic and medical recommendation to patients is medication good mirrors are utilized as a learning aid for pupils?

There area unit a range of health observance ways on the market and plenty of forms of sensors that may be used. Early health observance techniques were clinical, during which an individual may learn to regulate specific physiological functions by dynamically the thoughts and perceptions that made them with the assistance of trained therapists, however, folks had to travel to specific locations wherever the technology was on the market.

Individuals will currently use medical specialty sensors to remotely monitor physiological functioning via the web of Things (IoT). Sensors area unit employed in a range of gadgets, as well as cell phones, watches, and alternative wear-ables. for people United Nations agency will use such devices, this technology is kind of helpful.

Elderly persons, United Nations agency area unit less ready to operate such instrumentation, need health observance systems at a better rate than alternative age teams. This chapter provides a basic health observance system supported by mirrors, which can be utilized by anyone of any age. The physiological information is collected by medical specialty sensors within the mirror and communicated to medical personnel to supply them with info regarding the patient's health standing. Doctors will use this methodology to remotely monitor their patient's health.

II. INTERNET OF THINGS (IOT)

The Internet of Things (IoT) may be a phrase for physical things that may connect with and share knowledge with different devices and systems over the Internet or different communication networks. It includes sensors, computing power, software, and different technologies. The term "internet of things" is deceptive as a result of devices don't have to be compelled to be connected to the general public internet; instead, they have to be connected to a network and addressed individually. owing to the

convergence of many technologies, together with omnipresent computing, commodity sensors, more and more powerful embedded systems, and machine learning, the sphere has progressed. The web of Things will operate each severally and put together due to ancient disciplines like embedded systems, wireless device networks, management systems, and automation. lights, thermostats, home security systems, cameras, and different home appliances that may be controlled by devices coupled to it system, like good phones and smart speakers, are all things that contribute to the patron market's embrace of the "smart home" plan. In care, the web of Things is additionally used.

III. COMPONENTS

- ARDUINO: Arduino is an ASCII text file refined microcontroller that will be systematically employed in a system. It is often utilized for low-tension applications starting from three.3 to 5.5 V. it's utilized to produce electricity for star panels. The universal serial bus is employed to attach Arduino to a laptop or computer (USB), Arduino principally uses C and C++ language principles. The user will utilize Arduino to form various modifications in IoT utilizing numerous programming languages.
- TEMPERATURE SENSOR: We'll be employing a GY-906 MLX90614 Non-Contact exactitude measuring instrument for this project. it is a high-precision infrared non-contact measuring instrument module with an Associate in Nursinging I2C interface that runs on either 5V or three.3V. The key distinction between this measuring instrument and most others is that it takes temperature readings while not contacting the item whose temperature is being checked. this is often helpful for observing the temperature of moving things, like a spinning motor shaft or objects on a moving conveyor. The sensing element will browse a large variety of temperatures since it's not invariably exposed to an equivalent temperature that its observation. An intrinsical optical filter on the sensing element blocks out visible and near-infrared lightweight to scale back their impact on the activity. It will use the I2C bus to speak temperature or modify settings. It will ceaselessly convey the temperature employing a PWM signal,

with the duty cycle of the signal representing the temperature. It is used as a thermal switch to toggle the output at a pre-programmed trip purpose, like during a thermostat.

- PULSE OXIMETER HEART SENSOR:** MAX30100 is being utilized throughout this project it's a detector that incorporates a pulse measuring instrument and a significant sign monitor. It's an associate in the nursing associate optical detector that gets its measurements by emitting a pair of wavelengths of sunshine – red and infrared – from a pair of LEDs, then police investigate the absorption of pulsing blood with a photo-detector. This diode color combination is nice for reading data with the tip of one's finger. The digital output data is persisted in an exceedingly very 16-deep accounting within the device, and it's customizable through code registers. It connects to many microcontrollers through an associate in nursing associate I2C digital interface. shut light-weight cancellation (ALC), a 16-bit letter of the alphabet delta ADC, and a proprietary distinct temporal filter compose the heartbeat oximetry theme at intervals the MAX30100. It operates at very low power, making it wonderful for high-powered systems. The MAX30100 desires Associate in Nursing influence supply ranging from one.8 to 3.3 volts. wearable gadgets, fitness facilitate devices, medical observation devices, and different devices can all have the advantage of it. The MAX30100 runs on one.8V and 3.3V power sources, and it's progressing to be turned down by code with very little or no standby current, allowing the power supply to be connected the smallest amount a few times.
- SMART MIRROR:** A Smart Mirror could be a two-way mirror with a constitutional show on the backside of the glass. On the mirror's surface, the show will show this time, prognosis, a news feed, scheduled appointments, and more. The capability to show any info you select on a wise Mirror is what makes it "smart." native weather forecasts, news bulletins, your forthcoming calendar agenda, social network feeds, and different info will all be displayed on a wise mirror. you'll simply style a wise mirror to show no matter what info you want.

- WI-FI MODULE:** The ESP8266 WiFi Module may be a self-contained SOC with an Associate in Nursing integrated TCP/IP protocol stack which will provide any microcontroller access to your WiFi network. This module contains a powerful enough on-board process and storage capability that enables it to be integrated with the sensors and different application-specific devices through its GPIOs with nominal development up-front and nominal loading throughout the runtime.
- BLOCK DIAGRAM:**

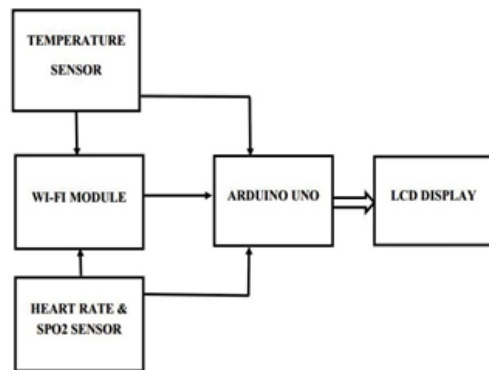

Fig 1: Block Diagram of Patient Health Monitoring with an Arduino Based Smart Mirror

- CIRCUIT DIAGRAM:**

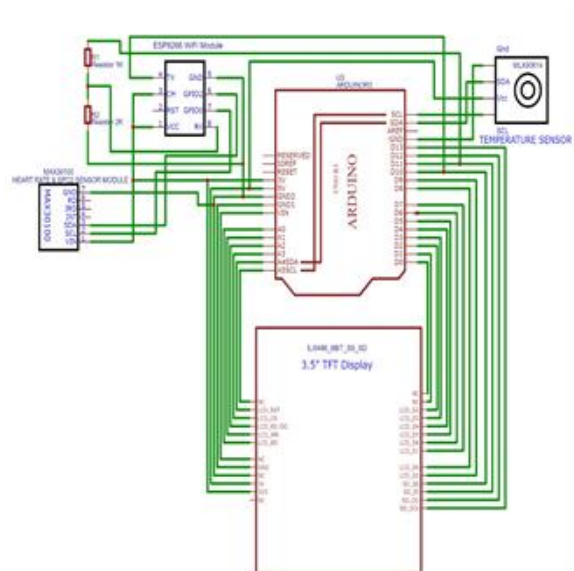

Fig 2. : Circuit Diagram of Patient Health Monitoring with an Arduino Based Smart Mirror

• APPLICATIONS OF SMART MIRROR:

[1] A sensible mirror that is a private assistant to deal with the matter of your time management that a lot of individuals expertise. It shows time, weather, and news, among alternative things. Users will browse and alter daily schedules for various users, yet scan and reply to emails. The mirror conjointly contains a graphical keyboard that users will use to act with it.

[2] Sensible mirror to be used in smart home communications. This sensible mirror is critical as a result of its economical, intelligent, safe, and fairly priced. additionally, we tend to create this sensible mirror mistreatment the unidirectional photography plan. In general, the results are incontestable that the sensible mirror improves safety by examining the user's face to antecedently recognized faces and causing an alarm if non-conformity to the owner standing happens.

[3] The system was created with either AN Arduino Uno or a Raspberry Pi. A plasma panel was conjointly accustomed to showing some system capabilities like face and voice recognition, speech playback, device, Wi-Fi property, and a wear indicator. The management module, show module, clock module, wireless transceiver module, and Bluetooth module all created up the sensible mirror. In general, the findings unconcealed that a low-priced sensible mirror is also created utilizing straightforward materials and an Arduino Uno or Raspberry Pi.

[4] A sensible mirror that acts as a virtual fashion advisor, analyzing, estimating, and recommending applicable apparel and outfits. Users are target-hunting to work out what to decorate mistreatment AR and gesture recognition beneath fashion directions. In the second visual image, there are icons to settle on the outfits.

[5] FitMirror, a sensible mirror, was made-up as an interactive appliance to boost the user's mood and motivation whereas conjointly having a decent impact on the user's feelings. FitMirror conjointly encourages users to induce up and total very first thing in the morning. additionally, the mirror was coupled to the humanoid match program, which displayed the users' exercise knowledge, yet their pressure and stress levels, every week. bit or voice are 2 ways during which the user will communicate with the device.

[6] An automatic personal cosmetics system was created with the assistance of a sensible mirror. The device uses a sensible mirror to spot makeup aspects

that are best appropriate for a user's face by applying them to facial photos. moreover, the system was created mistreatment Machine Learning (ML) and AI approaches throughout the analysis of users' faces.

IV. METHODOLOGY

1. Smart Mirror as a Mirror:

In the mirror, we can see ourselves as we would in a plane mirror. When grooming with the help of a two-way mirror containing a high concentration of aluminium.

2. Smart Mirror as an Information System:

Temperature details are obtained using MLX90614 temperature sensor. Heart Rate & SPO2 parameter is given by MAX30100 Heart Rate & SPO2 sensor.

3. Smart Mirror as to do Board:

A rising intelligent house device with doubtless wide locomote applications for health care outside of ancient medical settings is a good mirror. Advances in sensors and computing currently provide capabilities for creating correct forecasts regarding significant changes in health, watching illness progression, and trailing response to treatments, which represent important areas for innovation in digital health.

V. FUTURE SCOPE

An art movement good mirror system that gives data like time, date, correct temperature, and humidness, and therefore the latest news whereas trying and grooming ahead of the mirror and conjointly helps in malefactor detection. In Our Future Work, we'll investigate however the encompassing context of the user and therefore the atmosphere can be utilized to produce optimum service experiences within the home atmosphere. The system will be created way more helpful to the users by adding a lot of practicality like desegregation lightweight settings, speech process, etc.

VI. CONCLUSION

Technology is incredibly vital in human life, particularly in the field of IoT, it'll still develop inefficaciously decision-making in step with orders. The application of IoT is currently setting out to be

acknowledged by many of us because of its users that are incredibly useful forever in all aspects. One example of the floating IoT is the good mirror that may facilitate individuals to begin the day, by displaying the information required. The good mirror can still develop with voice management that may later be connected to a smart home, like turning off the lights. This analysis appearance at what the magic mirror will do for the future. Good mirror prototypes and structural designs have the potential to improve health care. What isn't clear is when or how the prototypes will make their way into the market and become an important part of assessing an individual's health to help the healthcare system as a whole. We believe that the present digital revolution, which uses deep learning to better code packages and hardware, will take the lovely mirror. In the coming years, I envision widespread usage in health-related applications in clinics and at home, while keeping their value and security at an enormous access level.

REFERENCES

- [1] D. Young, Dan Tianjin Key, 'Design of Smart Mirror using Raspberry Pi', Laboratory of Information Sensing & Intelligent Control, Tianjin University of Technology and Education, 2018.
- [2] Mohammad Ghazal, Tara Al, Yasmina Al Khalil, Mohammad and Hassan, 'A Mobile Programmable Smart Mirror for ambient IoT Environments', IEEE paper projected in 2017.
- [3] Y. Sun, L. Geng, and K. Dan, 'Design of smart mirror based on raspberry pi's 2018 International Confpi'se on Intelligent Transportation, Massive knowledge & good town, IEEE, 2018.
- [4] R. A. Nadaf, S. Hatture, P. S. Challigidad, and V. M. Bonal, 'Smart mirror using raspberry pi for human monitoring and home security in International Conference on Advanced Informatics for Computing Analysis, Springer, 2019.
- [5] B. R. Sven Von Hollen, 'Smart mirror devices for smart home and business in International Conference on Innovations for Community Services, Springer, 2018.
- [6] B. Cvetkoska, N. Marina, D. C. Bogatinoska and Z. Mitreski, 'Smart mirror E-health assistant — Posture analyze rule projected model for upright posture' IEEE, 2017
- [7] Piyush Maheshwari, Maninder Jeet Kaur, Sarthak Anand. 'Smart Mirror: A Reflective Interface to mamaximizeroductivity' International journal of computer applications, 2017.
- [8] Mayuri Katole, Manisha Khorgade, 'Novel Approach Of DeDesigning Smart Mirror Using ReRaspberrypi' International journal of engineering technology science and analysis IJETSR, 2018.
- [9] M. M. Yusri et al, 'Smart mirror for smart life' 2017 sixth ICT International Student Project Conference.
- [10] Riccardo Miotto, Matteo Danieleto, Jerome R. Scelza, Brian A. Kidd, and Joel T. Dudley, 'Reflecting health: smart mirrors for pepersonalizededicine' Nature Partner Journals, 2018.
- [11] Sara Colantonio, Giuseppe Coppini, Danila Germanese, Daniela Giorgi, 'A smart mirror to promote a healthy lifestyle' printed by Elsevier Ltd, 2015