

Solar Based Floor Cleaner Robot Using Arduino Uno

Mrs. K. Bhargavi¹, B. Kavya², P. Vamshi³, P. Shiva⁴, K. Sai Prakash⁵

¹Assistant Professor, Department of Electronics and Communication Engineering, Teegala Krishna Reddy Engineering College, Meerpeta, Hyderabad, 500097

^{2,3,4,5} Student, Department of Electronics and Communication Engineering, Teegala Krishna Reddy Engineering College, Meerpeta, Hyderabad, 500097

Abstract: Households of today are becoming smarter and more automated. Home automation delivers convenience and creates more time for people. Domestic robots are entering the homes and people's daily lives, but it is yet a relatively new and immature market. However, a growth is predicted and the adoption of domestic robots is evolving. The purpose of this project is to design and implement a Cleaning Robot Autonomous. Floor Cleaner Robot is designed to make cleaning process easier rather than by using manual vacuum. The main objective of this project is to design and implement a Dry and Wet robot prototype. Robot will have several criteria that are user friendly.

With the advancement of technology, automated floor cleaning machines are getting more attention of researchers to make life of mankind comfortable. The concept is developing in economic countries but the reasons for non-popularity is the design complexity, cost of machines, and operational charges in terms of power tariff. In this paper, a semi-automated floor cleaning machine is proposed. This is capable of cleaning floor effectively in dry as well as wet cleaning tasks. This floor cleaning machine is designed by keeping the basic considerations for reduction in cost and efforts while being environmentally friendly and easy to handle.

Keywords: Arduino Uno, Ultrasonic Sensor, L293D Motor Driver IC, LCD Display, Lead Acid Battery.

I. INTRODUCTION

Cleaning is important work approximate every place. Sometimes this is easy and sometimes difficult. Sometimes we assigned people for purpose of cleaning and pay money and sometimes cleaning is required in areas where presence of living being dangerous so we cannot assign living being in every place. Some places are so that have a large floor area in that place for

cleaning purpose we need more than one person so we required some technique to compensate these problems. Automation is a great solution of this problem. So, we make an autonomous floor cleaning robot. Ultrasonic sensor is the most important component for autonomous floor cleaning robot because ultrasonic sensor works as eyes of robot. Ultrasonic sensor useful for turning of robot by sensing the obstacle or wall. Sensing distance range set by programming. In this range robot sense the obstacle and turn back, cleaning reason we need more than one individual so we required some method to repay these issues. In headway of science a robot come in light however it works by a faculty. To keep away from this limit of faculty we require more innovations. Computerization is an extraordinary arrangement of this issue. So, we make a self-governing floor cleaning robot that worked by web of things and Arduino programming. Families of today are getting more astute and furthermore more mechanized. Home robotization conveys accommodation and makes more opportunity for individuals. Homegrown robots are entering the homes and individuals' everyday lives, yet it is yet a moderately new and juvenile market. Be that as it may, a development is anticipated and reception of homegrown robots is advancing. Reason for this undertaking is plan and actualize a floor cleaner Robot Autonomous. Cleaner Robot is intended to cause cleaning cycle to become simpler as opposed to by utilizing manual vacuum. The primary target of this undertaking is to plan and execute a robot model by utilizing Arduino Uno, engine driver and to accomplish the objective of this venture. Robot will have a few measures that are easy to use. Fully automatic and Semi-Automatic machines available in the market are of high ranges and high weights. So, keeping the focus on weight as well as cost, they are not affordable to all such as organization committee of hotels, hospitals, hostels. Hence, there is need to design and develop a

floor cleaning machine which is multi use and cost effective. In some places such as bus stations, temple halls, byres the floors are not regularly cleaned due to non-availability of machines. There is no machine in the markets which can be used on smooth as well as rough surface floors. Considering weight criteria, machine assembly, handling the machine is very flexible. This machine is affordable to all because of its uses and cost.

II. LITERATURE SURVEY

AKASH NAGTODE (2017) “Solar operated floor cleaning machine. He had made a project on cleaning system based on solar power. For this he has used Pv panel which converts particle of energy (photons) into electricity. He uses this clean energy to power his cleaning machine”. 1.M RANJIT KUMAR (2016) “The regular floor cleaning machines is most generally utilized as a part of airplane terminal stages, railroad stages, healing centers, transport stands, and shopping centers and in numerous other business places. These gadgets require an electrical vitality for its activity and not easy to use. In India, particularly in summer, there is control emergency and the vast majority of the floor cleaning machine isn't utilized successfully because of this issue, especially in transport stands. In this work, demonstrating and investigation of the floor cleaning machine was finished utilizing appropriate financially accessible programming. From the limited component investigation, we watch that the feeling of anxiety in the physically worked floor cleaning machine is inside as far as possible”. 2. SANDEEP. J. MESHRAM ET AL [2016] “Design and Development of Tricycle Operated Street Cleaning Machine” – He has developed the street cleaning machine by tricycle operated. In this research article. He framed a model especially for rural area. He concluded that the cleaning is less effective in streets”.3. MOHSEN AZADBAKHT ETAL [2014] “Design and fabrication of a tractor powered leaves collector machine equipped with suction-blower system”- “The authors explained about the fabrication of leaves collector machine by tractor powered blower. He has framed the machine by using chassis, pump, blower, gearbox, hydraulic jack. They concluded total power consumption of that machine is around 14634 W which can cover up to 20m range in distance”. 4.MANREET KAUR [2014] “Design and fabrication of floor cleaner robot (manual and automatic). the author designed a robot to clean floor in both automatic mode

as well as manual mode. His robot was equipped with IR sensors for obstacle detection, four motors and water pump. He concluded with convenience of dual mode operation of easy floor cleaning”.

5. MANYAJAIN, PANKAJ SINGH RAWAT (2016) “This project is used for domestic and industrial purpose to clean the surface automatically. When it is turned on, it sucks in the dust by moving all around the surface (floor or any other area) as it passes over it. In the modern era, the automatic floor cleaner is required. Thus, the cleaner is designed in such a way that it is capable of cleaning the area reducing the human effort just by starting the cleaning unit”. 6.SAHIL BHARTI, S.R. SANDHAVE (2016) “To develop an automated cleaning assistance this helps in cleaning flat surface with the ease of remote control with greater efficiency at work. The surface cleaning machine that is proposed in this project is the device that helps in cleaning of surface. There are many functions that have to coordinate for the motion control”.

III. METHODOLOGY

In this proposed system is automatic solar-based floor cleaning robot is to provide an efficient and autonomous solution for cleaning floors without human intervention. The robot is designed to navigate around obstacles, detect and avoid obstacles in its path using an ultrasonic sensor, and clean the floor using a brush. The use of solar panels and rechargeable batteries allows the robot to operate for extended periods without the need for frequent charging or replacement of batteries. The goal is to create a reliable, low-maintenance, and eco-friendly cleaning solution that can be used in homes, offices, hospitals, and other commercial or industrial settings. Ultimately, the aim of the automatic solar-based floor cleaning robot is to save time and effort while maintaining a clean and hygienic environment.

Description:

The robot is switched on and begins its cleaning process. The ultrasonic sensor, mounted on the front of the robot, emits high-frequency sound waves that bounce off objects in the environment. The sensor then detects the time it takes for the sound waves to return and calculates the distance between the robot and the object. The robot's microcontroller receives the data

from the ultrasonic sensor and determines if there is an obstacle in the robot's path. If an obstacle is detected, the robot will change direction or stop to avoid the obstacle. The robot uses its wheels or tracks to move around the environment while constantly checking for obstacles using the ultrasonic sensor. It may follow a pre-programmed path or use an algorithm to navigate around the area. As the robot moves, it uses a cleaning mechanism such as a brush or mop to pick up dirt and debris from the floor. The cleaning mechanism may be mounted on the underside of the robot or may be detachable for easy cleaning. The robot may be powered by a rechargeable battery that can be charged using a solar panel or power outlet. As the robot moves around, it uses its battery power to operate the motors and cleaning mechanism. Once the cleaning process is complete or the battery runs low, the robot will return to its charging dock or shut down.

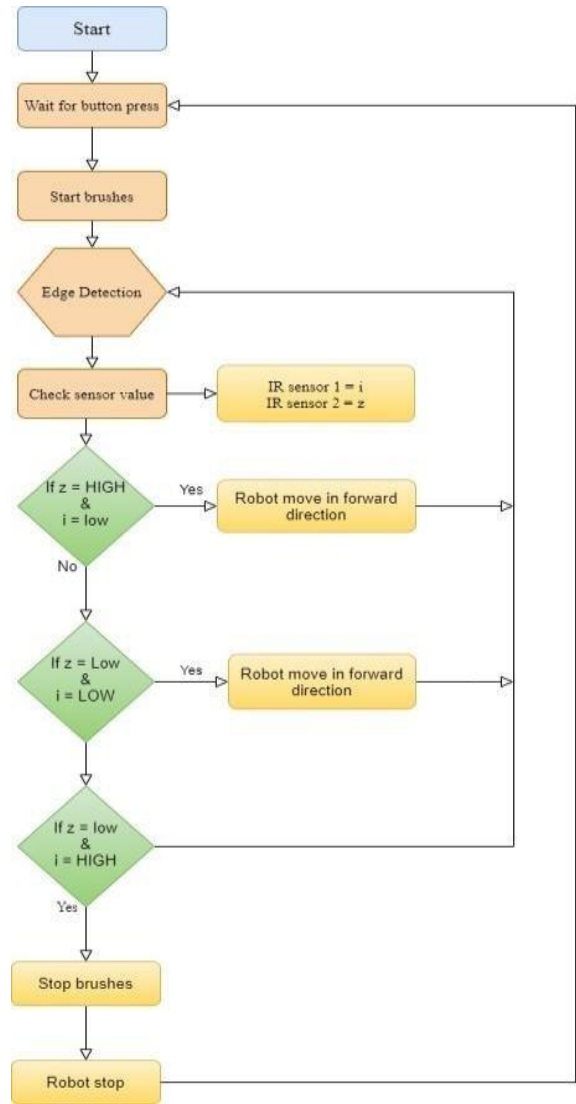

Figure 1: Flowchart
IV. BLOCK DIAGRAM

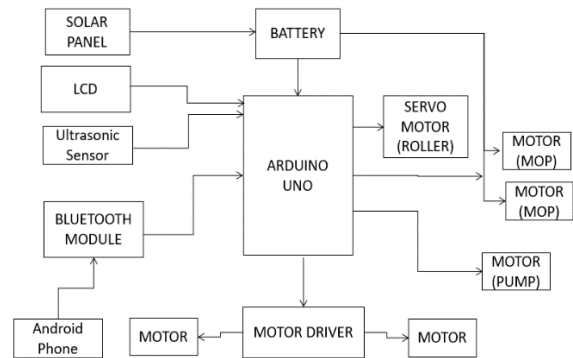

Figure 2: Block Diagram
V. RESULT

An automatic floor cleaning robot using ultrasonic sensors is a feasible concept. Ultrasonic sensors use sound waves to detect objects and measure distances, making them a popular choice for obstacle detection and avoidance in robotics. A robot designed to clean floors using ultrasonic sensors could use them to detect walls, furniture, and other obstacles in its path. This would enable the robot to navigate around obstacles and avoid collisions. Additionally, the ultrasonic sensors could be used to detect the floor's surface and adjust the robot's cleaning approach accordingly.

However, it's important to note that ultrasonic sensors have some limitations. For example, they can be affected by environmental factors such as temperature and humidity. Also, ultrasonic sensors are not effective at detecting transparent or highly reflective surfaces. Overall, an automatic floor cleaning robot using ultrasonic sensors is a promising concept, but it would require careful design and testing to ensure that it functions effectively and reliably in real-world conditions.

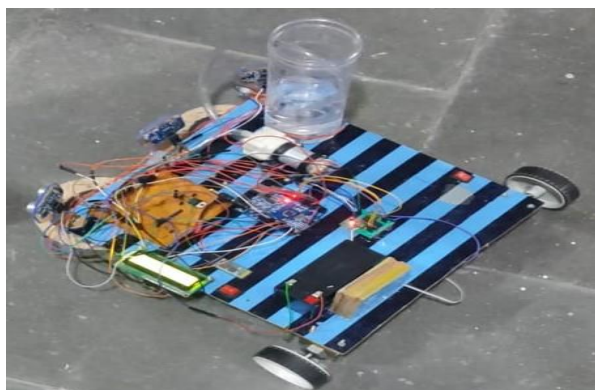

Figure 3: Output
VI. CONCLUSION

The use of innovative technology not only reduces cost significantly but also reduces the human effort while increasing the effectiveness of floor cleaning. Reduced human effort means more frequent floor cleaning which results in increase in overall cleanliness and supports healthy well-being. Small steps in technological advancement like this will have higher impact in long run-in future, making India a better country. In our project we introduced a floor cleaning machine. One of the key motives of our project was to cover the aspects of cleanliness in the society. The multiple applications provide a wide range of functions. Since our machine is Solar operated, it helped in making an environmentally friendly project.

VII. FUTURE SCOPE

If panel used of high watt, then the machine can be used during night time for garden lighting or room lighting. Because we can store more power. And at night time however you keep it aside. So, the power in the battery can be used for this purpose. By using one valve in the pipe, we can also use it for gardening i.e., pouring water for plants. By connecting one box type carrier we can use it to transport files, books or other stuffs from one place to other in office or any other place.

REFERENCE

- [1] C. Alex and A. Moscaritolo, "The Best Robot Vacuums for 2020," PCMag, 2020. [Online]. Available: <https://www.pcmag.com/picks/the-best-robot-vacuuiLS?test uuid—0 I j rZgWN Xh mA1 oC i7Zl IXevj&test variantb>.
- [2] A. K. Bordoloi, F. Islam, J. Zaman, N. Phukan, and N. M. Kakoty, "A floor cleaning robot for domestic environments," in ACM International Conference Proceeding Series, 2017, vol. Part F132085, pp. 1-5.
- [3] H. Rashid, A. Mahmood, S. Shekha, S. M. T. Reza, and M. Rasheduzzaman, "Design and development of a DTMF controlled room cleaner robot with two path-following method," in 2016 19th International Conference on Computer and Information Technology (ICIT), 2016, pp. 484—489.
- [4] Arduino.cc, "Arduino UNO Rev3." [Online]. Available: <https://store.arduino.cc/arduino-uno-rev3>.
- [5] J. Forlizzi and C. DiSalvo, "Service robots in the domestic environment: a study of the roomba vacuum in the home," in Proceeding of the 1st ACM SIGCHI/SIGART conference on Human-robot interaction - HRI •06, 2006, pp. 258-265.
- [6] "HC-06 Bluetooth Module." [Online]. Available: <https://components101.com/wireless/hc-06-bluetooth-modulepinout-datasheet>.
- [7] M. Ranjit Kumar and N. Kapilan, "Outline and Examination of physically worked floor cleaning machine," IJERT ISSN: 2278- 0181 Vol. 4 Issue 04, April-2015.
- [8] Sandeep. J. Meshram, Dr. G.D. Mehta - "Design and Development of Tricycle Operated Street Cleaning Machine" - Journal of Information, Knowledge and Research in Mechanical Engineering ISSN 0975 – 668X| Nov 15 to Oct 16 | Volume– 04, Issue- 01.

[9] Liu, Kuotsan, Wang Chulun, A Technical Analysis of Autonomous Floor Cleaning Robots Based on US Granted Patents, European International Journal of Science and Technology Vol. 2 No. 7 September 2013, 199- 216. Design and fabrication of floor cleaner robot (manual and automatic) International Journal of Computer Applications (0975 – 8887) Volume 97– No.19, July 2014.

[10] Dr.J.Hamee Hussain, R.Sharavanan- FLOOR CLEANING MACHINE BY REMOTE CONTROL. International Journal of Pure and Applied Mathematics Volume 116 No. 14 2017, 461-464,

[11] DESIGN AND DEVELOPMENT OF CLEANING SYSTEM SAHIL BHARTI, 2S.R. SADHAVE.

[12] Automatic Floor Cleaner Manya Jain¹, Pankaj Singh Rawat International Journal of Soft Computing and Artificial Intelligence, ISSN: 2321-404X.

[13] SOLAR OPERATED FLOOR CLEANER MACHINE Akash A. Nagtode¹, Amit P. Kamdi², Issue 6-ICRTEST January 2017.

[14] Liu, Kuotsan, Wang Chulun, A Technical Analysis of Autonomous Floor Cleaning Robots Based on US Granted Patents, European International Journal of Science and Technology Vol. 2 No. 7 September 2013, 199-216.

[15] Imaekhai Lawrence – —Evaluating Single Disc Floor Cleaners – An Engineering Evaluation, Innovative Systems Design and Engineering, Vol 3, No 4, 2012, 41-44.

[16] Mohsen Azadbakht, Ali Kiapey, Ali Jafari—Design and Fabrication of a tractor powered leaves collector equipped with suction blower system – September, 2014 AgricEngInt: CIGR Journal Open access at <http://www.cigrjournal.org> Vol. 16, No.3.

[17] Abhishek Chakraborty, Ashutosh Bansal – —Design of Dust Collector for Rear Wheel of Four-Wheeler – International Journal of Emerging Technology and Advanced Engineering, Volume 3, Issue 7, July 2013, 199-216.

[18] Prof. Dr. A. Muniaraj Professor, Department of Mechanical Engineering, Kings Engineering College, Chennai, Tamilnadu, India ISSN 2394-3777 (Print) ISSN 2394-3785.

[19] Haslam, R.A. and Williams, H.J, —Ergonomics considerations in the design and use of single disc floor cleaning machines, Applied Ergonomics, 30,391-399.2010.

[20] Ajay P John—Implementation of an Automated Smart Robotic Floor Cleaner. B. Tech Student, Dept. of

E.C.E., HKCET, Pampakuda, Ernakulam, India.