

Mathematical Modeling of Indirect Field Oriented Controlled Induction Motor

Mr.Suraj R Karpe¹, Mr.Sanjay A Deokar², Mr.Gajanan Malwatkar³

Students Department of Technology, SPPU, Pune, Maharashtra, India¹

Professor, Electrical Engineering, Zeal College of Engineering, Pune, Maharashtra, India²

Professor, E&TC Engineering, Zeal College of Engineering, Pune, Maharashtra, India³

Abstract: *Since induction motors are often employed in industrial settings, speed control has been a significant topic of study. The construction of the squirrel cage induction motors is straightforward, inexpensive, and durable, and they require minimal maintenance. These benefits have led to its widespread usage for fixed speed applications in several sectors. The major goal is to switch out the DC motor for an induction motor, combine the benefits of both motors into a variable speed brushless motor drive, and solve any related issues. However, industrial applications demand effective IM drive control. The mathematical models of induction motors (IM) are known to be extremely nonlinear and time-variant, making control of IM challenging. The challenges of controlling the induction motor for precision applications have been resolved by the invention of vector control methods. The notion of vector control method is explained in this essay. Vector control fundamentally has two general approaches. The direct approach, also known as feedback, and the indirect method, also known as feed forward, are the two. Due to its relatively easy construction when compared to the Direct Torque Controlled (DTC) approach, Indirect Field Oriented Control (IFOC) induction motor drives are employed in high performance systems in a variety of industrial applications. The indirect field-oriented control of induction motors is the main topic of this study.*

Keywords: *Induction motor, indirect field oriented control, vector control, space vector pulse width modulation (SVPWM).*

I. INTRODUCTION

Due to its benefits over DC motors, including its durability, low cost, small size, and weight, improved dependability, and higher efficiency, it is used in industrial applications. High performance electric drives with the ability to precisely execute torque, speed, or position demands are in demand. The control of AC electric machines is acknowledged to be a significant development and a possibility for real-time implantation applications as a result of the significant

advancement in power electronics and micro-computing. The fundamental actuator for industrial purposes is generally acknowledged to be the induction motor. However, because the induction motor drive is a complex non-linear system and the rotor variables cannot be directly monitored, developing an accurate induction motor control is difficult. Additionally, the physical properties vary depending on the working environment. Like DC motors, high beginning torque is also challenging to obtain. Different methods can be used to control induction motors. The most popular methods are:

- a) Constant voltage/frequency control (V/F)
- b) Field orientation control (FOC)
- c) Direct torque control (DTC).

The first is referred to as a scalar control because it just modifies the magnitude and frequency of the voltage or current without taking into account the values of the motor variables in real time. It is an open-loop control, meaning that no knowledge of the motor's characteristics is necessary. As a result, it is an affordable, straightforward option for low-performance applications like fans and pumps. The other two techniques fall under the category of space vector control since they make use of the magnitude and angular location of space vectors for motor variables like flux and voltage. In addition to accurate speed regulation, rapid dynamic reaction, and functioning above base speed, vector control has a variety of advantages. This control method has been shown to be well suited to all types of electrical drives used in conjunction with induction machines and can deliver the same performance as an independently excited DC machine. The field-oriented control of induction motors is the main topic of this essay. The stator currents of a three-phase AC electric motor are recognized as two orthogonal components that may be seen as a vector in the vector control approach, also

known as field-oriented control (FOC). Controlling the stator currents, which are represented by a vector, is the function of the field-oriented control. A three-phase time- and speed-dependent system is transformed into a two-coordinate (d and q frame) time-invariant system via this control, which is based on projections. A structure resembling a DC machine control is produced by these projections and transformations. The torque component, which is aligned with the q coordinate, and the flux component, which is aligned with the d coordinate, are required as input references for FOC machines. It is possible to study the three-phase voltages, currents, and fluxes of AC motors in terms of complicated space vectors. Field Orientated Control manages immediate electrical quantities since it is only dependent on projections. The control is accurate as a result of every working process (steady state) of the limited bandwidth mathematical model.

II. DYNAMIC MODELING OF INDUCTION MOTOR

Various reference frames can be used to create the induction motor model. As a result, it is simpler to fix the reference frame to a certain motor number and modify the model as necessary. The majority of induction motors are of the rotary type, which essentially have a revolving rotor and a fixed stator. The three phase values are converted into two phase direct and quadrature axes quantities to generate the dynamic model of the induction motor. The following equation may be used to calculate the machine's electromagnetic torque:

$$Te=32p2(\psi dsiqs-\psi qsids) \dots\dots\dots(1)$$

$$\text{where, } \psi ds=Lsids+Lmidr \dots\dots\dots(2)$$

$$\text{and } \psi qs=Lsiqs+Lmiqr \dots\dots\dots(3)$$

III. INDIRECT FIELD ORIENTED CONTROL

The most often used approach for indirect vector control based on rotor flux links entails lining up the stationary frame's direct axis and quadrature axis with the rotor flux frame. Therefore, to convert the variables from stationary frame to synchronous frame, unit vectors are needed. These unit vectors are produced using the following feed-forward technique in this method: The direct axis and quadrature axis rotor fluxes are expressed as

$$d\psi drdt+RrLr\psi dr-LmLrRrids-(\omega e-\omega r)\psi qr=0 \dots\dots\dots(4)$$

$$d\psi qrdt+RrLr\psi qr-LmLrRriqs-\omega e-\omega r\psi dr=0 \dots\dots\dots(5)$$

$$\text{For decoupling control, } \psi qr=0 \dots\dots\dots(6)$$

$$\text{Andhence } d\psi qrdt=0 \dots\dots\dots(7)$$

So the entire flux is directed along d-axis. Substituting equation (6) and (7) in equation (4)&(5) we get,
 $\omega e-\omega r=LmRr\psi drLriqs \omega sl=\omega e-\omega r \dots\dots\dots(8)$

$$\text{If rotor flux } \psi qr \text{ is constant, then } \psi r^*=\psi dr$$

Hence slip speed can be calculated from q-axis reference current and rotor reference flux as follows:

$$\omega sl=LmRr\psi r^*Lriqs^* \dots\dots\dots(9)$$

The synchronous reference frame speed is the sum of the angular slip speed and the angular rotor speed which can be given by

$$\omega e=\omega sl+\omega r \dots\dots\dots(10)$$

The unit vector is generated by integrating the synchronous frame reference speed as $\theta e=\omega e dt \dots\dots\dots(11)$

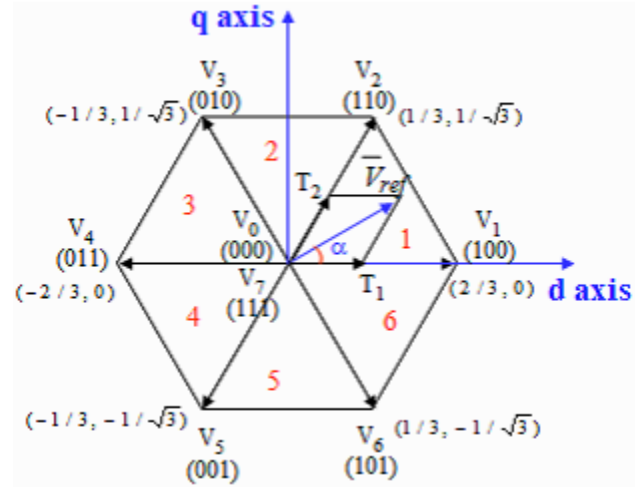

IV. THE CONTROL SCHEME

Fig. 1 explains the indirect field-oriented control system. The Clarke's transformation module receives the two phase currents, ia and ic. The transformation's results are referred to as asidssandiqss. These two current components serve as the Park transformation's inputs, which result in the current in the (d, q) rotating reference frame. The ids and iq s components are contrasted with the ids (the flux reference) and iq s (the torque reference) references. The rotor flux is fixed (decided by the magnets), therefore there is no need to

manufacture one, much like in synchronous permanent magnet motors. V_{ds} and V_{qs} , the outputs of the current controllers, are used to apply the inverse Park transformation. V_{dss} and V_{qss} , the components of the stator vector voltage in the stationary orthogonal reference frame, are the projection's outputs. These serve as the Space Vector PWM's inputs. Because of the well-known benefits of greater DC bus voltage consumption, fewer harmonic currents, and significant freedom in the placement of the space vector in a

sector through the selection of switching frequency, the Voltage Source Inverter employs the space vector pulse width modulation approach. The signals that power the inverter are the outputs of this block. In later parts, the Space Vector Pulse Width Modulation is thoroughly defined. It should be noted that the rotor angle, e , which is determined using equation (7), is required for both Park and inverse Park transformations.

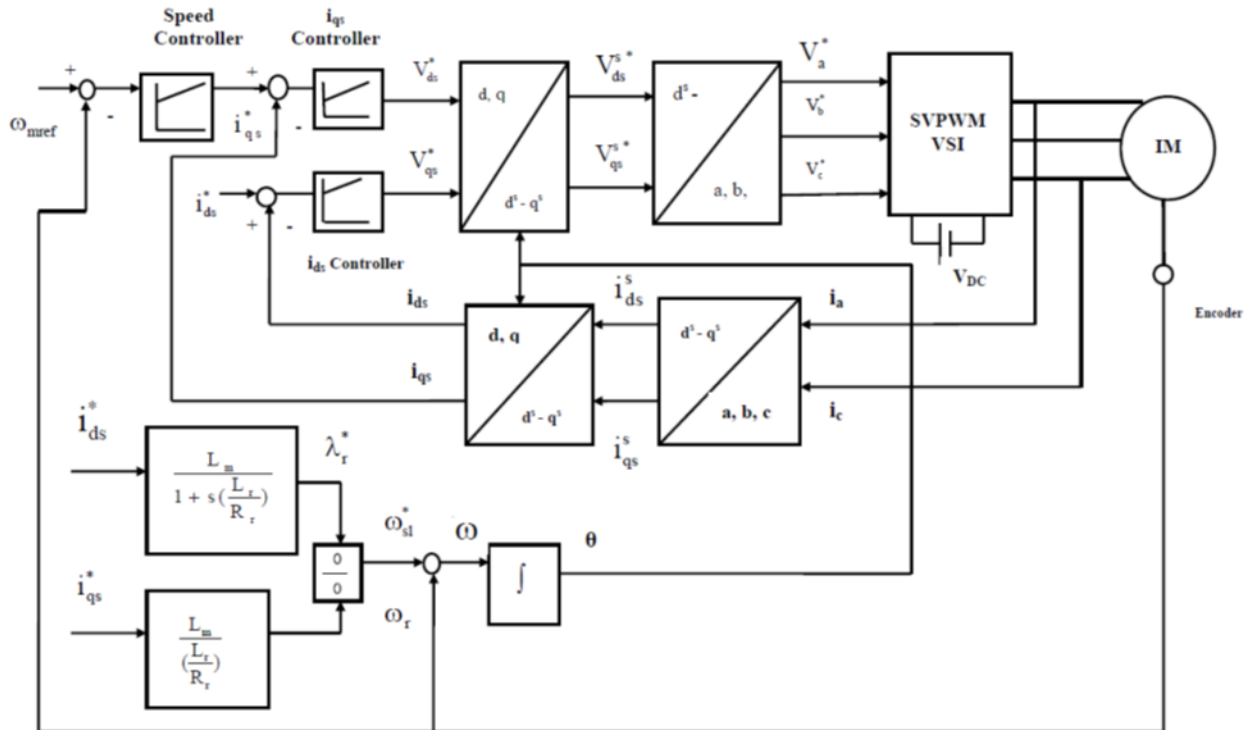

Fig. 1 Block diagram of Indirect Field Oriented Control (IFOC) scheme

V. SPACE VECTOR PULSE WIDTH MODULATION (SVPWM) TECHNIQUE

A three phase power inverter's top three power switches are switched in a certain order known as space vector PWM (SVPWM). In order to make better use of the DC link voltage, it produces less harmonic distortion in the output voltages and/or currents supplied to the phases of an AC motor. The voltage equations in the (a, b, c) reference frame are converted into the stationary (d, q) reference frame, which comprises of the horizontal (d) and vertical (q) axes, as illustrated in fig. 2, to execute the space vector PWM. There are eight possible mappings for the three control inputs (a, b, and c). Thus, two zero vectors and

six non-zero vectors are conceivable. The six nonzero vectors (V1-V6) that make up a hexagon's axis. Any two consecutive non-zero vectors have a 60 degree angle between them. The load is given zero voltage via the two zero vectors (V0 and V7), which are located at the origin. The fundamental space vectors, sometimes known as the eight vectors, are symbolized by the letters V0, V1, V2, V3, V4, V5, and V6. The intended reference voltage vector V_{ref} in the d-q plane may be obtained by applying the same transformation on the desired inverter output voltage. Utilizing the eight switching patterns, the space vector PWM approach aims to approximate the reference voltage vector V_{ref} . One simple method of approximation is to generate the average output of the inverter over a small period, T to

be equal to V_{ref} in the same period. The Space Vector PWM can be implemented by the following steps:
 Step 1: Determine V_d , V_q , V_{ref} and angle α
 $V_d = V_{an} - 12V_{bn} - 12V_{cn}$ $V_q = 32V_{bn} - 32V_{cn}$ $V_{ref} = V_d^2 + V_q^2$ $\alpha = \tan^{-1} V_q / V_d$
 Step 2: Determine time duration T_1 , T_2 and T_0
 $T_1 = T_z \cdot a \cdot \sin(\pi/3 - \alpha) \sin(\omega t)$
 $T_2 = T_z \cdot a \cdot \sin(\alpha) \sin(\omega t)$ $T_0 = T_z - (T_1 + T_2)$
 where $T_z = 1fs$ and $a = V_{ref} / 23V_{dc}$ Step 3: Determine the switching time of each transistor (S1 to S6)

VI. RESULTS

The specification of the induction motor and the control system is given in tables 1 and 2. The simulation of the indirect field-oriented control of the induction motor drive is modulated in MATLAB. The set values of speed and torque of the motor are maintained at 1500 rpm and 800 Nm in the simulation. As shown in fig. 4, the speed precisely follows the acceleration ramp until it achieves its set speed of 1500 rpm, which is observed to be achieved at 1.7 sec.

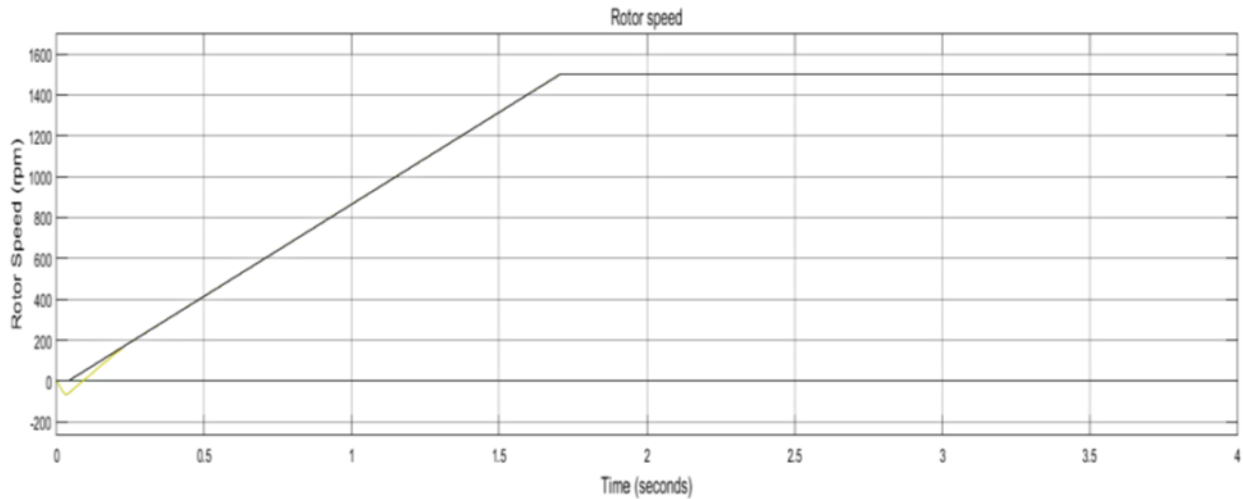

Fig. (4) Simulation results: Rotor speed

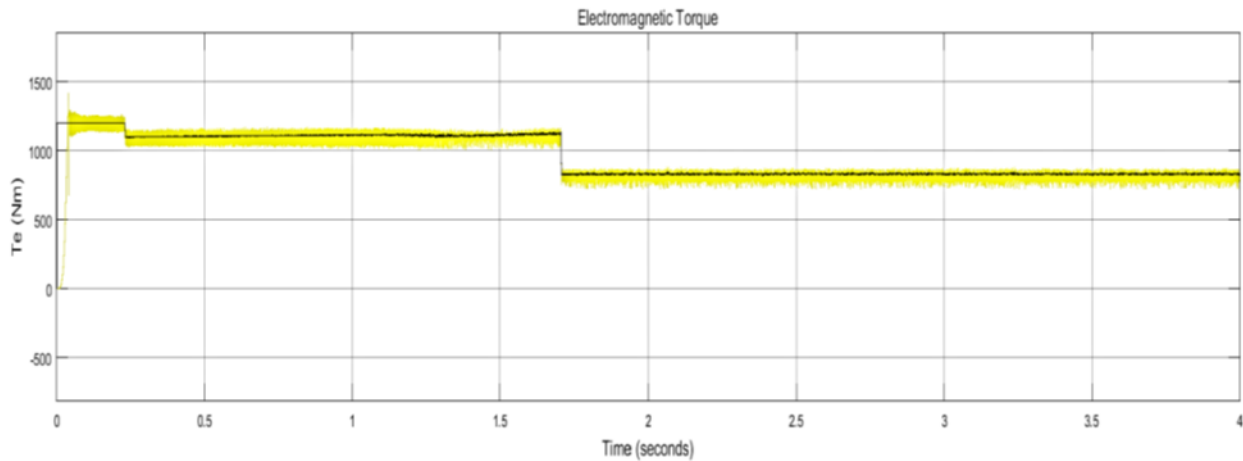

Fig. (5) Simulation results: Electromagnetic torque of induction motor

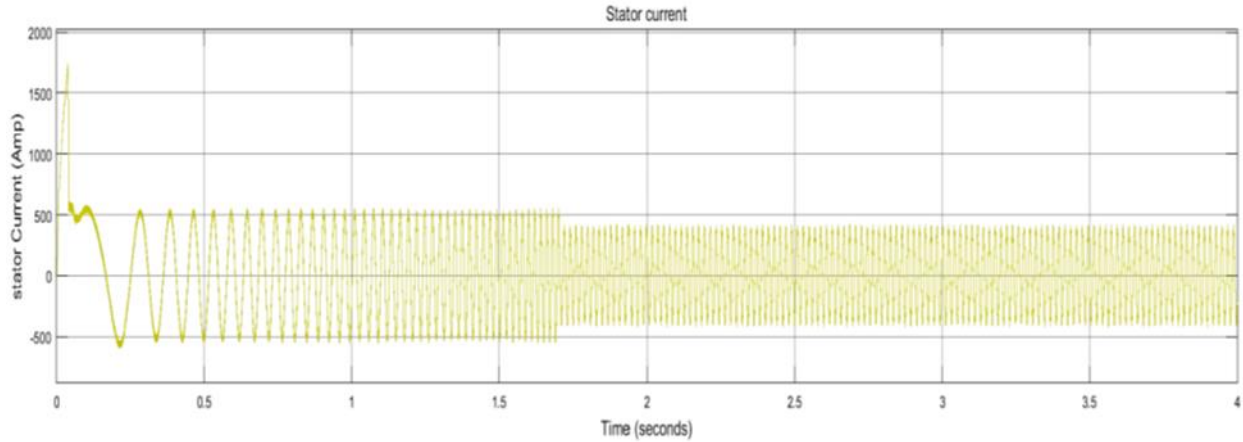

Fig. (6) Simulation results: Stator current of induction motor

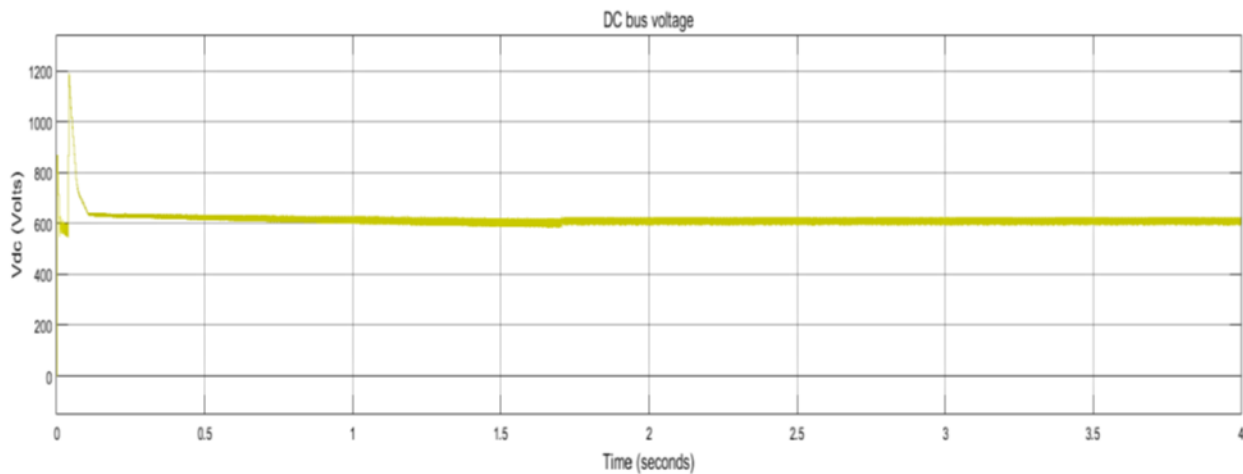

Fig. (7) Simulation results: DC bus voltage

VII. CONCLUSION

With the help of thorough block diagrams and mathematics, the fundamentals of the indirect field oriented control method used to achieve vector control of a cage induction motor are described. It demonstrates that the indirect field oriented control is an effective method for managing the induction machine without the need of sensors, hence lowering the complexity of the drive system. When a torque shift occurs, the induction machine reacts fast and precisely. The efficiency of IFOC employing SVPWM approach has been proven by the simulation results that were achieved. The speed and electromagnetic torque simulation results demonstrate that the induction machine's speed control is completed more quickly. Therefore, this system is appropriate for traction vehicle applications where dynamic reaction of the motor is required.

REFERENCES

1. Domenico Casade, Francesco Profum, Giovanni Serra, Angelo Tani, "FOC and DTC: Two Viable Schemes for Induction Motors Torque Control", IEEE TRANSACTIONS ON POWER ELECTRONICS, VOL. 17, NO. 5, SEPTEMBER 2002
2. Mircea Popescu, "INDUCTION MOTOR MODELLING FOR VECTOR CONTROL PURPOSE", Helsinki University of Technology, Laboratory of Electromechanics Report, Espoo 2000, 144 p.
3. Rakesh Singh Lodhi¹, Payal Thaku, "Performance & Comparison Analysis of Indirect Vector Control of Three Phase Induction Motor", International Journal of Emerging Technology and Advanced Engineering Volume 3, Issue 10, October 2013
4. Ashish Chourasia, Vishal Srivastava, Abhishek Choudhary and Sakshi Praliya, "Comparison study of

Vector Control of Induction Motor Using Rotor Flux Estimation by Two Different Method”, International Journal of Electronic and Electrical Engineering, Volume 7, Number 3 (2014), pp. 201-206

5. Muhammad H. Rashid, “Power Electronics, Circuits, Devices and Applications”, Third edition 2011

6.B.SrinuNaik,“ComparisonofDirectandIndirectVect or Control of Induction Motor”, International Journal of New Technologies in Science and Engineering Vol. 1, Issue. 1, Jan. 2014,

7. Bimal K Bose, “ Modern Power Electronics and AC Drives”, 2002,

8. VenuGopal B T “*Comparison Between Direct and Indirect Field Oriented Control of Induction Motor*”, International Journal of Engineering Trends and Technology (IJETT), Vol.-43, No.-6, January 2017

9. M.R.BaqheethaFathima, P.Magdelin Jennifer Princy, S. RamPrasath, “*Mathematical Modeling of SVPWM inverter fed 3 phase Induction Motor Vector control in MATLAB/Simulink Environment*”, International Conference on circuits Power and Computing Technologies [ICCPCT] 2017

10. SajiChacko, Dr. ChandrashekharN.Bhende, Dr. Shailendra Jain and Dr. R.K. Nema, “*Modeling And Simulation of Field Oriented Control Induction Motor Drive And Influence of Rotor Resistance Variations on Its Performance*” An International Journal (ELELIJ), Vol. 5, No. 1, February 2016

11. Vipul G. Pagrut, Ragini V. Meshram, Bharat N. Gupta, Pranao Walekar, “*Internal Model Control Approach To PI Tunning In Vector Control Of Induction Motor*”, International Journal Of EngineeringResearchand Technology (IJERT), Vol. 4 Issue 06, June-2015.

12. Nithin S. Nair, Anoop V.B., Arun V.A., JishnuChandran, SarathMenon C.S., “*Simulation of Indirect FOC Based 3-PhaseInduction Motor Drive*” International Journal of Advanced Research in Electrical, Electronics and Instrumentation Engineering Vol. 4, special issue-1, March 2015

13. K. Hemavathy, N. Pappa, S.Kumar, “*Comparison of Indirect Vector Control and Direct Torque Control Applied to Induction Motor Drive*”, IEEE International Conference on Advanced Communication Control and Computing Technologies (ICACCCT) 2014.

14. Azuwien Aida Boharia, WahyuMulyoUtomoa, ZainalAlamHarona, NooradzianieMuhd. Zina, Sy Yi Sim a, and Roslina Mat Ariff, “*Speed Tracking of*

Indirect Field Oriented Control Induction Motor using Neural Network” International Conference on Electrical Engineering and Informatics 2013 (ICEEI 2013)

15. Joachim Holtz, “*Sensorless Control of Induction Motor Drives*”, Proceedings of IEEE, Vol. 90, No. 8, August 2002