

Accident Detection and Alert System

Vijay Chauhan, Abhishek Mishra

Electronic and Communication Engineering, Rajkumar Goel Institute of Technology, Ghaziabad, Uttar Pradesh, India

Abstract—This electron Road accidents rates are very high nowadays, especially two wheelers. Timely medical aid can help in saving lives. This system aims to alert the nearby medical center about the accident to provide immediate medical aid. The attached accelerometer in the vehicle senses the tilt of the vehicle and the a heartbeat sensor on the user's body senses the abnormality of the heartbeat to understand the seriousness of the accident. Thus the systems will make the decision and sends the information to the smartphone, connected to the accelerometer through gsm and gps modules. The Android application in the mobile phone will send text messages to the nearest medical center and friends. Application also shares the exact location of the accident, and it can save time

Keywords— *Accident detection, alert system, GPS, GSM, Accelerometer, Android application.*

I. INTRODUCTION

Nowadays, the rate of accidents has increased rapidly. Due to employment, the usage of vehicles like cars, bikes have increased, because of this reason the accidents can happen due to over speed. People are going under risk because of their over speed, due to unavailability of advanced techniques, the rate of accidents can't be decreased. To reduce the accident rate in the country this paper introduces a solution. Automatic accident detection and alert systems are introduced. The main objective is to control the accidents by sending a message to the registered mobile, hospital and police station using wireless communications techniques. When an accident occurs in a city or any place, the message is sent to the registered mobile through GSM module in less time. Arduino is the heart of the system which helps in transferring the message to different devices in the system. Vibration sensor will be activated when the accident occurs and the information is transferred to the registered number through the GSM module. The GPS system will help in finding the location of the accident

spot. The proposed system will check whether an accident has occurred and notify nearest medical centers and registered mobile numbers about the place of accident using GSM and GPS modules. The location can be sent through a tracking system to cover the geographical coordinates over the area. The accident can be detected by a vibration sensor which is used as a major module in the system.

II. OBJECTIVES AND SCOPE

The main objective of this project is to prevent casualties which happen due to lack of medical assistance in time. Certainly, if the accident happens due to other cases, the used electronic devices will be able to provide the spontaneous message and exact location to police and ambulance in order to recover victims. Avoiding casualties caused by road accidents is the main goal of this paper, with the help of Accelerometer and GPS present in the mobile phones. Based on the data collected from these sensors, which are present in most mobile phones, the location of the accident is sent at the same time of the accident to the friends and relatives which the user allowed and stored and also to the rescue and emergency services.

III. EXISTING SYSTEM

This idea proposal has been introduced at the start of the modern age of mobile phones. With the introduction of GPS sensors in the mobile, security applications based on GPS were proposed. Then they proposed special hardware devices which can be linked with mobile phones. Though, it had the disadvantage of actually buying extra hardware with more money. With the massive development of mobile phones in the last decade and new sensors added with the development, the extra hardware can be avoided. The present application of this paper is present in a very few countries and providing the information with the relatives and friends with the emergency services the

efficiency of the application can be increased massively.

Drawbacks of the Existing System:

The live system can't work if any of the following occur at the time of the crash:

- Automatic or phone is disconnected or damaged.
- No GPS signal at the time of the crash.
- Insufficient cellular signal to upload crash details

IV. PROBLEM STATEMENT

The use of vehicles increases in the proportion of the population. Due to the traffic congestion, the accidents are also increasing day by day. This causes the loss of life due to the delay in the arrival of ambulances to the accident spot or from the accident spot to the hospital. So, it is necessary to take the accident victim to the hospital as soon as possible. Whenever an accident occurs, it has to be informed to the investigation unit. So, it is also beneficial if the intimation is reached to the enquiry section so that the time for the investigation can be minimized.

V. PROPOSED METHOD

The main idea of this paper is to build an application that makes use of the sensors present in mobile phones like GPS and Accelerometer and detect any collision if there is a sudden external disturbance in the speed with the help of the Sensor Fusion Based Algorithm. With the help of the data obtained from the Accelerometer sensor, when there is a sudden disturbance to the mobile phone, the user is notified with an alert message before sending the request help signal. If no emergency is required, they can cancel it within 10 seconds. But, if they press the "Call Help" button or if the alert message is unattended for more than 10 seconds, the "request for help" message will be sent to the emergency services as well as the family members, the users provided.

VI. SYSTEM ARCHITECTURE

In this system, the external disturbance is detected by the accident detection module and when it is detected, a function is called to find the current location of the user with the help of GPS in the Location Detection

Module. The location data obtained from the GPS is sent to the emergency services to request help.

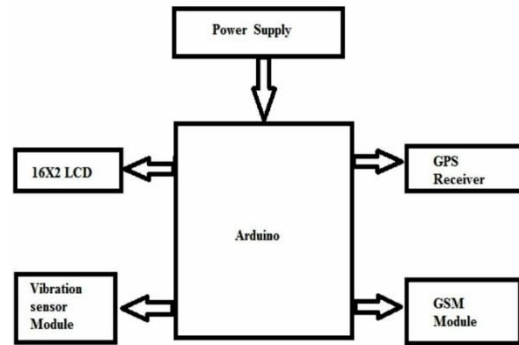

Fig 1: Arduino System

The vehicle unit consists of an accelerometer which keeps on informing the coordinate of vehicle position to the microcontroller. If it is found at random, the GPS location tracker tracks and informs the emergency number with values of latitude, longitude and google map position using the GSM SIM module.

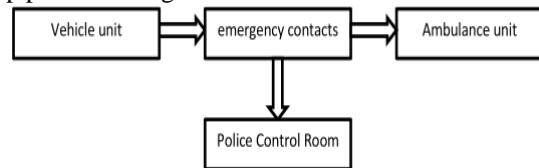

Fig 2: Vehicle Unit Service System

Vehicle unit sends the information to the emergency contacts like police control room and an ambulance unit.

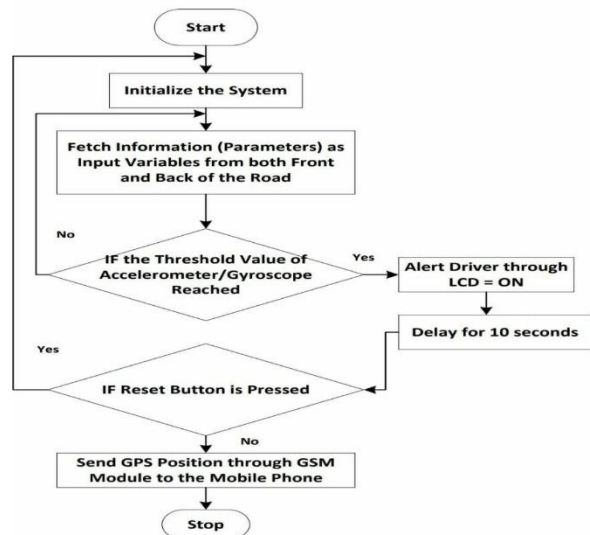

Fig 3: Accident detection alert System

In this system at first, we worked on the prevention of vehicle accident and even after all the preventive measures applied if the accident occurs the system detects it. After the detection of vehicle accident, the

system automatically reports to the ambulance service and police station without any time loss so that the casualty might not loss his/her life due to lack of medical assistance in time. The system is installed in the vehicle. For the detection of vehicle accidents accelerometers are installed and for reporting, GPS module and GSM module are used. Motor (control switch) is used for engine control and buzzer, led lights etc. are used for warning during prevention. All these devices are interfaced with the central microcontroller (Arduino Uno) unit.

Accelerometer detects the occurrence of accident and sends signal to the microcontroller for further functioning. The GPS module provides the location, speed, time and date of the certain place where the vehicle is in the real time. If an accident occurs, the accelerometer detects it and location of accident is obtained using GPS, and finally sends the information to the ambulance service and police by the help of a GSM module. The message obtained in mobile phone consists of the location of the accidental place in the form of google map link which will help the emergency units like ambulance service and police station to reach the casualty in time and rescue the lives/

1. The Arduino setup is installed in a vehicle's crash guard or in bumpers of the vehicle on each side.
2. When collision occurs it triggers the push button and it sends a notification to the Arduino Board.
3. Arduino will take this input and will convert to the SIM808.
4. The coordinates are shared through GSM.
5. Through GSM the notification is passed to the saved mobile number.
6. It contains the exact GPS location.
7. The application is used to know the route and location.
8. If the accident is not severe the person can turn off the buzzer and the device will come back to normal.

VII. MODULES AND PROJECT DESCRIPTION

ARDUINO: The Arduino UNO is a widely used open-source microcontroller board based on the ATmega328P microcontroller and developed by Arduino.cc. The arduino is the major control unit to detect or alert when an accident occurs. It collects the data from vibration sensors, GPRS and GSM modules

and reflects the output either in display system or through a message. Here the vibration sensor plays a major role. This vibration sensor will receive the vibrations of the vehicle which in turn acts as an accident detection module. Arduino gathers the information from all other modules and sends the message to the receiver through the GSM module.

GPS MODULE: To find the location on the earth the whole is divided into some coordinates where the location can be easily captured by a module called GPS module. Here the GPS used is SIM28ML. This GPS module will find the location of the vehicle and the information fetched by the GPS receiver is received through the coordinates and the received data is first send to arduino and the information is transmitted to the saved contact through GSM module. The frequency is operated in the range of 1575.42 MHz and the output of the GPS module is in NMEA format which includes data like location in real time

GSM MODULE: For providing communication between the GPS, GSM and the allocated mobile number GSM SIM900 module is preferred. The name SIM900 says that, it is a tri band work ranging a frequency of 900MHz to 1900 MHz such as EGSM900 MHz, PCS 1900 MHz and DSC 100 MHz Receiving pin of GSM module and transmitting pin of GPS module are used for communication between the modules.

LCD MODULE: To display the numbers, alphabets and special characters an LCD module with 16x2 alphanumeric types is used. Using the higher bit data lines of LCD pins such as pin 11,12,13 and 14 are interfaced to digital pins of Arduino such as pin 8,9,10 in 4 bit mode as shown in the below figure. RS and E pins of LCD are connected to pin 12 and 13. To perform the write operation on LCD the read/write pin is connected to ground.

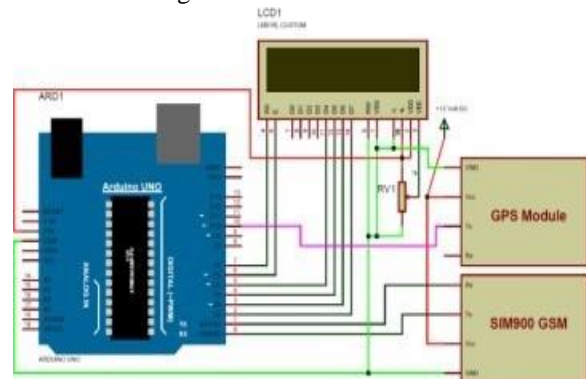

Fig 4: Working module of accident detection and alert system

The controller used in this project is Arduino which is used for controlling all the modules in the circuit. The two major parts other than the controller is the GPS module which is used as a receiver and other module is GSM. To receive the coordinates of the vehicle GPS module is used and GSM will send the received coordinates to the user through SMS. There is an additional LCD which is used for displaying status message or coordinates. When a person is driving the vehicle met with an accident then the vibrations of the vehicle is received by the vibration sensor and the sensor acts as a accident detection module which further send the information to the micro controller and the location of the vehicle is received through GPS module and the coordinates The vehicle is sent to the GSM module. The received information is sent to Arduino uno. The received coordinate information is collected and is sent to the respected person hospitals and police station through SMS.

Implementation

Our system comprises two phases: accident detection and notification phase. For the accident detection phase, a smartphone application has been fully implemented. For the notification phase, a web-based system has been implemented for use by hospitals.

Detection Phase Implementation:

An Android application has been developed in the Java programming language. The application is developed for an Android operating system with minimum API level 17 and target API level 26. A user first registers for system use. Once registered, to use the system, the user enters their ID and password to log in to the system. Recording and transmission of data starts when the user clicks to start tracking. The application continually reads the data from the smartphone’s sensors and sends the data to the cloud. If an accident is identified, the application generates an alarm for 10 s. Figure below shows the interfaces of smartphone android applications. The smartphone application consists of the following activities:

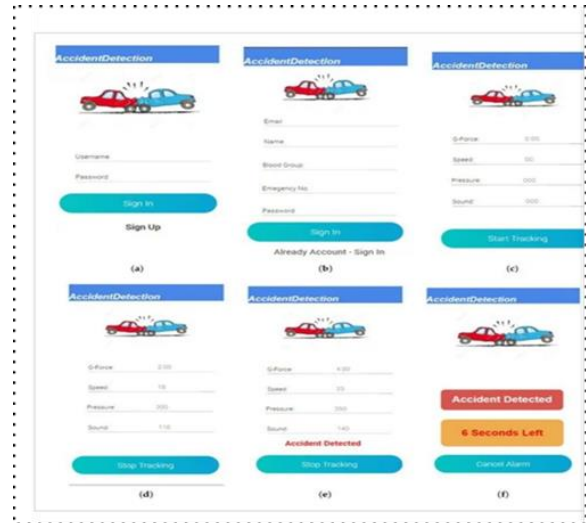

Fig 5: Android Application (a) Sign In Screen; (b) Sign Up Screen; (c) Start Tracking; (d) No Accident; (e) Accident Detected; (f) Alarm

1. Start and Stop Accident Detection Activity
2. Tracking of Accidents.
3. Cancellation of Alarm.
4. Management of Account.

Notification Phase Implementation:

After an accident is identified, the cloud determines the nearest hospital and informs the hospital about the accident. This is performed using a web-based application. The application has been developed using ASP .NET MVC 4. This interface is used by the hospital to establish whether there is an emergency or not. Whenever an accident occurs, the website receives the information regarding the accident. The website shows the details of the accident such as the location of the accident and driver and vehicle information. A Microsoft SQL database is used to store all the information regarding an accident. The website uses HTML, CSS and bootstrap for the development of the interfaces. The Google Maps API is used to show the position of the accident on a map. Figure below shows the working of web based application.

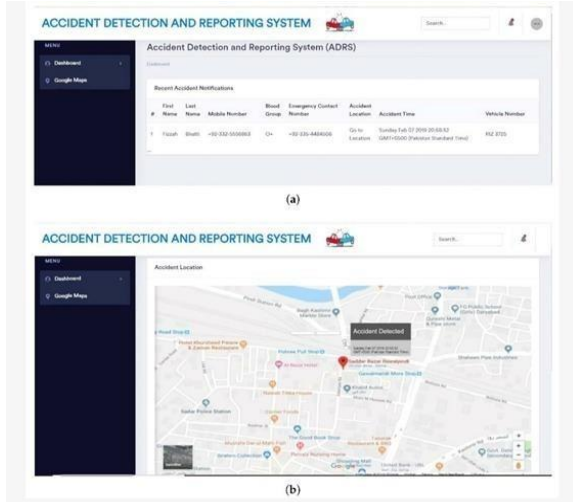

Fig 6:(a) Accident details; (b) Location of the Accident

RESULTS

The overall result of this project is an application that provides help to people who require help but can't ask for it. With the help of the application, their request for help is sent at the time of the accident with their location which helps emergency services provide support as early and effective as possible. All this is done with only the sensors available at low cost.

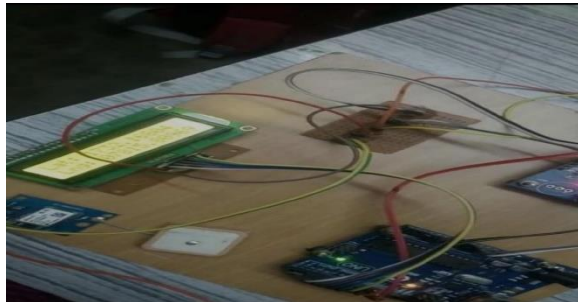

Fig 7: Interfacing controller with LCD

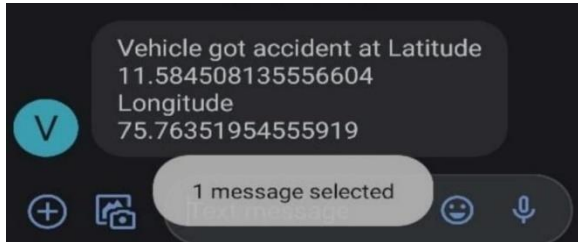

Fig 8: Notification message

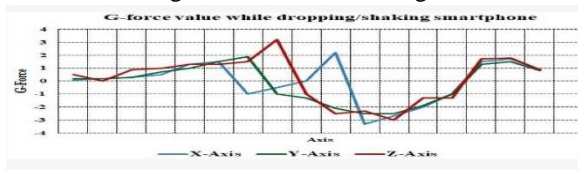

Fig 9: Experimental Graph

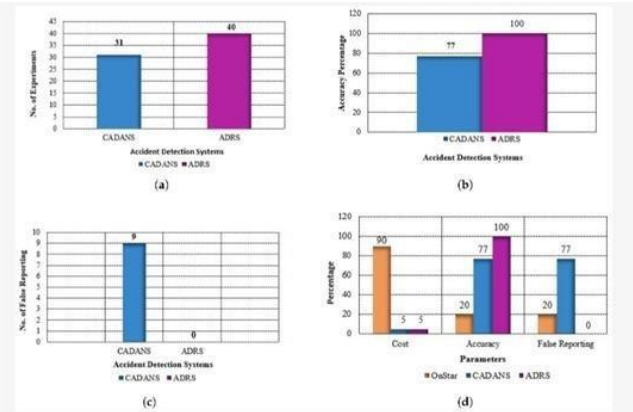

Fig 10: Experiment results. (a) comparison of accident detected; (b) accuracy percentage of experiments; (c) false reporting of experiments; (d) parameter-based comparison.

VIII. CONCLUSION

The proposed programmed accident detection system can be a rescuer of life for the people who met with accidents. The proposed system is exceptionally easy to understand and even a non-specialized Person can use it without any problem. The system consists of equipment and programming segments. The equipment unit includes accident detection sensors that are constrained by an Arduino board and is fitted in the vehicle.

Then again, the programming part is an Android application introduced in drivers Smartphones which is used to get the point by point map. In general, the benefits of this system are low cost, secure and simple to use. The system introduced in this work reduces the casualties due to accidents.

IX. REFERENCES

[1] DR.C.K.Gomathy , V.Geetha , S.Madhumitha , S.Sangeetha , R.Vishnupriya Article: A Secure With Efficient Data Transaction In Cloud Service, Published by International Journal of Advanced Research in Computer Engineering & Technology (IJARCET) Volume 5 Issue 4, March 2016, ISSN: 2278 – 1323.

[2] Dr.C.K.Gomathy,C K Hemalatha, Article: A Study On Employee Safety And Health Management International Research Journal Of Engineering And Technology (Irjet)-Volume: 08 Issue: 04 | Apr 2021

- [3] Dr.C K Gomathy, Article: A Study on the Effect of Digital Literacy and information Management, IAETSD Journal For Advanced Research In Applied Sciences, Volume 7 Issue 3, P.No-51-57, ISSN NO: 2279-543X,Mar/2018
- [4] Dr.C K Gomathy, Article: An Effective Innovation Technology In Enhancing Teaching And Learning Of Knowledge Using Ict Methods, International Journal Of Contemporary Research In Computer Science And Technology (Ijcrct) E-Issn: 2395-5325 Volume3,Issue 4,P.No-10-13, April '2017
- [5] Dr.C K Gomathy, Article: Supply chain-Impact of importance and Technology in Software Release Management, International Journal of Scientific Research in Computer Science Engineering and Information Technology (IJSRCSEIT) Volume 3 | Issue 6 | ISSN : 2456-3307, P.No:1-4, July-2018.
- [6] C K Gomathy and V Geetha. Article: A Real Time Analysis of Service based using Mobile Phone Controlled Vehicle using DTMF for Accident Prevention. International Journal of Computer Applications 138(2):11-13, March 2016. Published by Foundation of Computer Science (FCS), NY, USA,ISSN No: 0975-8887
- [7] C K Gomathy and V Geetha. Article: Evaluation on Ethernet based Passive Optical Network Service Enhancement through Splitting of Architecture. International Journal of Computer Applications 138(2):14-17, March 2016. Published by Foundation of Computer Science (FCS), NY, USA, ISSN No: 0975-8887
- [8] C.K.Gomathy and Dr.S.Rajalakshmi.(2014), "A Software Design Pattern for Bank Service Oriented Architecture", International Journal of Advanced Research in Computer Engineering and Technology(IJARCET), Volume 3,Issue IV, April 2014,P.No:1302- 1306, ,ISSN:2278-1323.
- [9] C. K. Gomathy and S. Rajalakshmi, "A software quality metric performance of professional management in service oriented architecture," Second International Conference on Current Trends in Engineering and Technology - ICCTET 2014, 2014, pp. 41-47, doi: 10.1109/ICCTET.2014.6966260.