

Disposable Service System for Sustainable Development

Prabhu D, Priyanka R, Vishwanath K, Harson M

Assistant Professor, Computer Science and Business Systems, Sri Sairam Engineering College, Chennai, Tamil Nadu, India.

UG student, Computer Science and Business Systems, Sri Sairam Engineering College, Chennai, Tamil Nadu, India

Abstract—The escalating issues of waste generation and management, particularly concerning urban dwellers' attitudes, are critically examined in this paper. Through the administration of 150 questionnaires, insights into waste classes, disposal frequency, and evacuation methods were gathered. To tackle this, we propose an automated waste segregator using ATmega328/Arduino, sorting waste into metal, plastic, and organic categories. This innovation minimizes manual labor and time, enhancing efficiency at treatment plants. A user-friendly website aids waste collection, while specialized dumpsters streamline gathering. Post-collection, the system optimizes resource usage and promotes environmental sustainability. Our goal is to revolutionize waste management, emphasizing recycling and societal benefits.

Keywords: Automation, Environment, Waste Segregation, Sensors, ATmega328/Arduino, Recycling

I. INTRODUCTION

Human activities always generate waste. This was not a major issue when the human population was relatively small but became a serious problem with urbanization and the growth of large contributions. Poor management of waste led to contamination of water, soil and atmosphere and to a major impact on Public health. The characteristics of waste material evolved in line with changes In lifestyle and the number of new chemical substances present in the various Waste streams increased dramatically.

The long-term health effects of exposure To substance present in the waste or produced at waste disposal facilities are more difficult to measure, especially when their concentrations are very small and when there are other exposure pathways.

Waste management and disposal is an alarming problem encountered by many of the urban and industrial areas in developing economics in Asian

countries. Waste generation has witnessed an increasing trend parallel to the development of industrialization, urbanization, and rapid growth of population.

Problem Statement: In a world facing mounting environmental challenges, waste management has emerged as a critical issue. With urbanization and industrialization on the rise, traditional disposal methods like landfills and incineration are proving unsustainable. It's time for a new approach. Sustainable waste management, rooted in the principles of the circular economy, offers a solution. By rethinking how we use and dispose of resources, we can create a cleaner, healthier future for generations to come.

Objective of the Project: Creating an automated garbage sorting System that can classify waste into three categories: Metal Waste, Plastic Waste and Organic Waste. The System aims to promote recycling and reduce the environment impact of improper waste disposal.

DESIGN METHODOLOGY: The Automated garbage sorting system will classify the waste into three categories and for collecting waste we using website to allow a waste producer to request a waste collection service and we use it to manage all aspects of waste management will be the one of the best ways to reduce the amount of solid waste. The application that we are going to develop will have the following module.

Software Modules are as follows:

- **USER AUTHENTICATION:**

The user must provide valid login credentials to access the system.

● **USER ROLES:**

Based on the login credentials, the system should identify the user’s role (admin, driver, buyer, distributor) and show relevant features.

● **WASTE PURCHASE:**

The buyer can purchase the waste required by them through the system. The system should allow them to select the type of waste and the quality.

● **DUMPSTER RENTAL:**

The user can rent a dumpster based on their needs. The system should allow them to select the dumpster size and duration of rental.

● **ROUTE OPTIMIZATION:**

The system should optimize the routes for garbage collectors and distributors to efficiency collect and distribute the waste.

● **DATA STORAGE:**

All the data related to waste purchase, dumpster rental, garbage collection, and distribution should be stored in a database for future reference.

● **SYSTEM MAINTENANCE:**

The system should provide maintenance features to ensure the efficient functioning of the garbage management system. This can include features like monitoring dumpster fill levels and scheduling dumpster pickups.

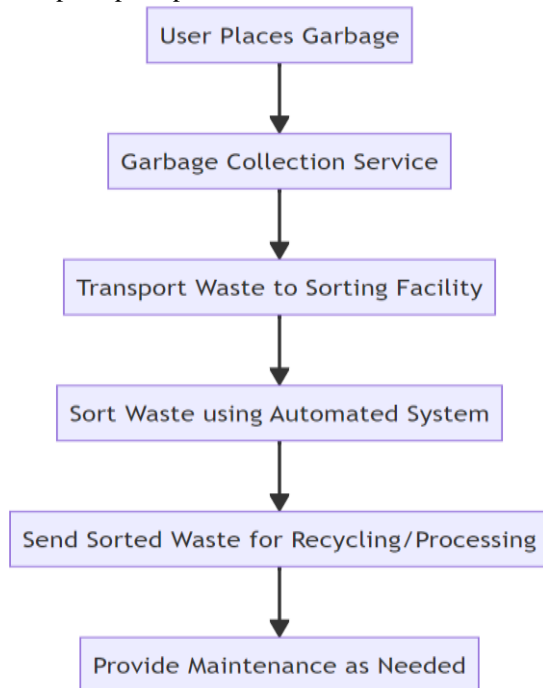

1.1 System Architecture

Hardware Modules are as follows:

● **SENSOR MODULES:**

- Metal Sensor: Detects the presence of metallic objects in the waste.
- Plastic Sensor: Identifies plastic materials based on certain characteristics.
- Organic Sensor: Uses specific sensors to recognize organic waste.

● **ACTUATION MECHANISM:**

- Servo Motors: Used to control gates or chutes that direct the sorted waste into the respective bins.
- Conveyor Belt: Transports the waste items to the sorting area

● **CONTROL UNIT:**

- Microcontroller (eg., Arduino): Manages the entire system and processes sensor data.
- Programming: Develop a program to analyze sensor inputs and control the actuators accordingly..

● **USER INTERFACE:**

- LCD Display: Provides real-time information on the sorting process and system status.
- LED Indicators: Signal the status of each waste category.

II. METHODOLOGY

A. EXISTING SYSTEM: Waste accumulation and disposing become main problem facing populated cities, due to the way of managing the waste containers. The recent technologies provide radical solution and effective way to handle these problems.

In this work wireless sensor network (WSN) and internet of things (IOT) technologies are used to manage the usage of the waste containers. This paper presents real time monitoring of the container contents using sensors, displaying the result in the website and the sensed contents are analyzed to determine the optimized distribution of the containers.

Waste bin monitoring technology using global system of mobile. The precise identification of location on the earth surface can be easily providing by global positioning system as it works by

measuring distance from satellite. In this technology, sensors are placed in public garbage bins to detect a certain optimum level of waste.

The location of dustbin is provided by global positioning system and when the dustbins 90% filled, the message is forward to concerned authority by GSM. As the garbage reaches the threshold level, indication will be transferred to the controller which will further give indication to driver of the truck by sending SMS using GSM for emptying the bin urgently

B. PROPOSED SYSTEM:

The proposed solution involves the implementation of an advanced automated garbage sorting system. This cutting-edge system classifies waste into three distinct categories: Metal, Plastic, and Organic. By leveraging this technology, we aim to revolutionize waste management practices, enhancing recycling efforts and significantly reducing environmental impact.

To streamline waste collection, we have developed a user-friendly website that allows for easy scheduling of pickups. Additionally, specialized dumpsters have been introduced to facilitate efficient waste collection. Post-collection, our automated sorting system optimizes resource utilization, ensuring that materials are efficiently processed and recycled. Through this comprehensive approach, we are committed to promoting environmental sustainability and driving positive change in waste management practices.

1.2 Circuit Diagram

- Sensing and Sorting: As items move along the conveyor belt, the metal, plastic, and organic sensors analyze the characteristics of each item. The microcontroller processes the sensor data and determines material type
- Actuation: Depending on the material type, the microcontroller activates the corresponding actuator (e.g., servo motor) to redirect the item to the appropriate bin
- Display and Feedback: The LCD display shows real-time information about the sorting process. LED indicators signal the successful sorting of each waste category.
- End of Sorting: The System continues to

operate until all items have been sorted. The user can then retrieve the sorted waste from the designated bins.

WASTE COLLECTION PROCESS: There are several ways to collect waste they are stated below:

- House-to-House: Waste collectors visit each house to collect garbage. Generally, the user has to pay a fee for this service.
- Community Bins: Users bring their garbage to community bins that are placed at fixed points in a neighborhood or locality. Waste is picked up by the municipality, or it's designate, according to a set schedule.
- Curbside Pick-up: Users leave their garbage directly outside their homes according to a garbage pick-up schedule set with the local authorities.
- Self-Delivered: Generators deliver the waste directly to disposal sites or transfer stations, or hire third-party operators.
- Contracted or Delegated Service: Business hire firms who arrange collection schedules and charge with.

BENEFITS:

- Efficient Sorting: Automates the waste sorting process, improving efficiency and accuracy.
- Environmentally Friendly: Encourages recycling by facilitating the separation of recycling materials.
- Educational: Raises awareness about proper waste disposal and recycling practices.

III. PROTOTYPE DEVELOPED

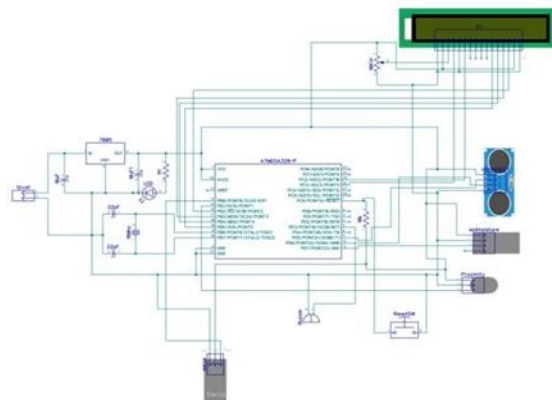

1.3 Website



1.4 Hardware

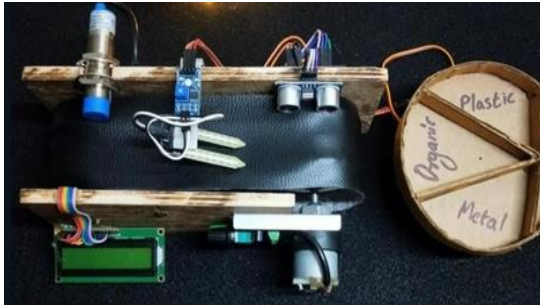

IV. CONCLUSION AND SCOPE

The global waste management approaches in addressing waste management challenges. By implementing an advanced automated garbage sorting system, we are breaking new ground in the field. This system's capability to classify waste into Metal, Plastic, and Organic categories sets it apart from traditional methods, offering a more efficient and precise solution. Furthermore, the website is user-friendly and specialized dumpsters represent innovative additions to waste collection infrastructure, enhancing accessibility and effectiveness. The optimization of resource utilization through our automated sorting system demonstrates our commitment to maximizing efficiency and sustainability. In essence, the unique combination of technology, convenience, and environmental consciousness positions at the forefront of progressive waste management solutions, paving the way for a cleaner and more sustainable future.

REFERENCE

[1] P Ramesh, J Martin Sahayaraj, N Subash, S R Mugunthan, S Jaya Pratha "IoT based Waste Management System" Electronics and

Renewable Systems (ICEARS), International Conference on 2022 IEEE Paper.

- [2] R Geethamani, P Rakshana, P Raveena, R Ragavi. "Garbage Management System." International Conference on Advanced Computing and Communication Systems (ICACCS) IEEE Paper 2021.
- [3] bh. Srinivas Sasikanth, Lingamsetty Naga Yoshita, G Narasimha Reddy, Manitha P.V. "An Efficient & Smart Waste Management System." Computational Intelligence and Computing Applications (ICCICA), International Conference on 2021 IEEE Paper.
- [4] Gabriela Zirna, Daniela Saru, Stefan Mocanu "Sustainable Waste Management System." International Symposium on Advanced Topics in Electrical Engineering (ATEE) IEEE Paper 2021
- [5] S Sreejith, R Ramya, R Roja, A Sanjay Kumar "Smart Bin For Waste Management System" International Conference on Advanced Computing and Communication Systems (ICACCS) IEEE Paper 2019.
- [6] Shyam G K, Manvi S.S, Bharti P "Smart Waste Management using IOT" International conference on Computing and Communications Technologies 2017
- [7] Clearance system using internet of things." IEEE Smart Technologies and Management for Computing, Communication, Controls, Energy and Materials, (2017).
- [8] Shymala S C, Kunjan Sindhe, Vishwanth muddy, Chithra "Smart Waste Management System" 2016
- [9] Koushal V, Sharma R, Sharma M, Plastics: issues challenge and remediation 2016.
- [10] Kurre, Vishesh Kumar. "Smart Garbage Collection Bin overflows Indicator using IOT." International Research Journal of Engineering and Technology (IRJET) (2016).
- [11] Vu, Dung, and Georges Kaddoum. "A waste city management system for smart cities applications." (2017).2017 Advances in Wireless and Optical Communications
- [12] Foliato, Fachmin, Yong Sheng Low, and Wai Leong Yeow. "Smartbin: Smart waste management system." Tenth IEEE International conference on Intelligent Sensors, Sensor Networks and Information Processing (ISSNIP),

(2015).

- [13] S Sreejith, R Ramya, R Roja, A Sanjay Kumar
“Smart Bin For Waste Management System”
International Conference on Advanced
Computing and Communication Systems
(ICACCS) IEEE Paper 2019.
- [14] Shyam G K, Manvi S.S, Bharti P “Smart Waste
Management using IOT” International
conference on Computing and Communications
Technologies 2017
- [15] Clearance system using internet of things."
IEEE Smart Technologies and Management for
Computing, Communication, Controls, Energy
and Materials, (2017).