

Soft-Switching Secondary-Side Modulated Multiple-output DC/DC Converter

M.J. Murali

Department of Electrical and Electronics Engineering, Bharath Institute of Higher Education and Research, Chennai, Tamil Nadu

Abstract- The aim of this study is to develop a closed loop single-input multiple-output (SIMO) dc-dc converter. Multiple output converters (MOCs) are widely used for applications which require various levels of the output voltages due to their benefits in cost, volume, and efficiency. However, most of the MOCs developed so far can regulate only one output tightly and require as many secondary windings in the transformer as the number of the outputs. In this paper, Space Vector Pulse Width Modulation method to regulate all the outputs in high precision is proposed and applied for the multiple output battery charger based on the phase shift full bridge topology to charge a multiple number of batteries at one time. The proposed system is characterized by good dynamic properties and high efficiency because the converter transistors are switched in ZVS conditions. A theoretical analysis to provide relations for system design, and the laboratory model investigations to validate the system characteristic is given in the paper.

Index terms- Multiple output battery charger, Phase shift full bridge, and ZVS-ZCS

I.INTRODUCTION

DC-DC power converters are employed in a variety of applications, including power supplies for personal computers, office equipments, spacecraft power systems, laptop computers, and telecommunication equipments, as well as DC motor drives. Significant progress in the fields of circuit topologies, semiconductor power devices, control theory, advances in integrated electronics have greatly reduced the size of many electronic systems. In order to utilize the advantages of compact denser electronics, power densities (output power per unit volume) that are much higher than what is possible with present DC-DC power converters are demanded. Based on the system requirements such as output to input voltage relationship, power rating, and the need of galvanic isolation, there are various types of DC to DC converter topologies. Based on the electrical isolation requirement

DC-DC converters can be classified as isolated and non-isolated converters. Step-down (Buck) converters and step-up (Boost) converters are the basic topologies. The other topologies can be derived from these two converters. In hard switching during the turn-on and turn-off processes, the power device has to withstand high voltage and current, resulting in high switching losses and stress. By adding dissipative passive snubbers to the power circuits the dv/dt and di/dt of the power devices can be reduced. The maximum switching frequency of the power converters are limited (typically 20 kHz to 50 kHz), since the switching loss is proportional to the switching frequency. The electromagnetic interference (EMI) is due to transient ringing effect.

In order to obtain good efficiency at high switching frequency, lossless switching is to be achieved. Soft switching techniques are used to achieve loss-less switching. Soft switching is obtained by adding resonant components (inductors and capacitors) or using the parasitic components of a DC-DC converter. Soft switching of a controllable switch can be provided by using either Zero current switching (ZCS) or Zero voltage switching (ZVS) technique. The resonant converters have resonant tanks to create oscillatory voltage and/or current waveforms so that zero voltage switching (ZVS) or zero current switching (ZCS) conditions can be created for the power switches. The switching losses are reduced, hence the switching frequency can be increased (typically 100 kHz to 500 kHz). Since the magnetic sizes are reduced, the power density of the converters can be increased. The resonant current and voltage of resonant converters have high peak values, compared to PWM converters, leading to higher conduction loss.

New soft-switched converters combine the advantages of PWM converters and resonant converters. These soft-switched converters have switching waveforms similar to PWM converters but their rising and falling edges of the waveforms are „smoothed“ without transient spikes. Resonance is allowed to occur just before and during the

turn-on and turn-off processes so as to create ZVS and ZCS conditions. Other than that, they behave just like conventional PWM converters. Because the switching loss and stress have been reduced, soft-switched converter can be operated at very high frequency (typically 500 kHz to a few Mega-Hertz). EMI is suppressed. Various forms of soft-switching techniques are ZVS, ZCS, voltage clamping, zero transition methods etc.

A resonant switch is a sub-circuit comprising a semiconductor switch S and resonant elements, L_r and C_r . The switch S can be implemented by a unidirectional or bidirectional switch, which determines the operation mode of the resonant switch

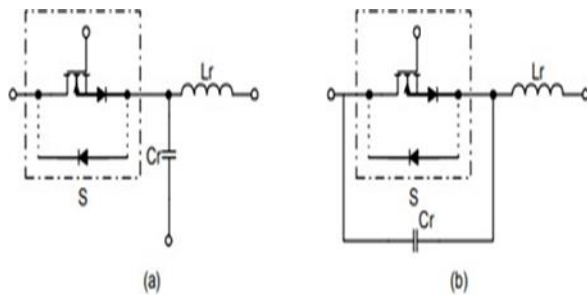

Figure 1. Zero-voltage (ZV) resonant switch

II. RELATED WORK

The present direction of evolution in DC to DC converters is towards higher efficiency and higher power density. Both can be achieved by higher switching frequency and low overall losses. Soft switching results in zero switching losses and increases the switching frequency to 100 kHz and above. Soft switching techniques are developed to reduce switching losses and electromagnetic interference (EMI). During soft switching, switching frequency can be increased to enhance the converter power density.

In zero current switching, an inductor is placed in series with converter main switch or main diode. During turn on soft switching condition is provided by the inductor. Before switch turn off, an auxiliary switch is turned on and the main switch current is reduced to zero. (Wang 2008 Das and Moschopoulos 2007) In the research work carried out by (Jung et al 1996) Zero-voltage and zero-current switching full-bridge PWM converter using secondary active clamp, the harmonics can easily be eliminated by power filter and it has a capability in allowing continuous and linear control of the frequency and fundamental component of the output voltage.

But with the demands for higher power densities, the switching frequencies are approaching 1 MHz range.

(Zhang et al 2006, Song and Huang 2005, Kim and Kim 2002, Seok and Kwon 2001) Increasing the frequency of operation of power converters is desirable as it allows the reduction in size of the circuit magnetics and capacitors, hence leading to cheaper and more compact circuits. However increasing the frequency of operation also increases the switching losses and hence reduces the system efficiency. At high frequencies, square wave converter's switching losses become very high leading to excessive heat dissipation. Even if the increased switching frequency does not cause unacceptable switching losses, the oscillations caused by converter parasitic elements may cause high current and voltage stresses, which are almost unpredictable, depending on circuit lay out (Sabate et al 1990, Borage et al 2005).

In the research work carried out by (Lu et al 2005) suitable snubber circuits must therefore be adopted, which affect power density and converter reliability. The zero-voltage transition approach, as well as the active-clamp snubber approach, leads to zero-voltage switching of the transistors and zero-current switching of the diodes (Citko and Jalbrzykowski 2008, Yao et al 2004, Johan Park et al 2012). These approaches have been successful in substantially improving the efficiencies of transformer-isolated converters. Wu et al (2008) deal with the analysis and derivations for a ZVS converter based on a new active clamp ZVS cell. When the FB converter transits from zero state to active state, the clamping diode conducts and its initial current equals to the peak resonant current due to the resonance of the resonant inductor and the parasitic capacitor of the output filter rectifier diode. The increase in output filter inductor current leads to decaying in clamping diode current. The output filter inductor is always designed to be large. Since the rise rate of its current is very small, the conduction time of the clamping diode will be longer. Therefore the conduction loss will be more in clamping diodes, resonant inductor, and leading switches.

In order to achieve full ZVS operation with unlimited load and wide input voltage range a large inductance is provided in series with the primary winding of the transformer. This increase in inductance causes an increased loss of duty cycle on the secondary side and voltage ringing across secondary side output rectifiers. Citko and Jalbrzykowski(2009) have described bidirectional DC to DC converter which employs the two bridge configuration resonant converters on both sides of the isolating transformer. The system has good dynamic properties and high efficiency because the converter transistors are switched in ZVS conditions.. Lin and

Tseng (2007) have described the parallel-connected asymmetrical soft-switching converter. A number of power converters connected in parallel, share the load current so that each converter operates with a load which is a fraction of its full load. The converter is able to maintain a high efficiency at light loads.

Wang (2008) has presented a novel ZCS-PWM fly back converter with a simple ZCSPWM Commutation cell. A LC resonant tank circuit is utilized for shaping the device's current wave form. Zero current condition is created by allowing the device to switch under favourable conditions. These circuits are hybrid converters between PWM converters and resonant converters. Zhang et al (2006) have presented a novel zero-current transition full bridge DC-DC converter and C tank circuit is always present near the power switch. It is used to shape the current and voltage waveforms of the power switch and also to store and transfer energy from input to output similar to the conventional resonant converters. However due to capacitor turn on, the zero current transition has the problem of high switching loss. Song and Huang (2005) have presented a novel zero-voltage and zero-current switching full-bridge PWM converter. ZVS and ZCS techniques are applied to PWM converters to improve efficiency and overcome the reverse recovery problem. However, the main switches are suffering from additional current stress and the auxiliary switch voltage stress is high.

This paper presents an improved efficiency phase shift softswitching pulse modulated full-bridge DC- DC converter with a high frequency transformer stage and front-end boost converter cascade stage, which includes soft-switching full bridge diode rectifier operating on the basis of the resonant operating principle and inherent nature of the secondary-side LC series resonant circuit. This new DC-DC power converter suitable for solar converter can achieve not only soft-switching transition based on ZVS in the primary-side, but also ZVS and ZCS commutation for the full-bridge diode rectifier in secondary-side. The operating principle of this DC- DC converter in a periodic steady-state is described by using switching mode equivalent circuits and simulation analysis, along with its inherent remarkable features as compared with conventional ones. The simulated operating voltage and current waveforms are comparatively illustrated in experimental ones. The actual efficiency vs. output power characteristics and power loss analysis are demonstrated from an experimental point of view. The practical effectiveness of the proposed converter are confirmed and verified by

setup implementation and simulation analysis.

III. NEW SOFT SWITCHING DC-DC CONVERTER

The proposed converter topology is shown in Fig. 2. To the energy flow from the low to the high voltage side, the boost converter (L) is controlled and the high side converter (H) is not controlled but operates as a rectifier. To the energy flow into the opposite side the buck converter (H) is controlled and the low side converter (L) operates as a rectifier. The main problem of this solution is the use of the same resonant circuit elements for the both directions of the energy flow. As the authors' theoretical investigation shows, such a situation is impossible and an additional capacitor must be used when the system operates in the buck mode. This capacitor C is joined by the additional switch shown in Fig. 2(a),2(b).

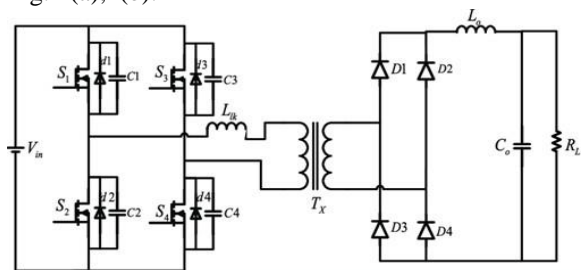

Fig.2(a). Full Bridge Phase Shifted Converter

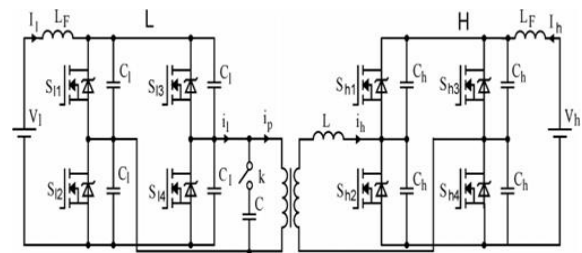

Fig.2(b). Proposed bidirectional DC-DC converter topology

Figure 2 illustrates the relevant voltage and current operating waveforms during a complete switching period for the gate driving pulse sequences. The switching operating modes of the soft-switching full- bridge DC-DC converter with a high frequency transformer are divided into 6 operations modes from mode 1 to mode 7 in accordance with operational timing points from t_0 to t_7 . As can be seen in Fig. 3, the operation principle is described with the equivalent circuits corresponding to each operating mode.

A. OPERATING PRINCIPLES

The first half cycle modes of operation are explained by

4 circuit modes of operation. The second half cycle the event repeats in the same manner as that of first cycle.

Mode 0

In this mode, the switches T1 and T2 are on and power is transferred from input to output. The mode is shown in fig 3(a).

Mode 1

In mode 1, the switch T1 is turned off and the primary current flows through C1 and C4. The primary current charges C1 to VDC and discharges C4 to zero. The energy required to charge and discharge is provided from the energy stored in the leakage inductor Llk.

Mode 2

In mode 2, the capacitor C4 is discharged to zero and the freewheeling diode DR4 of switch T4 is forward biased and starts conducting. Beyond this, the switch T4 can be turned on with zero voltage across it and zero voltage switching turn on can be obtained. This is shown in fig 3(c).

Mode 3

In this mode, switch T2 is turned off and the primary current flows through the capacitors C2 and C3. This current charges C2 and discharge C3. The capacitor charges to VDC and the capacitor C3 discharges to zero. This is shown in fig 3(d). The energy required to charge and discharge the capacitors are provided by not only the leakage inductance of the transformer but also the energy stored in the output inductor.

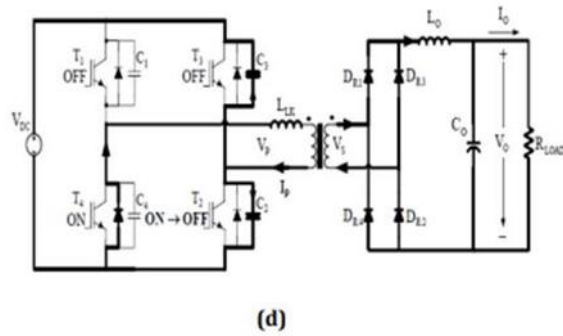
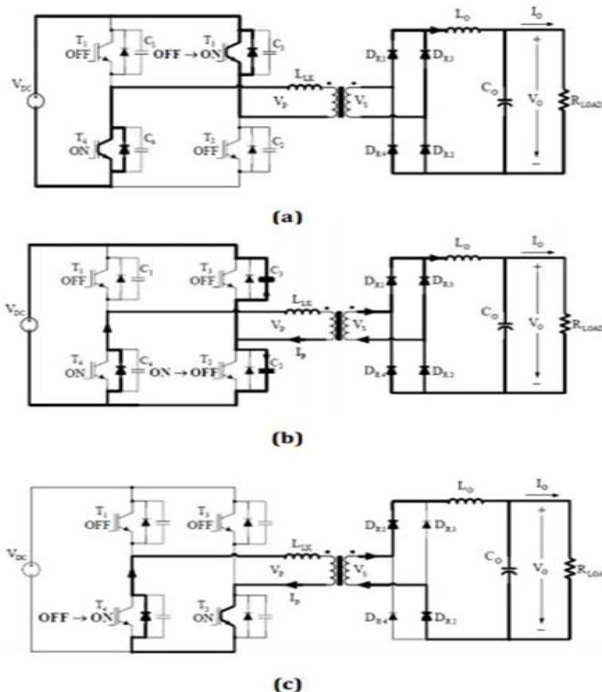

Mode 4:

Start : MT2, MT4 and MT5 are under the conducting mode At t0: MT2 is switched off while MT4 & MT5 remain turned on C1, C2 and LK are formed as a resonant circuit The inductance current i_L is decreasing from the largest negative value C2 starts discharging until completely discharged .

Mode 5:

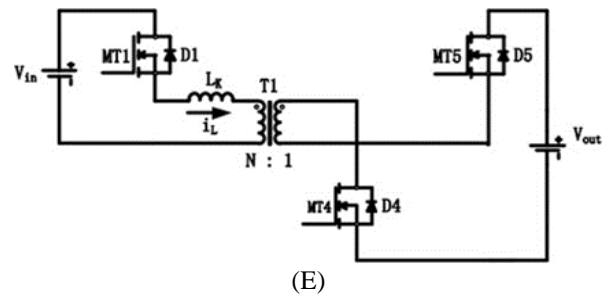

Fig -3: Modes of operation

After t1: MT1 is turned on under the ZVS condition. At t2: the inductance current i_L is decreased to zero. The expression of the i_L can be derived in the following step:

Mode 6:

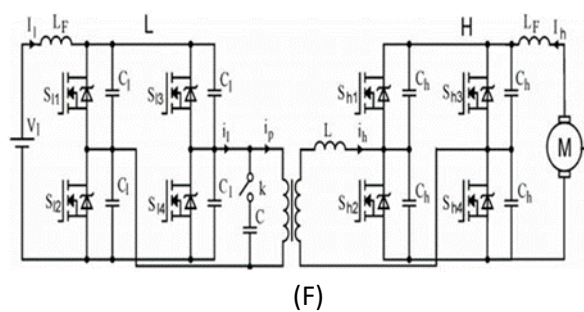

Fig. 4. Experimental circuit of the bidirectional DC- DC converter test

After t2: MT4 will be turned off and MT3 will be turned on under ZCS condition The secondary side is shorted. The input voltage is directly applied on the inductance LK Leads the current of i_L increases linearly and it equals:

Mode 7:

After t_3 : the MT5 turns off [$t_3 - t_4$] is the time of dead band: avoids the MT5 & MT6 turning on simultaneously The C5, C6 and Lk form the resonant circuit until the C5 reaches the output voltage The voltage of C5 is given by:

$$i_L(t) = i_L(t_2) + \frac{[V_{in} * (t - t_2)]}{L_k}$$

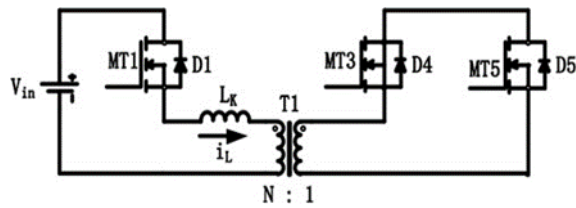

$$u_{c5} = \sqrt{N^2 V_{in}^2 + [i_L(t_3)/N]^2 * Z_2^2 * \sin[\omega_{r2}(t - t_3) - \theta]} + N * V_{in}$$

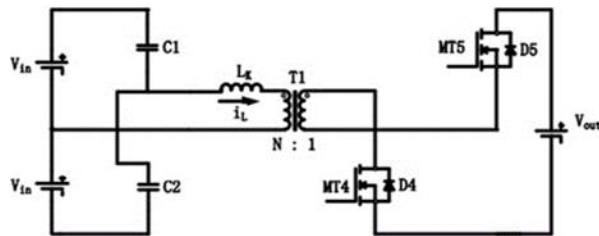
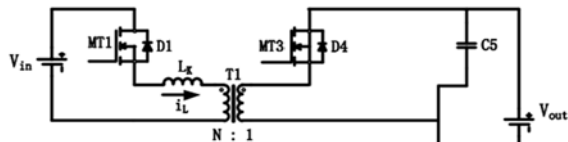

$$i_L(t) = i_L(t_1) + \frac{1}{L_k} * V * dt \quad \rightarrow \quad i_L(t) = i_L(t_1) + \frac{[V_{in}(1 + d) * (t - t_1)]}{L_k}$$

IV. EXPERIMENTAL RESULTS

The proposed bidirectional DC-DC converter prototype was built and tested in experimental circuit shown in Fig. 4. The accumulator $V_1 = 12\text{ V}$ was used as low voltage sources (storage element). As the high voltage $V_h = 12\text{ V}$ source was used DC motor coupled.

The phase shifted full bridge dc-dc converter is simulated using MATLAB Simulink software with parameters as follows: Input voltage $V_s = 400\text{ V}$ Output voltage $V_o = 12\text{ V}$ Switching frequency $F_s = 100\text{ kHz}$ The proposed converter was simulated using the parameters to verify the operating principle, advantages and performance efficiency of the converter. The conventional full bridge dc-dc converter is compared with the phase shifted full bridge dc-dc converter and the advantage ie, the zero voltage switching was obtained. From the comparison between the two converters, it was

found that the phase shifted full bridge dc-dc converter has reduced switching and conduction losses and higher efficiency as compared to the full bridge dc-dc converter. The simulation model and the results are shown below.

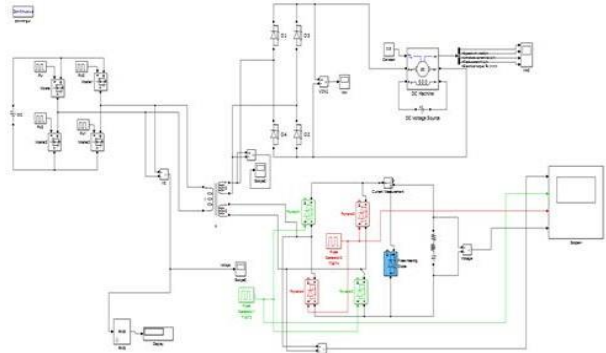

Fig -5: SIMULINK Model of phase shifted full bridge dc-dc converter

WAVEFORMS

The figures 5, 6, 7 shows the key waveforms of phase shifted full bridge dc-dc converter. The primary and secondary voltages with the input voltage of 400V and output voltage of 12V are as shown in figure 5. The output voltage waveforms are shown in figure 6 and figure 7 shows the zero voltage turn on of the switch.

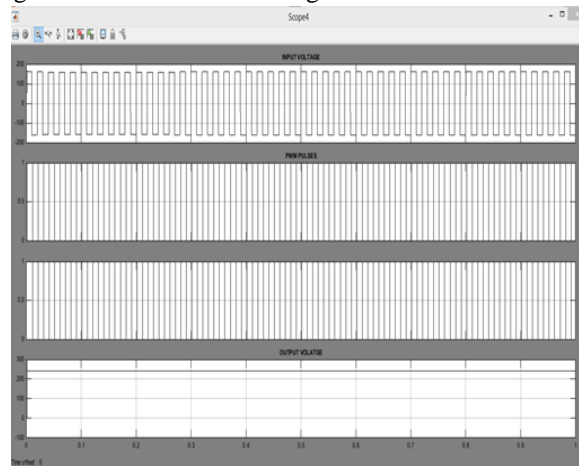

Fig -6: Output voltage

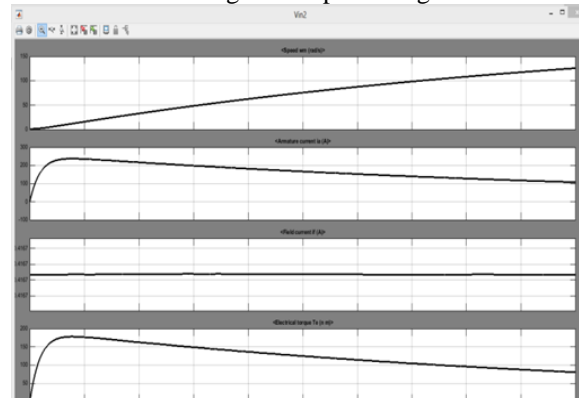

Fig -7: DC Machine Performance

V. CONCLUSION

This paper has presented the phase shifted full bridge dc-dc converter which can solve the problems of full bridge dc-dc converter such as high switching losses, conduction losses, high EMI and lower efficiency. The theoretical analysis of the phase shifted full bridge dc-dc converter is presented to show the advantage of phase shifted full bridge dc-dc converter over traditional full bridge dc-dc converter. The experimental results are shown in the figures above which clearly show the advantages of the proposed converter and zero voltage switching is obtained which improves the efficiency of the converter. The phase shifted full bridge converter is used in medium to high voltage applications such as power supplies, battery chargers, renewable systems etc.

REFERENCE

- [1] C.T.Manikandan, Performance Analysis of Solar Based High Stepup DC-DC Converters with Various Filters, 2018 IEEE International Conference on Computational Intelligence and Computing Research (ICCIC), 13 to 15 Dec 2018
- [2] R.Dharmaprakash and Joseph Henry, "Investigation of Three Level Diode Clamped Inverter Switching Tables without Using Medium Vectors for Direct Torque Control of Induction Motor", Middle-East Journal of Scientific Research Vol. 23, 89-96, 2015, DOI: 10.5829/idosi.mejsr.2015.23.ssps.23
- [3] R.Dharmaprakash and Joseph Henry, "Investigation of Three Level Diode Clamped Inverter Switching Tables without Using Medium Vectors for Direct Torque Control of Induction Motor", International Journal of Applied Engineering Research, Vol. 10, No.17, 2015, pp 12836-12842.
- [4] Deepa S., Samuel rajesh babu., Ranjani (2014) "A Robust Statcom Controller Using Particle Swarm Optimization", IJE TRANSACTIONS B: Applications. Vol. 27, No. 5 pp.731-738.
- [5] Mr.V.Sudharsan, "Hardware efficient realization of an autonomous robot with UART based control for navigating static and dynamic obstacles", International Journal of Mechanical and Production Engineering Research and Development , Vol. 9, no. 3, pp. 837-845 & 2018
- [6] M. Padmarasan, R. Samuel Rajesh Babu, "MSRF Control Based Interline Dynamic Voltage Restoration in Distribution Line", International Journal of Recent Technology and Engineering, Volume-8 Issue-5, pp.1-5
- [7] Lavanya Dhanesh and Dr.P.Murugesan, "Analysing the WCET by implementing Cyclic Priority Pre-Emptive Task Scheduling algorithm" in the International Journal named "Far East Journal Of Mathematical Sciences" ISSN 0972-0871 Volume 97, Number 6, 2015 pp.667-688
- [8] M.A. SalaiKumutha, M. Vasugi and R.Dharmaprakash, "Voltage Ripple Reduction of Buck Converter using Sliding Mode Control Technique", Middle-East Journal of Scientific Research Vol. 23, 83-88, 2015, DOI: 10.5829/idosi.mejsr.2015.23.ssps.23
- [9] Deepa S. Rajapandian.S., (2010), "Implementation of DVR for voltage sag mitigation", International journal of Engineering science and technology, Vol.2 No.10, pp.5825- 5830
- [10] G. N. B. Yadav and N. Lakshminarasamma, "A new active soft switching circuit for full bridge converters," in Proc. IEEE Int. Conf. Power Electron, Drives Energy Syst., Dec.2012.
- [11] Dunisha S. Wijeratne and Gerry Moschopoulos, "A ZVS-PWM Full-Bridge Converter with Reduced Conduction Losses", IEEE Trans. Power Electron. vol. 29, no. 7, July 2014.
- [12] Hyun-Lark Do, "A Soft-Switching DC/DC Converter with High Voltage Gain", IEEE Transactions on power electronics, Vol. 25, no. 5, May 2010.