

Electric Vehicle from Two-Wheeled Ic Engine Vehicle Remodel.

Shrikrishna P. Giripunje¹, Shiwani Rasekar², Vishal Pimpalkar³

¹Lecturer, Electrical Engineering Department, Ballarpur Institute of Technology, Ballarpur 442701

²HOD (Polytechnic), Electrical Engineering Department, Ballarpur Institute of Technology, Ballarpur 442701

³Assistant Professor, Electrical Engineering Department, Ballarpur Institute of Technology, Ballarpur 442701

Abstract—The reason for this article is to examine the feasibility of changing over traditional bikes with internal combustion engine to electric drivetrains. Introduce an electric engine, battery pack, engine regulator, and other electrical frameworks, ICE parts should be taken out. As per fundamental testing, bikes that have been retrofitted can arrive at execution boundaries that are comparable to electric variants that are made in manufacturing plants, with eminent expansions in energy productivity and lower working expenses. Cost and natural reserve funds are the fundamental drivers of client adequacy, which is by and large positive. The review shows how retrofitting can be a reasonable and harmless to the ecosystem answer for charge current bike armadas, opening the entryway for more extensive reception and other innovative turns of events.

I. INTRODUCTION

The quantity of engine vehicles has duplicated, with floods addressing only one of these gases, carbon dioxide and nitrogen oxides, which contribute the most to an Earth-wide temperature boost. In a bid to bring down outflows from fuel vehicles, a reasonable and manageable arrangement has been created: changing over existing petroleum vehicles into electric ones. An undertaking pointed toward changing existing petroleum vehicles to electric ones depends on the first suspension and incorporates a commitment from the Brushless DC engine (BLDC), which drives against superior execution however perseveres for quite a while. This permits the fuse of cutting edge frameworks, for example, regenerative slowing down and energy the executives plots, that make the framework all the more harmless to the ecosystem as well as present day, despite the fact that

it was connected to engines initially designed 50 years prior. The undertaking is supposed to decrease fossil fuel byproducts and backing practical transportation by changing over ordinary petroleum vehicles into electric vehicles through the idea of retrofitting. The first frame was safeguarded for underlying scaffolding, and cost reserve funds through an exceptionally incorporated BLDC Center point engine, battery set, and regulator were created as the fundamental power hotspots for retrofitting. An electric vehicle might have an installed battery of capacity that drives an engine for development, and afterward controls the stream advancing power conveyance over different procedure on vehicles. The battery is charged utilizing the primary power and a fitting with the guide of a charging unit, which should be possible installed or at assigned evolving stations. The regulator deals with the power result to keep the electric engine running accurately and controls the driving pace in sending or opposite.

II. LITERATURE REVIEW

This review of the literature seeks to understand why electric two-wheelers are becoming highly favoured and transitioning toward cleaner sources, as well as their technical applicability. The Output covers the introduction of electric vehicles, retrofitting of internal combustion engine vehicles, Technical Analysis in detail and performance analysis, and challenges with future work. The battery management system reviews The BMS is very much importance about the user acceptance, regulatory compliance and technical ability. This review also examines the environmental benefits of electric two-

wheelers over traditional vehicles, which are seen as having a positive impact if they take off on a large scale. It also helps with the need to develop uninterrupted EV infrastructure.

III. PROPOSE METHODOLOGY

Electric scooters are also convenient to use, because they make commuting easier for riders. Powered by an electric motor and gearbox system, a lithium-ion battery is used to power the carryover operation. The throttle, which is rotated or pressed up and down to regulate the flow of power from the battery to the motor, determines how fast it goes. The quality of the motor also influences speed, torque, and climbing ability. Brushless motors are more efficient than brushed motors. The concept behind regenerative brakes is simple: during braking, all or part of the kinetic energy that is normally wasted as heat inside the disc or drum brake assemblies is converted into electrical energy. This energy is then returned to the battery; thus, the overall efficiency increases, and it will reach an extended range. The electric motor moves any propels of the scooter instead of using a conventional internal combustion engine to produce torque that drives the wheels. The battery pack is essentially a store of electrical energy, providing power to the motor when required, with the controller controlling and regulating the electricity flow from the source (battery) to provide precise control over speed and torque. When attached to a power source, the charger refills some of the stored battery capacity, so my (light) does not roll around the powerless whenever I want it. The electric motor replaces the original engine attached to the rigged frame of the scooter, and battery packs are generally distributed where there is space available (preferably under the seat). The controller is mounted on the two-wheeler and sits between the battery pack and the motor receiving user input from the throttle, as well as other controls. Some of the retrofitted EV scooters may have features such as a regenerative braking system; hence, reversed operation is also possible using the motor as an electrical generator that converts kinetic energy into electrical energy. These monitoring features can be in the form of battery charge indicators, overcharging safety mechanisms, and overheating/overcurrent protection. Electric scooters are simple and easy to use; therefore, they are

popular among customers. Powered by a battery and an electric motor through the gear mechanism, they convert electrical energy into mechanical energy for use in the driving wheels. This is one of the main things that connects you, as a rider, to this bike: throttle control, which determines how much or little your scooter is. The scooter parts are connected and managed via a controller, which can be a lithium-ion rechargeable battery pack. A scooter with a poor-quality motor will not hit similar top speeds, the same level of acceleration, and hill climbing ability as one with this stronger type. Brushless motors are more efficient – typically 85-90% compared to ~75%-80% for brushed equivalents. This is because electric scooters come with regenerative brakes where they charge the battery owing to the conversion of kinetic energy into power by providing a bit force oathbreach. The electric motor takes the place of the gasoline engine and acts accordingly to propel this scooter down the road. The battery pack holds electrical energy and provides power to the motor, while the controller directs electricity from the battery into the motor (thus controlling speed and torque). Once plugged into a power source, the battery pack charges using the charger it is plugged into the power source. The electric motor is positioned where the old engine used to be, and occasionally in or below a bicycle or trailer. The controller is mounted on the scooter and connected by a wire between the battery pack and motor, and it receives signals from throttle activation or other controls.

IV. COMPONENT DESCRIPTION



1. BLDC MOTOR

Combined with the mechanical transmission system, we must mention rapid acceleration, which is enabled by a 48V BLDC hub motor located in the rear wheel and provides seamless acceleration, probably requiring a perfect interface to obtain the maximum output even at temperatures from -20°C to enable

safe driving even when driving days for up. The motor is tough for rugged and efficient use on e-bikes and motorcycles that can withstand precipitation in rainy or humid conditions.

2. BLDC CONTROLLER



The vehicle's controller regulates the transmission of battery power and movement to the motor in such a way as to allow reversed motion. The speed and acceleration can be adjusted using pulse-width modulation. The BLDC controllers for 1000 W BLDC motors use brushless DC technology to generate power. A BLDC controller manages the overcurrent and temperature settings to maintain stability, and the firm actions of these two controllers protect motors from any type of damage. It can also be tuned further to deliver the specific torque and speed requirements of a given vehicle.

3. LITHIUM-ION BATTERY



Lithium-ion batteries are transparent, light, and rechargeable eco-friendly batteries used in modern electronics. Not only do they have a high energy density, but they also charge quickly and rarely require maintenance. Integrated into the systems of an electric vehicle, they offer a range of 30-40 km and a speed level of up to 25 km/h. Lithium-ion batteries are also relatively long-lived options, making them particularly cost-effective for a variety of applications. Similarly, technology is being advanced, and consequently, its functionality remains in the updating phase.

4. LITHIUM-ION BATTERY CHARGER



Lithium-ion battery chargers for smartphones, laptops, cameras, and electric vehicles will then divert the correct voltage and current levels at a chosen rate to do so effectively and safely. These chargers are packed with a slew of features, such as voltage regulation, current observation, and safety guards for no overcharging, overheating, and small-higher circuits (connectors on these cubic zirconia stone brick breaks). These chargers can be of various sizes and portability: some may either fit in a small pocket while others are integrated inside electronic devices themselves. The reason these are popular is that lithium-ion battery chargers can impact the life of the batteries, and the time after period guarantees that they have a hale protector against power issues. A smaller charger, this unit is rated for electric vehicles up to 48 V, with a maximum charging voltage of 54.6 volts. A self-contained circulation cooling system was used to prevent overheating during the charging process. In addition, it comes with an LED indicator that makes tracking the charge level of this battery easier for the users.

5. DC-DC CONVERTER

An important part of electric cars is the DC-DC converter, which makes it possible to electronically work with varying voltage levels during the conversion of electricity applications, including everything from fine-tuning the voltage to meet the specific needs of various electronic components in a car. It converts high-voltage DC power from the main two-wheeler EV battery pack to low-voltage DC power that is appropriate for use by accessories and other vehicle systems. The converter is available in three different input/output configurations that include 48, 60, or at what the manufacturer rates as a continuous output of up to one channel and up to watts. This results in better power utilization and dissemination throughout the vehicle, thereby improving performance. In addition, DC-DC converters offer an efficiency boost to allow electric vehicles to travel longer distances.

6. SWING ARM



What is a Swingarm on Motorcycles & ATVs? It takes the shock and waits for the suspension caused by movement, acceleration, or braking by the rider. The swingarm is made up of materials ranging from aluminium and steel to carbon Fiber and joins the motorcycle's frame using a pivot bolt. In the case of a twin or even mono-rear suspension, this system is anchored to the frame of the motorcycle and allows for up-down movement around the rear wheel. Swing arms can come in one of two configurations: single-sided and double-sided. The extended double-sided swing arms beside the wheel were stronger and more stable. On the other hand, single-sided swing arms are better when it comes to relieving the wheel, but they do have a unique look. It greatly influences the way a motorcycle handles and performs, as it determines the stability of our rear wheel control. Moreover, compared to modern swingarms, features such as the ability of different pivot points (or linkage systems) help a bike handle better.

7. CHARGING CONNECTORS



Two-wheeler electric vehicle chargers are unique interferences developed for charging connectors intended by various manufacturers to plug into Motorcycles, Scooters, or other similar vehicles. Consequently, they are tailored to the power requirements and battery configurations instead of offering a universal connector. Custom designed for each vehicle model, these connectors are essential for efficient and safe charging of EVs. If customers want to enjoy a smooth charging experience, manufacturers should focus on assessing the compatibility of these chargers with potential connectors.



8. BATTERY LEVEL INDICATOR

A battery level indicator (BLI), or simply a battery gauge, is an important instrument in BEVs for

determining which portion of the entire charging capability remains on hand. For example, they can decide whether the current amount of charge will really take them to a desired destination; this helps in planning future recharge halts accordingly. This helps to avoid sudden, unprepared stops on the road because of battery discharge.



9. SHOCK ABSORBER

In a bike suspension system, shock absorbers play a critical role in improving the stability of the bike on the road, steering accuracy, and braking responsiveness, all of which help keep the tires in contact with the pavement. The comfort of the car is significantly reduced without shock absorbers, resulting in an uncomfortable and bumpy ride. They also contribute to extending the life of the suspension system by reducing the damage to other suspension system parts.

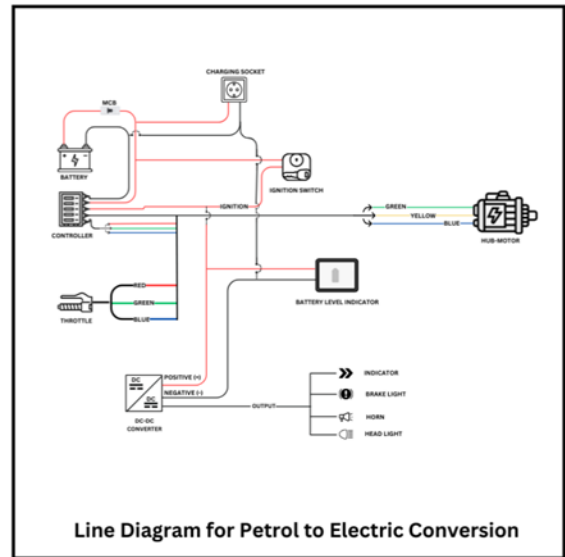

10. CONNECTION DIAGRAM

V. ADVANTAGES

- Electric vehicles (EVs) are more environmentally friendly alternatives to traditional vehicles that emit

zero tailpipe emissions and reduce air pollution and greenhouse gas emissions.

- Electric vehicles (EVs) produce zero tailpipe emissions and reduce air pollution and greenhouse gas emissions.
- EVs typically have lower operating costs than traditional vehicles because of their lower fuel and maintenance costs.
- Electric motors in EVs are more efficient, leading to lower energy consumption and longer range per charge.
- EVs are quieter and contribute to reduced noise pollution in urban areas, which is beneficial for the environment. They provide instant torque, resulting in rapid acceleration and responsive performance.
- EVs reduce dependence on fossil fuels, promoting energy independence and resilience.
- Customization and personalization of the vehicle according to the owner's preferences is possible, allowing for individualized modifications.

VI. DISADVANTAGES

- Retrofitting electric vehicles (EVs) can be costly, particularly if high-quality components are required.
- However, upfront costs may be offset by savings in fuel and maintenance.
- Retrofitted EVs may have a shorter range than purpose-built vehicles, and their battery capacity and efficiency may not be designed for the maximum range.
- Retrofitting may cancel the original vehicle's warranty, making the owner liable for repair and maintenance problems.
- Additionally, retrofit kits may not have comprehensive support networks compared with established manufacturers, and finding qualified technicians or spare parts can be challenging. Limited charging infrastructure for EVs, such as insufficient two-wheeler charging stations, may present significant obstacles.

VII. CONCLUSION

E-scooters are becoming popular alternatives to gas cars because of their eco-friendly nature and ability to travel in remote areas. Given increasing fuel costs, the EV outlook for electric vehicles appears bright.

The e-scooter comes with a 48V, 50Ah lithium-ion battery that can reach speeds of 60 mph and charge up to 2200 Wh in 5 hours. Advancements in technology and government support for eco-friendly transportation could boost the adoption of e-scooters.

VIII. ACKNOWLEDGMENT

I am glad to share the paper "Remodel an Electric Vehicle from Two-Wheeled IC Engine Vehicle." I would like to express my gratitude to Prof. Vishal M. Pimpalkar, Head of the Electrical Engineering Department at the Ballarpur Institute of Technology, Chandrapur. I appreciate the support and direction he has provided for my project. Prof. Vishal M. Pimpalkar is grateful for his kind assistance. Their insightful recommendations are beneficial. I am thankful for the guidance and ability of my project advisor, Mr. Rajesh K. Deshmukh, who helped me navigate the challenges of this project. His mentorship was invaluable for ensuring the success of my research and development efforts.

REFERENCES

- [1] Electric Vehicle Outlook (EVO) (2023). Global electric vehicle market trends toward EVO.
- [2] Salvatore, M., et al. (2020). Retrofitting ICE vehicles to electric: Technical and economic considerations. *Journal of Cleaner Production*, 242,118408.
- [3] Kumar, R., & Srinivasan, V. (2021). Components and challenges in retrofitting Two-wheeler to electric. *International Journal of Electric and Hybrid Vehicles*, 13(3), 255-269.
- [4] Zhang, Y., et al. (2019). Performance analysis of Retrofitted electric scooters. *Energy Reports*, 5, 701 710.
- [5] Singh, A., & Kumar, S. (2022). User Acceptance of retrofitted electric two-wheelers in urban India. *Journal of Sustainable Transportation*, 10(2), 148 161.
- [6] Silva, C. et al. (2020). Challenges and prospects for vehicle retrofitting. *Renewable and Sustainable Energy Reviews*, 130, 109964.