

Real Time Monitoring Sign Language Translation Glove

Gourish Kattimani¹, Roselin M², Ranjita K.D³, Ranjana M⁴, Sharanu K⁵, Akash B⁶

^{1,2}Asst. Prof Dept of ECE, Rural Engineering College, Hulkoti, Karnataka

^{3,4,5,6} Dept of ECE, Rural Engineering College, Hulkoti, Karnataka

Abstract—Communication is an issue that still persists as one of the major problems for millions of people across the globe suffering from speech and hearing disability, resulting in their isolation and dependence on human interpreters. Although there exist many sign language recognition systems that typically involve the use of cameras and complex image processing, and which is often dependent on lighting conditions and costs involved along with privacy concerns as well, this paper proposes an alternative that is portable and wearable.

The proposed system has a smart glove on which five flex sensors are mounted on the fingers, which identify the specific degree of bending for different sign gestures. The flex sensors function as resistive devices, and the variation in their resistance is measured as an analog signal to be further processed with an Arduino Nano microcontroller (ATmega328P). The microcontroller includes predefined calibration ranges and threshold algorithms to recognize hand gestures in real time. After recognition, the system gives dual-mode output: text translation visually displayed on 16x2 I2C LCD and speech audibly produced through the DF Mini Sound Module and a 0.5W speaker.

The prototype is fueled by a rechargeable lithium-ion battery and is completely able to make a smooth shift from imperceptible physical movements to intelligible communication within a fraction of a second. The assistive technology provides a powerful and easy system for deaf-mutes to convey their needs on their own.

I. INTRODUCTION

Millions of people worldwide face speech and hearing disabilities. They use a combination of signs, known as sign language, to communicate with others. They make use of finger, hand, and arm movements to speak. However, since others do not comprehend this form of communication, it is difficult for them to have convenient social gatherings, communication, and dependence on others. They have to face social isolation, communication delays, and dependence on

others due to others' inability to comprehend the interaction.

Sign language recognition systems belong to a significant class of research in human-computer interactions as well as assistive technology. In conventional sign language systems, cameras are used along with image processing techniques, but such systems also have various disadvantages, such as costs, inflexibility, dependence on lighting conditions, as well as privacy-related problems. Thus, as is evident, wearable-based systems are put forward as alternatives. This project proposes a glove-based sign language translation system via flex sensors, which can identify the extent of bending of fingers based on sign language, processed via Arduino Nano, and appropriate pre-recorded voice messages are played via DF Sound Module along with speaker and text displayed on I2C LCD.

This low-cost and straightforward system can be implemented at all the public places like hospitals, schools, offices, railway stations, airports, etc., for deaf-mute persons to reduce their communication gap and increase social independence.

II. LITERATURE SURVEY

A wide literature survey is carried out, which helps in exploring the existing research and scholarly articles pertaining to the specific research topic. It is aimed at understanding important themes, theories, and research articles that have contributed largely in defining the present-day understanding of the subject, and how the literature can be extended by addressing the gaps and contradictions. This helps in laying a good platform for the research by establishing its significance in the overall academic sphere.

2.1 The research on sign language gloves can be traced back to studies on early sign language glove

developments, such as the CyberGlove, employing costly motion capture technology for sign language recognition. Similarly, other pioneering glove developments employed expensive motion capture technology for sign language recognition. Infact, though the glove development was pioneering, it was bulky for day-to-day usage. Presently, research has clearly spurred towards low-cost flex sensors for detecting finger movement, addressing the ability to identify static signs. There has been substantial emphasis on various research papers on the integration of accelerometer and gyroscope technology for sign language recognition, considerably enhancing recognition accuracy. Similarly, the latest research trends on sign language gloves imply the use of Arduino, ESP32, and other microcontrollers. Furthermore, various other research papers have concentrated on reducing glove weight to improve usability. Even though the sign language glove has improved over the years, the challenges of sensor drift, sensor calibration, and sign language differences from one user to another make matters difficult. Throughout the development of the sign language glove, various improvements aim to improve sign language recognition accuracy, cost, and usability[1].

2.2 Much current research in the area of sign language gloves is directed towards the investigation of a variety of sensor technologies for the detection of gestures. Although flex sensors remain the most widely used due to their capability of detecting finger curvature, studies have indicated that they are prone to wear and have limited lifetimes. To that effect, more recent studies introduce fabric-based strain sensors, capacitive sensors, and optical fiber sensors implemented in glove material. IMUs, which comprise both accelerometers and gyroscopes, are also commonly used to detect hand motion, orientation, and acceleration, enhancing the recognition of dynamic gestures. A number of studies emphasize the advantages of combining multiple sensor types to achieve more reliable classification. However, the literature does point to various challenges concerning the increased complexity, higher power consumption, and the requirement for advanced methods of signal processing. Generally, the research concerning sensor technology significantly enhances the performance of sign language gloves by making them more accurate

and user-friendly and stimulates innovation towards flexible, durable, and low-cost sensing materials.

2.3 Machine learning is seen as one of the significant features of the current technology in sign language gloves. Several research articles are focused on the evaluation of various machine learning algorithms for the classification of gestures and translation. With the shortfalls of the traditional implementation of rule-based systems in the earlier works for the interpretation of gestures, the use of various machine learning techniques such as kNN, SVM, Decision Trees, Random Forests, and the recent implementation of deep learning mechanisms such as CNNs, RNNs, and LSTM for the recognition of dynamic gestures seems dominant. In one of the works, accuracy levels of up to 95% were achieved. However, it can be observed that several researchers are of the view that the implementation of machine learning mechanisms required the use of sufficient data for training the models, as the accuracy levels were shown to improve with the increased use of computing systems. Machine learning technology appears to be the dominant trend in the improvement of the accuracy of translation with the use of sign language gloves[3].

2.4 There is detailed research comparing glove-based gesture recognition systems and camera-based systems, indicating the advantages and limitations of both systems. In camera-based systems, cameras and computer vision techniques are used to understand gestures by viewing the shape of the hands without touching or making contact with the hands themselves. There is freedom of movement with camera-based systems. According to literature reviewed, some limitations associated with camera-based systems are sensitivity to light conditions, background complexity, and limitations of dealing with overlapped gestures. In glove-based systems, sensors detect signals directly from the gloved hands and can operate effectively under complex light conditions or when dealing with overlapped gestures. Research has concluded that glove-based systems perform better than camera-based systems under mobile conditions, outdoors, and under poorly equipped conditions. There is also literature that

suggests integrating both systems, using sensors and visual detection of gestures to increase accuracy;

however, this would require developing cost-consuming systems.[4]

III. BLOCK DIAGRAM AND WORKING PRINCIPLE

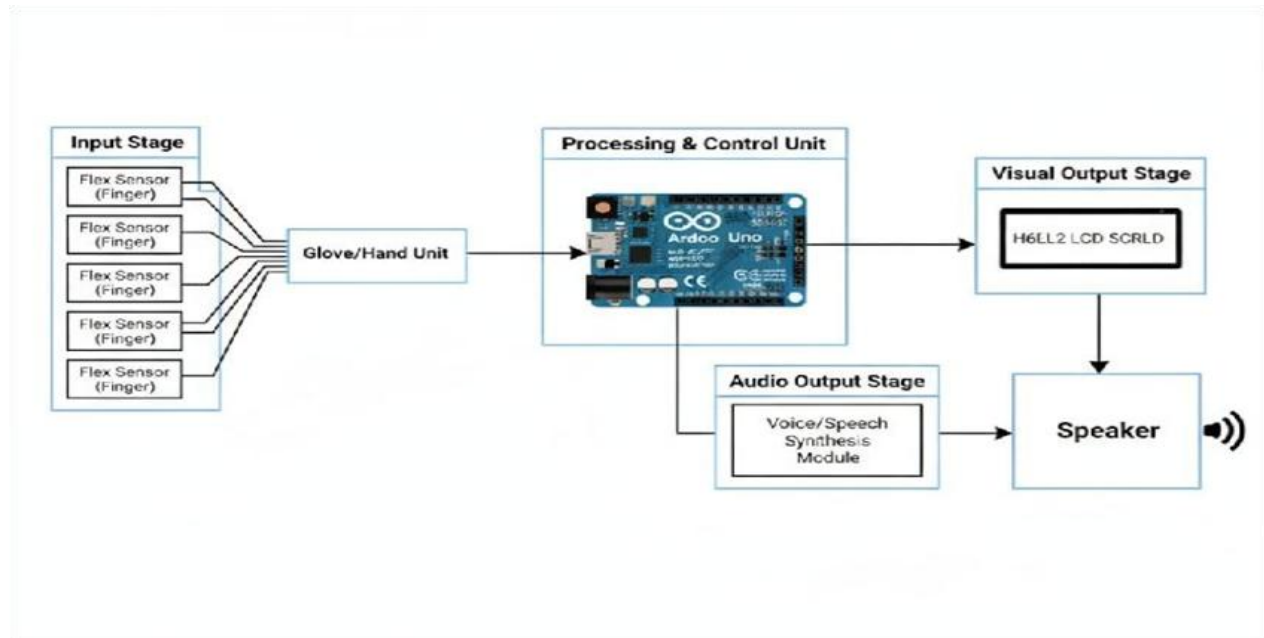

Fig 3.1 Block Diagram of real time monitoring sign language translation glove

3.1 Input stage

For instance, The Input Stage mainly comprises numerous flex sensors that are placed on each finger of a glove or hand unit. This type of sensor is resistive in nature, meaning that its resistive value will increase when it is flexed or bent. Therefore, when an individual makes a hand gesture that corresponds to and is characteristic of a given sign language symbol, each of the fingers of the glove unit will sweep or bend to varying degrees. This means that varying levels of resistance will be produced by these sensors, which is characteristic of each gesture made by the user. These varying analogue voltage values are obtained from the sensors through a voltage

3.2 Processing and Control Unit

However, the core of the whole system is the Arduino Nano (ATmega328P), which performs the duty of the Processing and Control Unit. It takes the analog signals from the flex sensors and converts all of this into digital using its 10-bit ADC (Analog to Digital Converter). The Arduino continuously checks the varying voltage levels of all the sensors of the fingers

and compares these with the predetermined levels stored in its memory, which correspond to specific sign language gestures programmed during training.

3.3 Visual Output Stage

The decoded sign language gesture is relayed to the 16x2 LCD Display, serving as the Visual Output Stage. The LCD immediately shows feedback to the user and the surrounding audience by indicating the text corresponding to the sign just executed by the user. Displaying the text of the recognized gesture assists in verification and is a confidence booster for the user. If, for instance, the user signs "HELLO," the LCD displays "HELLO" in real time. In noisy environments or places where audible output might not reach distinctly, this stage is very useful. The LCD has been interfaced to Arduino through digital pins or I²C communication, and the microcontroller sends character data along with appropriate control commands for updating the display. This makes the system more user-friendly and allows observers to easily understand the message being communicated.

3.4 Audio output stage

The Audio Output Stage comprises a voice/speech synthesis module, which is connected to a speaker. Once the Arduino has identified the gesture, it sends a command or a corresponding text string to the voice module. Here, the module, which may be pre-loaded with audio clips or may use a speech synthesis facility, produces audio output corresponding to the identified sign language gesture. A speaker then plays loud and clear speech, thus conveying the meaning of the sign language gesture made by a person. This Audio Output Stage is of immense use when we consider various real-time scenarios, as the LCD screen may not be accessible. Both voice and speech synthesis facilities in this module enable communication by playing an audio output, even if a person is unable to see the LCD screen.

IV. COMPONENTS

1. Flex sensors
2. Arduino Nano – ATmega328P
3. LCD Display 16×2
4. 8-ohm miniature speaker

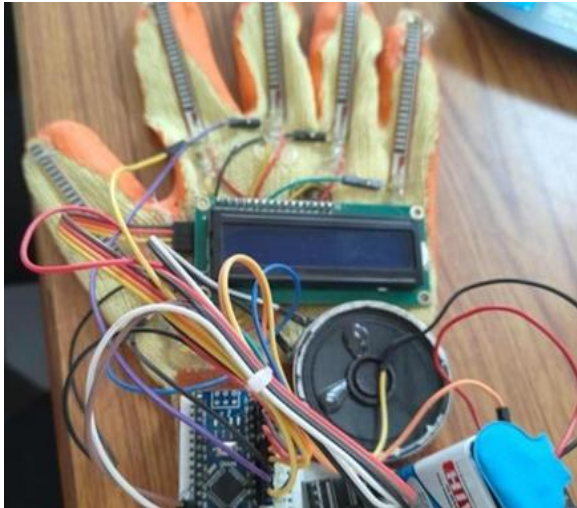

Figure 4.1: Hand Unit

The smart sign language glove is a wearable assistive device intended to overcome the communication barrier for the speech and hearing impaired by converting hand gestures to text and speech in real time. This device comprises a number of key components to ensure a smooth transformation from motion to sound.

V. APPLICATIONS

1. Assistive Communication for De

It converts hand gestures or sign language into spoken words, thereby helping users communicate with people who do not understand sign language.

2. Rehabilitation &

Flex sensors have the capability of tracking finger movement progress for patients who are recovering from strokes or hand injuries.

3. Human-Computer Interaction (HCI)

Can be used to control computers, robots, or smart devices using hand movements.

4. Virtual Reality (VR) & Gaming

Allows for natural hand-gesture control inside VR environments or gesture-based gaming.

VI. CONCLUSION

The wearable system effectively addresses the challenges encountered in health monitoring, environment adaptation, and communication in extreme environments. This is ensured through the incorporation of highly sensitive sensors, a Peltier module to facilitate temperature regulation, and a GSM modem to enhance communication. The incorporation of gas sensors and a "help me" button in the proposed design makes the wearable suitable for extreme environments. This ensures the tireless generation of vital information in case of emergencies. It is thus suitable for diversified environments.

applications, such as military, health, and industrial, in which users are subjected to extreme weather or dangerous conditions, thereby providing a comprehensive solution for improving safety and health.

REFERENCES

- [1] Das P, R Kanna, and A Bose." Hand Gesture Recognition for sign Language to Speech Conversion" Proceedings of the IEEE International Conference on Human- Machine Interaction 4, no. 3 (2022): 456 462.
- [2] Wilson, T., K Chen, and L. Park." Real -Time Sign Language to Speech Conversion Using Deep Learning." IEEE Transaction on Human-Machine Systems 52, no. 3 (2022): 789 798.

- [3] Sharma A., R. Patel, and V. Kumar “A Framework for Sign Language to Speech Conversion Using Gesture Recognition Method,” Proceedings of the IEEE International Conference on Smart Computing and Electronic Enterprise 1, no. 1 (2023): 102-108.
- [4] Uyyala P.” Sign Language Recognition Using Convolutional Neural Network.” Journal of Interdisciplinary Cycle Research 14 (2022): 1198-1207.
- [5] Mahesh, M., A. Jayaprakash, and M Geetha. “Sign Language Translator for Mobile Platforms.” In proceedings of the 2017 International Conference on Advances in Computing, Communications and Informatics (ICACCI), 1176-1181. Udupi, India: IEEE, 2017.
<https://doi.org/10.1109/ICACCI.2017.8126001>.
- [6] Truong V.N.T., C. Yang, and Q. Tran.” A Translator for American Sign Language to Text and speech.” In Proceedings of the 2016 IEEE 5th Global Conference on Consumer Electronics (GCCE), 1-2. Kyoto, Japan: IEEE, 2016.
<https://doi.org/10.1109/GCCE.2016.7800427>