

10 Km Communication System Without Using SIM/Internet/Wi-Fi

Rahul Laxman Mane¹, Onkar Dinesh Gaikwad², Suhas Somanath Bhosale³, Nagesh Ramchandra Adat⁴,
Aakash Dhanraj Girigosavi⁵, Laxmidas Sukhdev Khade⁶
^{1,2,3,4,5,6}*Karmayogi Institute of Technology (Polytechnic), Pandharpur, India*

Abstract—A communication system plays an important role in modern society, especially in the disaster-affected areas where the conventional network may not be available or may fail during disasters. This paper presents the design and implementation of a long-range communication system capable of achieving distance upto 10 kilometers without using the SIM cards, internet connectivity and Wi-Fi networks. The proposed system is based on the low-power long-range wireless communication technology which is known as LoRa(Long Range) technology. This system enables the text communication between the two devices over large distances(upto 10 kilometers) while consuming minimal power. The transmitter unit sends the message through LoRa Module, which is received by the corresponding receiver module and it is then displayed over display. The developed system can be useful in applications such as rural communication, disaster management, military operations and emergency communication where conventional network infrastructure fail or unavailable. The proposed model provides a cost-effective, portable, and energy-efficient solution for long-range communication.

I. INTRODUCTION

Reliable communication over long distances is an essential requirement in many real-world applications such as disaster management, rural connectivity, and emergency communications systems. Most existing communication technologies mainly depend on cellular networks, internet connectivity, or Wi-Fi networks. However, these communications systems may not be available or may fail during natural disasters and emergency situations. Therefore, there is an need for an independent communication system that can operate without relying on conventional network infrastructure .This project presents the design and development of a long-range communication system capable of transmitting

messages upto the distance of 10 kilometers without using SIM cards, internet connectivity, and Wi-Fi networks. This proposed system uses an Arduino Nano as microcontroller and LoRa module for low-power long-range communication and other components like keypad for typing messages or for sending replies and also an OLED(Organic Light Emitting Diode) Display for displaying received messages. Here LoRa technology enables reliable data transmission over long distances while consuming minimal power, making it suitable for portable communication systems. The developed system allows text messages to be transmitted and received between two units using a dedicated wireless channel. The proposed solution provides cost-effective, energy-efficient, and portable communication system that can be applied in rural areas, disaster-affected areas, and other environments where traditional communications system fails or unavailable.

II. SYSTEM OVERVIEW

The 10 km Communication System without SIM, Internet, or Wi-Fi is designed to enable long-range wireless communication between two devices in areas where conventional communication infrastructure is unavailable or fails. The system allows users to transmit text messages over long distances using dedicated wireless communication technology. The main components of the system include an Arduino Nano as microcontroller, LoRa communication modules, display interface, power supply unit, and a voltage regulator circuit for stable operation of the communication module.

In the transmitter section, the Arduino Nano microcontroller processes the input message and sends the data to the LoRa module for wireless transmission.

The LoRa module converts the digital data into radio frequency signals and transmits them over a long distance. On the receiver side, another LoRa module receives the transmitted signal and forwards the data to the Arduino Nano microcontroller for further processing. The microcontroller then displays the received message on the connected display interface, allowing the user to read the transmitted information. Since LoRa modules operate at a lower voltage level, a voltage regulator is used to provide a stable power supply for reliable communication. The entire system operates independently without relying on SIM cards, internet services, or Wi-Fi networks. The proposed system provides a low-power, reliable, and cost-effective communication solution that can be useful in applications such as rural communication, disaster management, emergency response operations, and remote area communication where traditional communication networks are unavailable.

III. PROBLEM STATEMENT

Communication is very important for sharing information between people and systems. Today, most communication methods such as mobile phones, internet services, and Wi-Fi networks are commonly used to send messages and exchange data. However, these systems depends on network infrastructure like cellular towers and internet connectivity to work properly.

In many places such as rural areas, forests, mountains, and other remote locations, these communication facilities may not be available or the network coverage may be very weak. Because of this, people living or working in these areas face difficulties in sending important information over long distances.

Another serious problem occurs during natural disasters such as floods, earthquakes, and storms. In these situations, communication networks can become damaged or stop working completely. When communication is not available, it becomes difficult for people to share important information, coordinate rescue activities, or send emergency messages.

Therefore, there is a need for a communication system that can work independently without using SIM cards, internet services, or Wi-Fi networks. Such a system should be able to send messages over long distances with low power consumption and should remain reliable even in remote areas or emergency situations

where normal communication systems are not available or fails.

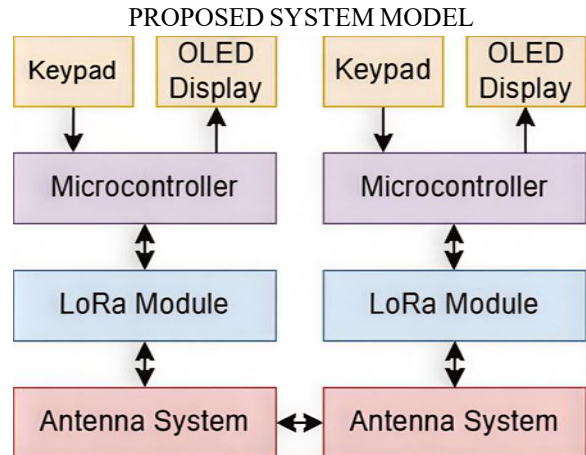

FLOWCHART

“10 km Communication System without using SIM, Internet, or Wi-Fi”

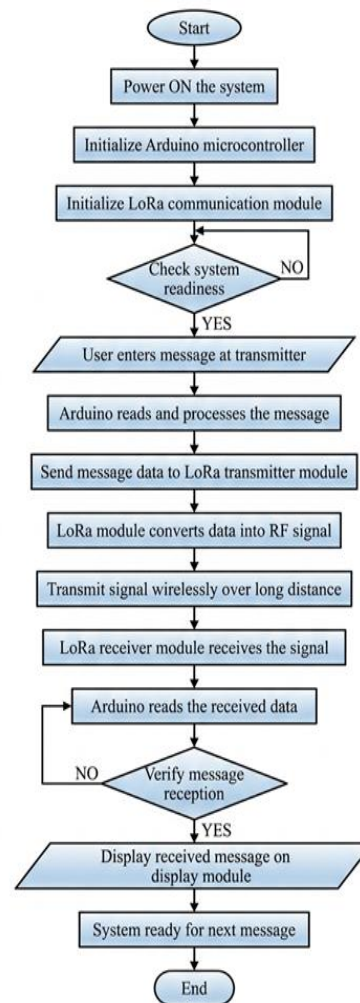

IV. RESULT OF IMPLEMENTATION



V. ADVANTAGES

1. No internet required
2. No SIM card needed
3. Long-range communication
4. Low power consumption
5. Cost-effective solution
6. Simple design
7. Reliable communication
8. Easy implementation
9. Portable system
10. Wireless communication

VI. CONCLUSION

The developed communication system shows that long-range message transmission can be achieved without using SIM cards, internet, or Wi-Fi. The system successfully demonstrates wireless communication using LoRa technology and Arduino. The results indicate that reliable communication over long distances can be achieved with low power consumption and simple hardware.

This project proves that a simple and low-cost communication system can be useful in areas where conventional communication networks are not available or may fail sometimes. The system can support communication in remote locations and emergency situations where reliable connectivity is

required. Therefore, the proposed system provides an effective and practical solution for long-range wireless communication.

REFERENCES

- [1] A. Augustin, J. Yi, T. Clausen, and W. Townsley, "A Study of LoRa: Long Range and Low Power Networks for the Internet of Things," *Sensors*, vol. 16, no. 9, pp. 1–18, 2016.
- [2] U. Raza, P. Kulkarni, and M. Sooriyabandara, "Low Power Wide Area Networks: An Overview," *IEEE Communications Surveys & Tutorials*, vol. 19, no. 2, pp. 855–873, 2017.
- [3] F. Adelantado, X. Vilajosana, P. Tuset-Peiró, B. Martinez, J. Melia-Segui, and T. Watteyne, "Understanding the Limits of LoRaWAN," *IEEE Communications Magazine*, vol. 55, no. 9, pp. 34–40, 2017.
- [4] J. petajarvi, K. Mikhaylov, A. Roivainen, T. Hänninen, and M. Pettissalo, "On the Coverage of LPWANs: Range Evaluation and Channel Attenuation Model for LoRa Technology," *International Conference on ITS Telecommunications*, pp. 55–59, 2015.
- [5] J. Haxhibeqiri, I. Moerman, and J. Hoebeke, "LoRa Scalability: A Simulation Model Based on Interference Measurements," *Sensors*, vol. 17, no. 6, pp. 1–15, 2017
- [6] O. Georgiou and U. Raza, "Low Power Wide Area Network Analysis: Can LoRa Scale?" *IEEE Wireless Communications Letters*, vol. 6, no. 2, pp. 162–165, 2017