

Sensor Based Automatic Street Light Control System

Dr.R.S.Karthik¹ Mr. Dineshkumar.E²

¹Assistant Professor, Department of Computer Science, Hindusthan College of Arts & Science

²II M.Sc. Computer Science, Hindusthan College of Arts & Science, Coimbatore

Abstract: - This paper aims at designing and executing the advanced development in embedded systems for energy saving of street lights. Nowadays, human has become too busy, and is unable to find time even to switch the lights wherever not necessary. The present system is like; the street lights will be switched on in the evening before the sun sets and they are switched off the next day morning after there is sufficient light on the roads. this paper gives the best solution for electrical power wastage. Also the manual operation of the lighting system is completely eliminated. In this paper the two sensors are used which are Light Dependent Resistor LDR sensor to indicate a day/night time and the photoelectric sensors to detect the movement on the street. the microcontroller PIC16F877A is used as brain to control the street light system, where the programming language used for developing the software to the microcontroller is C-language. Finally, the system has been successfully designed and implemented as prototype system.

Key-Words: - Street light, LDR, photoelectric sensor, microcontroller, energy saving and circuit design

1 INTRODUCTION

The idea of designing a new system for the streetlight that do not consume huge amount of electricity and illuminate large areas with the highest intensity of light is concerning each engineer working in this field. Providing street lighting is one of the most important and expensive responsibilities of a city. Lighting can account for 10–38% of the total energy bill in typical cities worldwide [1]. Street lighting is a particularly critical concern for public authorities in developing countries because of its strategic importance for economic and social stability. Inefficient lighting wastes significant financial resources every year, and poor lighting creates unsafe conditions. Energy efficient technologies and design mechanism can reduce cost of the street lighting drastically.

Manual control is prone to errors and leads to energy wastages and manually dimming during mid night is impracticable. Also, dynamically tracking the light level is manually impracticable. The current trend is the introduction of automation and remote management solutions to control street lighting [2].

There are various numbers of control strategy and methods in controlling the street light system such as design and implementation of CPLD based solar power saving system for street lights and automatic traffic controller [1], design and fabrication of automatic street light control system [3], automatic street light intensity control and road safety module using embedded system [4], automatic street light control system [5], Intelligent Street Lighting System Using Gsm [6], energy consumption saving solutions based on intelligent street lighting control system [7] and A Novel Design of an Automatic Lighting Control System for a Wireless Sensor Network with Increased Sensor Lifetime and Reduced Sensor Numbers [8].

In this paper two kinds of sensors will be used which are light sensor and photoelectric sensor. The light sensor will detect darkness to activate the ON/OFF switch, so the streetlights will be ready to turn on and the photoelectric sensor will detect movement to activate the streetlights. LDR, which varies according to the amount of light falling on its surface, this gives an induction for whether it is a day-night time, the photoelectric sensors are placed on the side of the road, which can be controlled by microcontroller PIC16f877A. The photoelectric will be activated only on the night time. If any object crosses the photoelectric beam, a particular light will be automatically ON. By using this as a basic principle, the intelligent system can be designed for the perfect usage of streetlights. The block diagram of street light system as shown in Fig. 1 consists of microcontroller, LDR, and photoelectric sensor. By using the LDR we can operate the lights, i.e. when the light is available

then it will be in the OFF state and when it is dark the light will be in ON state, it means LDR is inversely proportional to light. When the light falls on the LDR it sends the commands to the microcontroller that it should be in the OFF state then it switch OFF the light, the photoelectric sensor will be used to turn ON or OFF the light according to the presence or absent of the object. All these commands are sent to the controller then according to that the device operates. We use a relay to act as an ON/OFF switch.

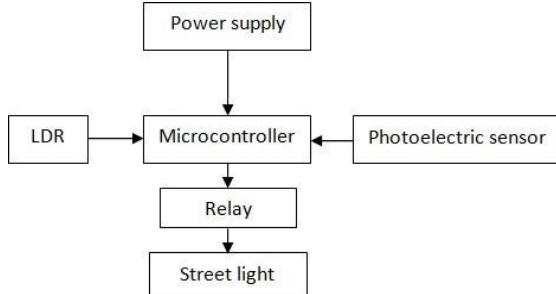

Fig. 1 Block diagram of street light system

II. AUTOMATIC STREET LIGHT SYSTEM CIRCUIT DESIGN

The system basically consists of a LDR, Photoelectric sensor, Power supply, Relays and Micro controller.

2.1 LDR

The theoretical concept of the light sensor lies behind, which is used in this circuit as a darkness detector. The LDR is a resistor as shown in Fig. 2, and its resistance varies according to the amount of light falling on its surface. When the LDR detect light its resistance will get decreased, thus if it detects darkness its resistance will increase.

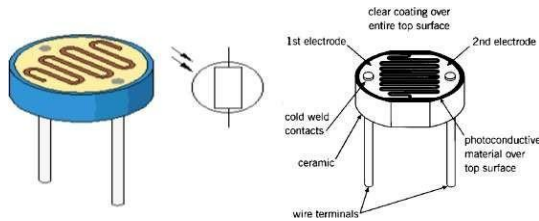

Fig. 2 LDR

2.2 Photoelectric Sensor

To detect the movement in the street, the photoelectric sensors have been used in this paper, where emitter and receiver are in one unit as shown in Fig 3. Light from the emitter strikes the target and the reflected light is diffused from the surface at all angles. If the receiver

receives enough reflected light the output will switch states. When no light is reflected back to the receiver the output returns to its original state. In diffuse scanning the emitter is placed perpendicular to the target. The receiver will be at some angle in order to receive some of the scattered (diffuse) reflection. The photoelectric sensor specifications are illustrated in Table 1.



Fig. 3 Photoelectric sensor

Table 1 Photoelectric sensor specifications

Photoelectric Sensors (MC005)	
Sensing range	3-80 cm
Sensing object	Translucency, opaque
Supply voltage, current	DC 5V, 100mA
Output operation	Normally open
Output	DC three-wire system (NPN)
Diameter, Length	18mm, 45mm
Ambient temperature	-25_70

2.3 Regulated Power Supply

Usually, we start with an unregulated power supply ranging from 9volt to 12volt DC. To make a 5volt power supply, KA8705 voltage regulator IC as shown in Fig. 4 has been used.

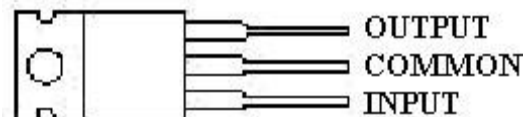

Fig. 4 Power supply regulator

The KA8705 is simple to use. Simply connect the positive lead form unregulated DC power supply (anything from 9VDC to 24VDC) to the input pin,

connect the negative lead to the common pin and then turn on the power, a 5 volt supply from the output pin will be gotten.

2.4 Relays

Relays are remote control electrical switches that are controlled by another switch, such as a horn switch or a computer as in a power train control module. Relays allow a small current flow circuit to control a higher current circuit. Several designs of relays are in use today, 3-pin, 4-pin, 5-pin, and 6-pin, single switch or dual switches. Relays which come in various sizes, ratings, and applications, are used as remote control switches. Fig. 5 shows different types of relays. In this paper, the 4-pin relay will be used.



Fig. 5 Different types of relays

2.5 PIC16F877A Microcontroller

A microcontroller is a computer control system on a single chip. It has many electronic circuits built into it, which can decode written instructions and convert them to electrical signals. The microcontroller will then step through these instructions and execute them one by one. As an example of this a microcontroller we can use it to controller the lighting of a street by using the exact procedures.

Microcontrollers are now changing electronic designs. Instead of hard wiring a number of logic gates together to perform some function we now use instructions to wire the gates electronically. The list of these instructions given to the microcontroller is called a program. There are different types of microcontrollers, this project focuses only on the PIC16F877A Microcontroller where it's pins as shown in Fig. 6.

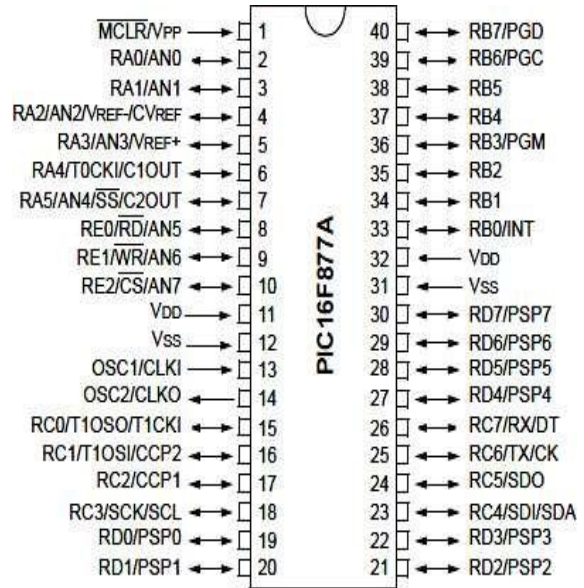

Fig. 6 Pin diagram of PIC16F877A microcontroller

II. AUTOMATIC STREET LIGHT CONTROL CIRCUIT DESIGN

The inputs in the streets lighting system are LDR and photoelectric sensors, after dusk the light sensor will activate the system, to be ready to detect any object by photoelectric sensors, on the road to turn ON the streetlights. Lamps will be used as streetlights in this paper.

In this section each circuit, which has been designed will be discussed. Firstly, the LDR circuit as shown in Fig. 7, the LDR and RV_1 form one arm of the bridge, and R_1 - R_2 form the other arm. These arms can actually be regarded as potential dividers, with the R_1 - R_2 arm applying a fixed half-supply voltage to the non-inverting input of the op-amp, and with the LDR- RV_1 divider applying a light- dependent variable voltage to the inverting terminal of the opamp.

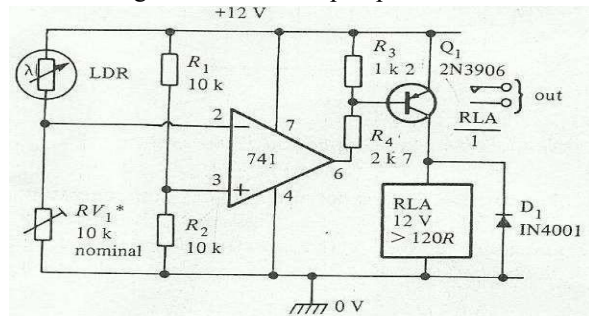

Fig. 7 LDR circuit

In use, RV_1 is adjusted so that the LDR- RV_1 voltage rises fractionally above that of R_1 - R_2 as the light

intensity rises to the desired trigger level, and under this condition the op-amp output switches to negative saturation and thus drives the relay on via Q_1 and biasing resistors R_3 - R_4 when the light intensity falls below this level, the op-amp output switches to positive saturation. The circuit is very sensitive, being able to detect light-level changes too small to be seen by the human eye, the circuit can be modified to act as a precision dark-activated switch by either transposing the inverting and non-inverting input terminals of the op-amp, or by transposing RV_1 and the LDR.

Further, the Reset circuit is used to put the microcontroller into known state. Normally when a PIC microcontroller is reset, execution starts from address 0 of the program memory. Also, the oscillator circuit has been used to provide a microcontroller with a clock, so that the microcontroller can execute a program.

Four photoelectric sensors are used in this paper. Their function to sense the objective that will pass through the street, at the same time give a signal to the microcontroller to turn on the lamp. The idea to save the energy, where the system have been designed to light ON the lamp in the night only and only if there is any object passes through the street. Except to that the light will be OFF. First photoelectric sensor is used to turn ON the first lighting column via microcontroller automatically when any object passes in front of it. Meanwhile the second photoelectric sensor will turn ON the second lighting column and turn OFF the first one after few delay when the object passes in front of it. The third sensor will activate the third lighting column when the object passes in front of it, and will turn OFF the second lighting column after few delays.

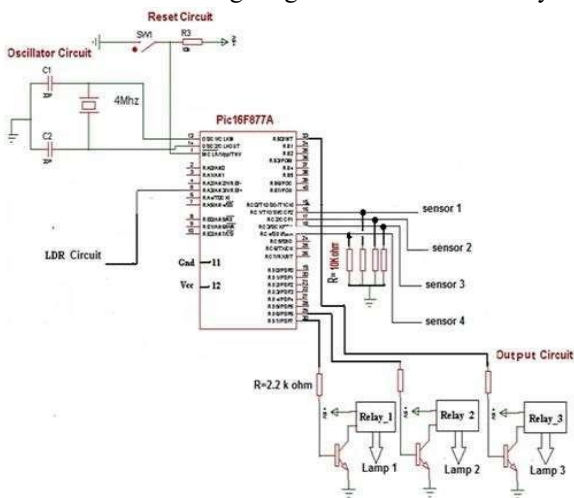

Fig. 8 Schematic circuit of the street light system Finally the last sensor which will be used to turn OFF the third lighting column after the object passes in front of it. Fig. 8 shows the overall system schematic circuit that has been designed in this paper to control the street lights using PIC microcontroller.

The details of this circuit can be summarized as follow:

1. Pins 13 & 14 of the PIC are connected to the Oscillator circuit and Crystal which consisting of 4 MHz crystal connected to two 33 Pf capacitors.
2. Pin 1 is connected to VCC +5V through 10KΩ resistor, connected to reset bottom for resetting the circuit.
3. Pin 5 is connected to the LDR Circuit.
4. Pins 16, 17, 18, and 19 connected to the photoelectric sensors through 10KΩ resistor.
5. Pins 29, 30 and 33 connected to the lamp1, lamp2 and lamp3, through 2.2KΩ resistance and transistor and Relay.

IV.RESULTS AND DISCUSSIONS

The project aims were to reduce the side effects of the current street lighting system, and find a solution to save power. In this project the first thing to do, is to prepare the inputs and outputs of the system to control the lights of the street. The prototype as shown in Fig. 9 has been implemented and works as expected and will prove to be very useful and will fulfill all the present constraints if implemented on a large scale.

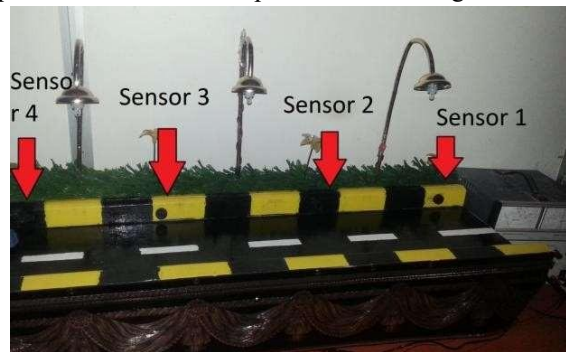

Fig.9 Prototype of street light system

Fig. 9 shows the street light system, from the figure it can be seen that, all lighting column are OFF, because there is no any object passes through the street, even though the weather is night. This is the idea of using the microcontroller to control each lighting column

alone. When any object passes in front specific photoelectric sensor the lighting column which connected to it will be turn ON automatically.

V.CONCLUSION

This paper elaborates the design and construction of automatic street control system circuit. Circuit works properly to turn street lamp ON/OFF. After designing the circuit which controls the light of the street as illustrated in the previous sections. LDR sensor and the photoelectric sensors are the two main conditions in working the circuit. If the two conditions have been satisfied the circuit will do the desired work according to specific program. Each sensor controls the turning ON or OFF the lighting column. The street lights have been successfully controlled by microcontroller. With commands from the controller the lights will be ON in the places of the movement when it's dark. furthermore, the drawback of the street light system using timer controller has been overcome, where the system depends on photoelectric sensor. Finally, this control circuit can be used in a long roadway between the cities.

REFERENCES

- [1] Rajput KY, Khatav G, Pujari M, Yadav P. Intelligent Street lighting system using GSM. International Journal of Engineering Science Invention. 2013; 2(3):60-69.
- [2] Innocent A. Design and Construction of an Automatic Streetlight Controller, design-and-construction-of-an-automaticstreet-light-controller2.html; 2019 [accessed 13 October 2019].
- [3] Akaeze A. Lagos blind streetlight, <https://jigc.media/stories/tech/lagos-blind-street-lights/>; 2018 [Accessed 14 November 2019]
- [4] Kadirova SY, Kajtsanov DI. A real time street lighting control system. In 2017 15th International Conference on Electrical Machines, Drives and Power Systems (ELMA), 2017, pp.174-178
- [5] Saad M, Farij A, Salah A, Abdaljalil A. Automatic Street light system using microcontroller. In 1st International Conference on Machine Design and Automation, 2013, 92-96.
- [6] D. A. Devi and A. Kumar, Design and Implementation of CPLD based Solar Power Saving System for Street Lights and Automatic Traffic Controller, International Journal of Scientific and Research Publications, Vol. 2, Issue11, November 2012.
- [7] J.Mohelnikova, Electric Energy Savings and Light Guides, Energy& Environment, 3rd IASME/WSEAS International Conference on, Cambridge, UK, February 2008, pp.470-474.
- [8] M. A. Wazed, N. Nafis, M. T. Islam and A. S. M. Sayem, Design and Fabrication of Automatic Street Light Control System, Engineering e-Transaction, Vol. 5, No. 1, June 2010, pp 27-34.
- [9] R. Priyasree, R. Kauser, E. Vinitha and N. Gangatharan, Automatic Street Light Intensity Control and Road Safety Module Using Embedded System, International Conference on Computing and Control Engineering, April 2012.
- [10] K. S. Sudhakar, A. A. Anil, K. C. Ashok and S. S. Bhaskar, Automatic Street Light Control System, International Journal of Emerging Technology and Advanced Engineering, Vol. 3, May 2013, PP. 188-189.
- [11] K.Y. Rajput, G. Khatav, M. Pujari, P. Yadav, Intelligent Street Lighting System Using Gsm, International Journal of Engineering Science Invention, Vol2, Issue 3, March 2013, PP. 60- 69.
- [12] M. Popa, C. Cepișcă, Energy Consumption Saving Solutions Based on Intelligent Street Lighting Control System. U.P.B. Sci. Bull., Vol. 73, April 2011, PP. 297-308.
- [13] R. Mohamaddoust, A. T. Haghghat, M. J. M. Sharif and N. Capanni, A Novel Design of an Automatic Lighting Control System for a Wireless Sensor Network with Increased Sensor Lifetime and Reduced Sensor Numbers, Sensors, Vol. 11, PP. 8933-8952.
- [14] L. Jasio, T. Wilmshurst, D. Ibrahim, J. Morton, M. Bates, J. Smith D. Smith and C. Hellebuyck, PIC Microcontrollers: know it all, Publishing Elsevier Science, 2008.