

Solar and Wind Based Micro Grid Energy Monitoring and Management System Using Arduino UNO

Mr. Vara Prasad K.S.B¹, Mr. Ganesh Buridi², Mr. Narayana Rao Kolagani³, Navya Teja Jerripothula⁴,
Vasanth Mokara⁵, Ayyappa Swamy Saragadam⁶, Srinu Mekala⁷, Anitha Moturu⁸

¹ Associate Professor, Dept of Electrical and Electronics Engineering (EEE), Visakha Institute of Engineering & Technology (A), Visakhapatnam, Andhra Pradesh, India

^{2,3} Assistant Professor, Dept of Electrical and Electronics Engineering (EEE), Visakha Institute of Engineering & Technology (A), Visakhapatnam, Andhra Pradesh, India

^{4, 5,6,7,8} Student, Dept of Electrical and Electronics Engineering (EEE), Visakha Institute of Engineering & Technology (A), Visakhapatnam, Andhra Pradesh, India

Abstract- The growing demand for sustainable energy solutions has accelerated the development of hybrid renewable energy systems that can operate efficiently under varying environmental conditions. Conventional standalone systems often rely on a single energy source and lack intelligent mechanisms for monitoring and control, which limits their reliability and performance. This work presents the design and implementation of a hybrid microgrid system that integrates solar and wind energy sources with an embedded monitoring and management framework. The system employs an MPPT-based charge controller to enhance energy extraction and utilizes a battery storage unit supported by a supercapacitor to address fluctuations in load demand. An Arduino Uno serves as the central controller, continuously acquiring voltage and current data through appropriate sensing modules. Based on real-time analysis of battery conditions, the system performs automated load control using a relay mechanism to prevent deep discharge and ensure safe operation. In addition, an ESP8266 WiFi module enables remote monitoring by transmitting system parameters to a cloud interface. Experimental observations demonstrate stable performance, effective energy utilization, and improved system reliability. The proposed approach offers a compact and cost-effective solution suitable for small-scale microgrid and off-grid applications.

Index Terms -Hybrid Microgrid, Renewable Energy, Arduino Uno, Energy Monitoring, MPPT Controller, IoT, ESP8266, Battery Management

I. INTRODUCTION

The increasing global demand for electrical energy, coupled with the environmental impact of conventional fossil fuel-based generation, has accelerated the transition toward renewable energy sources. Among these, solar and wind energy have emerged as the most widely adopted alternatives due to their availability, sustainability, and minimal environmental footprint. However, the intermittent nature of these sources poses significant challenges in maintaining a stable and reliable power supply, particularly in standalone and off-grid applications. To address the variability associated with individual renewable sources, hybrid energy systems have gained considerable attention in recent years. By combining multiple energy sources, such as solar and wind, hybrid systems can provide a more consistent and dependable power output. These systems are especially beneficial in microgrid environments, where localized energy generation and consumption require efficient coordination and management. Despite these advantages, many existing implementations lack intelligent control mechanisms and real-time monitoring capabilities, limiting their overall performance and operational efficiency. Traditional renewable energy systems often operate with minimal automation and rely on basic charge controllers without advanced optimization techniques. In many cases, energy storage units such as batteries are exposed to conditions like overcharging or deep discharge, which significantly reduces their lifespan.

Additionally, the absence of real-time monitoring restricts the ability to track system performance, detect faults, or make informed decisions regarding energy usage. The lack of integration with communication technologies further limits remote accessibility and scalability.

In view of these challenges, there is a clear need for an integrated energy management system that not only combines multiple renewable sources but also incorporates intelligent monitoring, control, and communication features. The objective of this work is to develop a hybrid microgrid energy monitoring and management system using solar and wind energy sources, supported by an embedded control platform. The system is designed to optimize energy utilization, ensure safe operation of storage components, and provide real-time visibility of key electrical parameters. By integrating IoT-based communication, the proposed system also enables remote monitoring, making it suitable for modern smart grid and decentralized energy applications.

II. RELATED WORK

Renewable energy-based microgrid systems have received significant attention in recent years as a sustainable alternative to conventional power generation. The increasing need for clean and reliable energy has driven extensive research in solar photovoltaic and wind energy systems, both as standalone units and in hybrid configurations, to enhance energy availability and system performance [6], [19].

Initial developments in solar energy systems primarily focused on standalone photovoltaic setups integrated with basic charge controllers for battery charging. Although such systems are simple and cost-effective, their performance is highly dependent on solar irradiance, which limits their ability to provide continuous power under varying environmental conditions. Research on photovoltaic modeling and system behavior has highlighted these limitations, emphasizing the need for improved energy extraction techniques [2]. Similarly, wind energy systems have been explored as an alternative renewable source; however, their output is inherently inconsistent due to fluctuating wind speeds and environmental variability [4].

To overcome these limitations, hybrid solar-wind energy systems have been proposed, combining the advantages of both sources to improve reliability and reduce intermittency. Studies have shown that hybrid configurations can significantly enhance energy availability compared to standalone systems [18]. However, many of these systems rely on conventional charge control methods, which do not fully utilize the available energy. The absence of Maximum Power Point Tracking (MPPT) techniques in several designs leads to reduced efficiency, as highlighted in comparative studies of MPPT algorithms [3], [5], [16], [17].

Recent advancements have incorporated embedded systems and microcontrollers to enable real-time monitoring of electrical parameters such as voltage and current. These systems provide basic automation and local visualization, improving operational awareness [7]. However, most implementations employ simple threshold-based control strategies that do not adapt to dynamic load variations or environmental changes. In addition, battery storage remains the primary energy buffer in these systems, often resulting in reduced lifespan due to improper charge-discharge cycles.

With the rapid growth of communication technologies, IoT-based monitoring solutions have been introduced to enable remote access and data visualization. These systems allow users to track energy parameters through cloud platforms or web interfaces, improving accessibility and user interaction [11], [12]. Despite these advancements, many existing solutions focus primarily on monitoring rather than incorporating intelligent control mechanisms for energy management and system protection. Furthermore, the lack of fast-response storage elements limits their ability to handle sudden load variations effectively.

Another important aspect highlighted in the literature is the need for integrated energy management in microgrid environments. Several studies have explored centralized and distributed control strategies for optimizing microgrid operation; however, many of these approaches are complex and not suitable for low-cost or small-scale implementations [8], [10], [20]. Additionally, the integration of sensing, control, and communication into a unified framework remains a challenge in practical deployments.

From the reviewed literature, it is evident that most existing systems address individual aspects such as

energy generation, monitoring, or communication independently. There is a clear research gap in developing a unified system that combines hybrid energy generation, efficient power optimization, intelligent load management, advanced storage support, and IoT-based remote monitoring within a single platform.

To address these challenges, the proposed system presents a comprehensive microgrid solution that integrates solar and wind energy sources with MPPT-based optimization, hybrid storage using battery and supercapacitor, and an Arduino-based intelligent control mechanism. In addition, IoT functionality is incorporated using a WiFi module to enable real-time monitoring and automated decision-making, thereby enhancing system efficiency, reliability, and scalability.

III. PROPOSED SYSTEM

The proposed system is designed as a compact hybrid microgrid that integrates solar and wind energy sources with an embedded monitoring and control framework. The architecture focuses on efficient energy generation, optimized storage, intelligent load management, and real-time monitoring. By combining multiple subsystems into a unified platform, the system ensures reliable power supply under varying environmental conditions. The overall architecture of the system is illustrated in Fig. 1.

A. Overall System Description

At the generation level, electrical energy is produced using a solar photovoltaic panel and a wind turbine. These sources operate simultaneously to enhance energy availability and reduce dependency on a single source. Due to the intermittent nature of renewable energy, the generated power is processed through a Maximum Power Point Tracking (MPPT) charge controller, which ensures optimal energy extraction under varying conditions.

The optimized energy is stored in a hybrid storage system consisting of a battery and a supercapacitor. The battery acts as the primary storage unit, while the supercapacitor provides rapid energy support during transient load conditions. This combination improves system stability and reduces stress on the battery.

The monitoring and control operations are handled by an Arduino Uno microcontroller, which continuously receives input from voltage and current sensors. Based on the sensed parameters, the controller evaluates system conditions and determines the appropriate action for load management.

A relay module is used to control the connection of the load. When the battery voltage is within a safe operating range, the relay allows power to be supplied to the load. In contrast, when the voltage drops below a predefined threshold, the relay disconnects the load to prevent deep discharge.

For user interaction and monitoring, a 16x2 LCD display provides real-time information about system parameters. Additionally, an ESP8266 WiFi module enables IoT-based communication, allowing system data to be transmitted to a remote platform for monitoring and analysis.

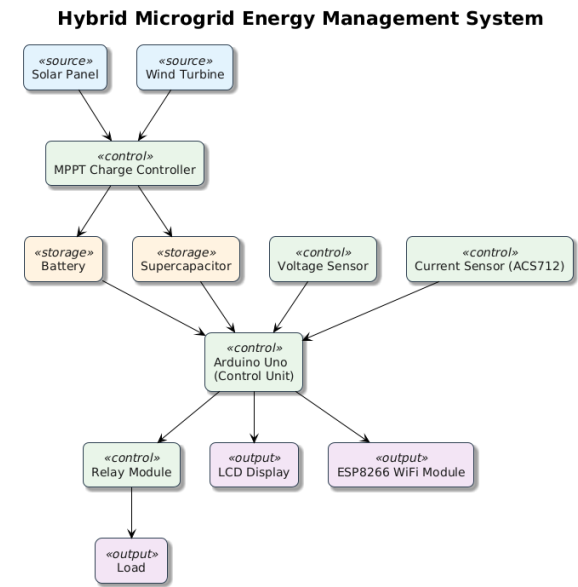

Fig. 1. Block diagram of the proposed solar and wind-based hybrid microgrid energy monitoring and management system.

B. Block Diagram Explanation

As shown in Fig. 1, the system consists of multiple interconnected functional blocks, each responsible for a specific task within the microgrid architecture.

The energy generation block includes the solar panel and wind turbine, which supply power to the system. The MPPT charge controller optimizes the energy output from these sources and directs it to the storage units. The battery and supercapacitor together form the

energy storage subsystem, ensuring both long-term energy availability and rapid response to dynamic load conditions.

The sensing block, consisting of voltage and current sensors, continuously monitors system parameters and provides real-time data to the Arduino controller. The control block processes this data and executes decision-making logic for load management.

The relay module acts as a switching unit that connects or disconnects the load based on control signals from the Arduino. The output section includes both local and remote monitoring units, where the LCD display provides immediate feedback, and the ESP8266 module enables IoT-based data transmission.

C. Hybrid Microgrid Concept

The proposed system operates on the principle of a hybrid microgrid, where multiple renewable energy sources are integrated to provide a reliable and decentralized power supply. Unlike conventional systems that depend on a single energy source, the hybrid approach improves energy availability by compensating for the limitations of individual sources. In this system, solar energy is available during daytime conditions, while wind energy can contribute during periods of low sunlight, thereby ensuring a more consistent power supply. The integration of energy storage further enhances reliability by maintaining supply during periods of low generation.

The addition of intelligent monitoring and control mechanisms transforms the system into a smart microgrid platform. By incorporating IoT capabilities, the system enables real-time performance tracking and remote accessibility, making it suitable for modern energy management applications and future smart grid integration.

IV. PROPOSED SYSTEM

The proposed system integrates multiple hardware modules to achieve efficient energy generation, storage, monitoring, and control. Each component plays a specific role in ensuring reliable and optimized operation of the hybrid microgrid system. The complete hardware interconnection of the system is illustrated in Fig. 2.

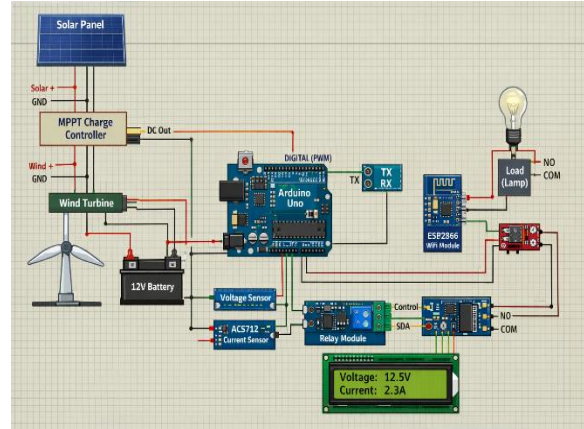

Fig. 2. Circuit diagram of the proposed hybrid microgrid energy monitoring and management system.

- **Arduino Uno:** The Arduino Uno serves as the central control unit of the system. It is based on the ATmega328P microcontroller and is responsible for acquiring data from sensors, processing system parameters, and executing control decisions. The controller continuously monitors voltage and current values and determines the operational state of the load. Its simplicity, low cost, and ease of interfacing make it suitable for embedded energy management applications.
- **Solar Panel:** The solar panel is used to convert sunlight into electrical energy through the photovoltaic effect. It acts as one of the primary energy sources in the system. The output of the solar panel varies depending on solar irradiance and environmental conditions, making it necessary to incorporate efficient energy extraction techniques such as MPPT.
- **Wind Turbine:** The wind turbine converts kinetic energy from wind into electrical energy. It complements the solar panel by generating power under conditions where solar energy may be insufficient. The inclusion of wind energy improves the overall reliability and continuity of power generation in the system.
- **MPPT Charge Controller:** The Maximum Power Point Tracking (MPPT) charge controller plays a critical role in optimizing energy extraction from renewable sources. It dynamically adjusts the operating point of the solar panel and wind system to ensure maximum power output under varying conditions. In addition, it regulates the battery

charging process, preventing overcharging and improving system efficiency.

- **Battery:** The battery acts as the primary energy storage unit in the system. It stores excess energy generated from renewable sources and supplies power to the load when generation is insufficient. Proper battery management ensures stable operation and extends the lifespan of the storage system.
- **Supercapacitor:** A supercapacitor is integrated alongside the battery to handle transient load conditions and sudden power demands. Its ability to charge and discharge rapidly helps stabilize voltage fluctuations and reduces stress on the battery, thereby improving overall system performance.
- **Voltage Sensor Module:** The voltage sensor module is used to measure system or battery voltage in real time. It provides a scaled analog signal to the Arduino, enabling continuous monitoring and supporting protection mechanisms such as preventing deep discharge.
- **Current Sensor (ACS712):** The ACS712 current sensor measures the current flowing through the system using the Hall effect principle. It provides an analog output proportional to the current, allowing accurate monitoring of load consumption and system behavior.
- **Relay Module:** The relay module functions as a switching device to control the load. Based on battery voltage conditions, the Arduino activates or deactivates the relay to connect or disconnect the load, ensuring protection against deep discharge and unsafe operation.
- **ESP8266 WiFi Module:** The ESP8266 module enables wireless communication and IoT functionality. It transmits real-time system parameters such as voltage, current, and load status to a remote platform, enabling monitoring and analysis from any location.
- **16x2 LCD Display:** The 16x2 LCD display provides a local interface for real-time visualization of system parameters. It displays voltage, current, load status, and connectivity information, allowing users to quickly assess system performance.

V. METHODOLOGY

The operation of the proposed hybrid microgrid system is based on the coordinated interaction between energy generation, storage, monitoring, and control units. The methodology focuses on ensuring efficient energy utilization, stable system performance, and protection of storage components through intelligent decision-making.

A. System Operation

The system begins with energy generation from two renewable sources, namely the solar panel and the wind turbine. These sources operate simultaneously, producing electrical energy under varying environmental conditions. The generated power is directed to an MPPT charge controller, which continuously adjusts the operating point to maximize energy extraction.

The optimized output from the charge controller is used to charge the battery, which serves as the primary energy storage unit. In parallel, a supercapacitor is connected to support the system during transient conditions. When there is a sudden increase in load demand, the supercapacitor provides immediate energy, thereby maintaining voltage stability and reducing stress on the battery.

Voltage and current sensors are deployed within the system to monitor key electrical parameters in real time. The sensed analog signals are fed into the Arduino Uno, where they are processed and evaluated. This continuous monitoring enables the system to make informed decisions regarding load management and system safety.

B. Step-by-Step Working

The working sequence of the system can be described as follows:

- The solar panel and wind turbine generate electrical energy based on environmental conditions.
- The generated energy is routed through the MPPT charge controller for optimal power extraction.
- The optimized energy is stored in the battery, while the supercapacitor remains available for transient support.

- The voltage sensor measures the battery voltage, and the current sensor monitors load current.
- Sensor data is transmitted to the Arduino Uno for processing.
- The controller continuously compares the battery voltage with predefined threshold values.
- If the battery voltage is within the safe operating range, the relay is activated to supply power to the load.
- If the battery voltage falls below the threshold level, the relay is deactivated to disconnect the load and prevent deep discharge.
- The system parameters, including voltage, current, load status, and connectivity, are displayed on the LCD.
- The ESP8266 module transmits real-time data to a remote platform for monitoring and analysis.

C. System Flow

The overall flow of the system follows a structured sequence from energy generation to load control and monitoring, as shown in Fig. 3.

This sequential flow ensures that each stage of the system operates in coordination, maintaining efficiency and reliability.

Flowchart of Hybrid Microgrid Energy Monitoring and Control

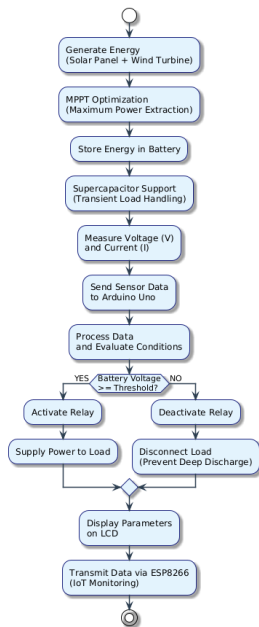

Fig. 3. Flowchart of the operational methodology and control logic of the proposed system

D. System Flow

The control logic of the system is centered on battery voltage monitoring and protection. The Arduino Uno implements a threshold-based decision mechanism to regulate load operation. This logic ensures that the battery is neither over-discharged nor subjected to unsafe operating conditions.

- When the battery voltage is above the predefined safe limit, the system allows normal operation, and the load remains connected.
- When the battery voltage drops below the threshold, the controller disconnects the load using the relay module.
- The system continuously monitors voltage levels, allowing automatic reconnection of the load once the battery is recharged to a safe level.

This control strategy enhances the lifespan of the battery, ensures system safety, and maintains consistent performance. The integration of real-time monitoring and automated decision-making transforms the system into an intelligent energy management solution.

VI. RESULTS AND DISCUSSION

The performance of the proposed hybrid microgrid system was evaluated under varying operating conditions to analyze its effectiveness in energy monitoring, load control, and system stability. The results were obtained through real-time observation of voltage, current, and load behavior, along with data visualization using local display and IoT-based monitoring.

A. Voltage Observations

The battery voltage was continuously monitored to assess the charging and discharging characteristics of the system. During periods of sufficient solar irradiance and wind availability, the battery voltage showed a steady increase, indicating efficient energy generation and storage. The MPPT charge controller ensured optimal power utilization, thereby improving charging efficiency. Under reduced generation conditions, the battery voltage gradually decreased as the load consumed energy from the storage unit. The implemented threshold-based control mechanism maintained the voltage within safe limits, preventing deep discharge and ensuring reliable operation.

B. Current Observations

The current sensor provided real-time measurements of load consumption. It was observed that the current varied according to the connected load conditions. Stable readings indicated consistent energy delivery, while transient variations were effectively compensated by the supercapacitor. During sudden load changes, the supercapacitor supplied immediate current, minimizing fluctuations and enhancing voltage stability. This behavior reduced stress on the battery and improved overall system performance.

C. Load Behavior

The load operation was governed by the battery voltage and the implemented control logic. When the battery voltage remained above the predefined threshold, the relay module maintained the load in an active state. When the voltage dropped below the critical level, the relay automatically disconnected the load to protect the battery. This automated switching mechanism ensured safe and reliable system operation. The system also demonstrated automatic reconnection of the load once the battery voltage returned to a safe level.

D. Display and System Implementation

The practical implementation of the proposed system is shown in Fig. 5, where all hardware components including the Arduino Uno, sensors, relay module, solar panel, and load are integrated and functioning. The real-time system parameters are displayed on the 16x2 LCD module, as shown in Fig. 6, which provides continuous feedback on current and input values during operation.

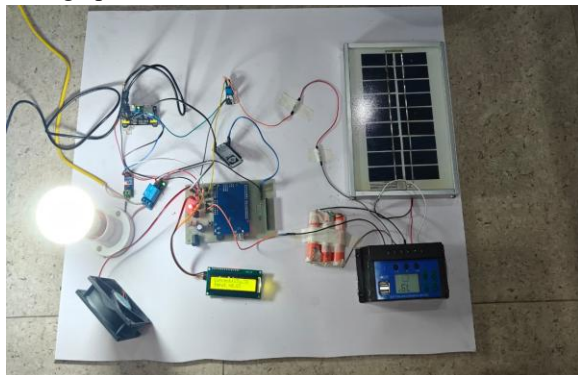

Fig. 5. Experimental setup of the proposed hybrid microgrid energy monitoring and management system.



Fig. 6. Real-time current and input values displayed on the 16x2 LCD module.

E. Performance Analysis

The experimental results confirm that the proposed system effectively integrates hybrid renewable energy sources with intelligent monitoring and control. Key observations include:

- Improved energy utilization through combined solar and wind generation
- Enhanced efficiency using MPPT-based optimization
- Stable voltage regulation supported by the supercapacitor
- Reliable load management through automated relay control
- Real-time monitoring via LCD display

The system maintained consistent performance under different operating conditions, demonstrating its capability to balance energy generation, storage, and consumption effectively. The integration of automation and real-time monitoring enhances system reliability and usability.

F. Performance Analysis

To further validate the performance of the proposed system, key electrical parameters observed during experimental testing are summarized in Table I. The recorded values represent the system behavior under different operating conditions, including variations in energy generation and load demand.

Table I: Experimental Performance Parameters

Parameter	Observed Value	Description
Battery Voltage	11.8V – 13.2V	Charging/Discharging Range
Load Voltage	~12V	Stable Output Voltage

Current Consumption	0.5A – 2.5A	Depending on Load
MPPT Efficiency	90% – 95%	Optimized Power Extraction
Relay Status	ON / OFF	Based on Voltage Threshold
LCD Display Output	Real-time	Voltage & Current Display
IoT Transmission	Active	Data sent via ESP8266
Response Time	< 2 seconds	Relay Switching Delay

The battery voltage was maintained within a safe operating range during both charging and discharging cycles, confirming the effectiveness of the implemented control strategy. The load voltage remained stable, indicating reliable power delivery to the connected load. The current consumption varied depending on load conditions, demonstrating the system’s ability to adapt to dynamic energy requirements.

The MPPT charge controller contributed to improved energy extraction efficiency, while the relay module operated accurately based on predefined voltage thresholds. The system also exhibited a fast response time in switching operations, ensuring protection against unfavorable conditions such as deep discharge. Furthermore, real-time monitoring through the LCD display and IoT communication via the ESP8266 module confirmed continuous system visibility and data accessibility. These observations indicate that the proposed system operates efficiently, maintains stability, and effectively integrates renewable energy sources with intelligent monitoring and control mechanisms.

VII. ADVANTAGES

The proposed hybrid microgrid system offers several advantages in terms of efficiency, reliability, and intelligent energy management. The integration of renewable sources with embedded control and communication enhances overall system performance.

- Improved Energy Efficiency: The use of both solar and wind energy sources ensures better utilization of available renewable resources. The incorporation of an MPPT charge controller further enhances efficiency by extracting

maximum power under varying environmental conditions. This reduces energy loss and improves overall system output.

- Automated Operation: The system operates with minimal human intervention due to the implementation of an embedded control mechanism. The Arduino-based controller continuously monitors system parameters and automatically manages load operation based on battery conditions. This automation simplifies system management and increases operational reliability.
- Battery Protection: Battery health is maintained through intelligent control logic that prevents deep discharge and unsafe operating conditions. By disconnecting the load when the battery voltage drops below a predefined threshold, the system extends battery lifespan and ensures safe operation of the storage unit.
- IoT-Based Monitoring: The integration of the ESP8266 WiFi module enables real-time remote monitoring of system parameters. Users can access data such as voltage, current, and load status through a cloud platform or mobile interface. This feature improves accessibility, allows performance tracking, and supports timely decision-making.

VIII. APPLICATIONS

The proposed hybrid microgrid energy monitoring and management system can be applied across various domains where reliable, efficient, and sustainable power solutions are required. Its flexibility and integration of renewable sources with intelligent control make it suitable for both small-scale and distributed energy applications.

- Smart Homes and Buildings: The system can be deployed in residential and commercial buildings to support energy-efficient operation. By integrating renewable energy sources with automated load management, it helps reduce dependence on conventional grid power and lowers overall energy consumption.
- Rural Electrification: In remote and rural areas where grid connectivity is limited or unavailable,

the proposed system provides a reliable standalone power solution. The hybrid combination of solar and wind energy ensures better availability of electricity, improving living standards and supporting basic infrastructure.

- **Renewable Energy-Based Microgrids:** The system can be utilized as a core unit in small-scale microgrid installations. Its ability to manage multiple energy sources, storage systems, and loads makes it suitable for decentralized energy networks and community-level power distribution.
- **Backup Power Systems:** The proposed system can function as an efficient backup power source during grid outages. The integration of battery storage and intelligent load control ensures uninterrupted power supply to essential devices while maintaining system safety.

IX. FUTURE SCOPE

The proposed hybrid microgrid system demonstrates a reliable and efficient approach for renewable energy management; however, several enhancements can be incorporated to further improve its functionality, scalability, and intelligence.

- **AI-Based Energy Prediction:** Future work can integrate machine learning techniques to predict energy generation and consumption patterns based on environmental and historical data. Such predictive models can enable proactive energy management, optimize load scheduling, and improve overall system efficiency.
- **Mobile Application Integration:** The system can be extended by developing a dedicated mobile application for real-time monitoring and control. This would provide a user-friendly interface for accessing system data, receiving alerts, and remotely managing load operations, thereby enhancing usability and accessibility.
- **Smart Grid Integration:** The proposed system can be scaled and integrated into larger smart grid infrastructures. By enabling communication between multiple microgrid units, energy sharing and distributed generation can be achieved, improving grid stability and efficiency at a broader level.

- **Advanced Energy Storage Management:** Further improvements can include the implementation of advanced battery management systems (BMS) for precise monitoring of battery health, temperature, and charge cycles. This would enhance safety, extend battery lifespan, and improve system reliability.
- **Enhanced Data Analytics and Cloud Integration:** Future developments may incorporate advanced cloud-based analytics for detailed performance evaluation, fault detection, and optimization. This would enable better decision-making and long-term system planning.

X. FUTURE SCOPE

This work presented the design and implementation of a hybrid microgrid energy monitoring and management system integrating solar and wind energy sources. The system combines efficient energy generation, optimized storage, real-time monitoring, and intelligent control within a unified framework. By incorporating an MPPT-based charge controller, battery and supercapacitor hybrid storage, and an Arduino-based control unit, the system ensures effective utilization of renewable energy under varying operating conditions.

The developed system successfully demonstrates automated load management based on battery voltage levels, thereby preventing deep discharge and enhancing the lifespan of the storage unit. Real-time monitoring of electrical parameters, both locally through an LCD and remotely via an IoT-enabled WiFi module, provides improved visibility and accessibility. The integration of a supercapacitor further contributes to system stability by handling transient load demands.

The key achievements of this work include improved energy efficiency through hybrid source utilization, reliable system operation with automated protection mechanisms, and the implementation of IoT-based monitoring for remote access. The proposed approach offers a cost-effective and scalable solution suitable for small-scale microgrid and off-grid applications.

Overall, the system contributes toward the advancement of sustainable energy solutions by addressing key challenges associated with renewable energy integration and management. It provides a

practical foundation for future development of intelligent and decentralized energy systems aligned with emerging smart grid technologies.

REFERENCES

- [1] W. Stallings, **Cryptography and Network Security: Principles and Practice**, 7th ed. Pearson Education, 2017.
- [2] J. A. Gow and C. D. Manning, "Development of a photovoltaic array model for use in power-electronics simulation studies," **IET Electric Power Applications**, vol. 3, no. 4, pp. 321–328, 2009.
- [3] T. Esum and P. L. Chapman, "Comparison of photovoltaic array maximum power point tracking techniques," **IEEE Transactions on Energy Conversion**, vol. 22, no. 2, pp. 439–449, June 2007.
- [4] S. M. Muyeen, R. Takahashi, and J. Tamura, "Operation and control of HVDC-connected offshore wind farm," **IEEE Transactions on Sustainable Energy**, vol. 1, no. 1, pp. 30–37, Apr. 2010.
- [5] H. Patel and V. Agarwal, "MPPT scheme for a PV-fed single-phase single-stage grid-connected inverter," **IEEE Transactions on Energy Conversion**, vol. 24, no. 1, pp. 256–262, Mar. 2009.
- [6] A. Khaligh and O. C. Onar, **Energy Harvesting: Solar, Wind, and Ocean Energy Conversion Systems**. CRC Press, 2010.
- [7] M. H. Rashid, **Power Electronics: Circuits, Devices, and Applications**, 4th ed. Pearson Education, 2014.
- [8] A. G. Tsikalakis and N. D. Hatziargyriou, "Centralized control for optimizing microgrids operation," **IEEE Transactions on Energy Conversion**, vol. 23, no. 1, pp. 241–248, Mar. 2008.
- [9] D. B. Avancini et al., "Energy meters evolution in smart grids: A review," **Journal of Cleaner Production**, vol. 217, pp. 702–715, 2019.
- [10] V. N. G. J. Soares, F. J. Soares, and P. M. Rocha Almeida, "Distributed energy resource management in smart grids," **Electric Power Systems Research**, vol. 95, pp. 54–62, Feb. 2013.
- [11] R. Want, B. N. Schilit, and S. Jenson, "Enabling the Internet of Things," **Computer**, vol. 48, no. 1, pp. 28–35, Jan. 2015.
- [12] Y. Kim, E. S. Kim, and S. Choi, "A real-time energy monitoring system using IoT," **International Journal of Smart Home**, vol. 10, no. 3, pp. 1–10, 2016.
- [13] A. Dunkels, B. Grönvall, and T. Voigt, "Contiki - a lightweight and flexible operating system for tiny networked sensors," in **Proc. IEEE Local Computer Networks**, 2004, pp. 455–462.
- [14] ACS712 Datasheet, Allegro Microsystems, "Fully Integrated, Hall Effect-Based Linear Current Sensor IC," 2018.
- [15] ESP8266 Datasheet, Espressif Systems, "ESP8266EX WiFi Module Technical Reference," 2020.
- [16] N. Femia, G. Petrone, G. Spagnuolo, and M. Vitelli, "Optimization of perturb and observe maximum power point tracking method," **IEEE Transactions on Power Electronics**, vol. 20, no. 4, pp. 963–973, July 2005.
- [17] S. Jain and V. Agarwal, "A new algorithm for rapid tracking of approximate maximum power point in photovoltaic systems," **IEEE Power Electronics Letters**, vol. 2, no. 1, pp. 16–19, Mar. 2004.
- [18] J. M. Carrasco et al., "Power-electronic systems for the grid integration of renewable energy sources: A survey," **IEEE Transactions on Industrial Electronics**, vol. 53, no. 4, pp. 1002–1016, Aug. 2006.
- [19] H. Lund, "Renewable energy strategies for sustainable development," **Energy**, vol. 32, no. 6, pp. 912–919, 2007.
- [20] M. Pipattanasomporn, H. Feroze, and S. Rahman, "Multi-agent systems in a distributed smart grid: Design and implementation," in **Proc. IEEE Power Systems Conference and Exposition**, 2009, pp. 1–8

ABOUT THE AUTHORS



Mr. Varaprasad K. S. B is the Head of the Department of Electrical and Electronics Engineering at Visakha Institute of Engineering and Technology (A), Visakhapatnam, Andhra Pradesh, India, with over 15 years of teaching experience. He is currently pursuing his Ph.D. and has a strong academic background in electrical engineering. His research interests include power system engineering, electrical machines, smart grid technologies, renewable energy systems, and advanced control techniques. He has guided numerous undergraduate projects and actively contributes to academic and research activities.



Mr. Ganesh Buridi is an Assistant Professor in the Department of Electrical and Electronics Engineering at Visakha Institute of Engineering and Technology (A), Visakhapatnam. His areas of expertise include power electronics, smart grid technologies, and modern electrical systems. She is dedicated to teaching and guiding students in academic and project-based learning. He actively participates in seminars, workshops, and research-oriented activities.



Mr. Narayana Rao Kolagani is an Assistant Professor in the Department of Electrical and Electronics Engineering at Visakha Institute of Engineering and Technology (A), Visakhapatnam. He has significant teaching experience and is actively involved in mentoring undergraduate students. Her areas of interest include power systems, renewable energy systems, and electrical machines. He has guided several student projects and participates in academic activities, workshops, and technical development programs.



Navya Teja Jerripothula is an undergraduate student in the Department of Electrical and Electronics Engineering at Visakha Institute of Engineering and Technology (A), Visakhapatnam. He is actively engaged in academic learning and project development in the field of electrical engineering. His areas of interest include electrical systems, energy management, and smart technologies. He is keen on applying theoretical knowledge to practical engineering solutions.



Vasanth Mokara is an undergraduate student in Electrical and Electronics Engineering at Visakha Institute of Engineering and Technology (A), Visakhapatnam. He has a strong interest in power systems and renewable energy technologies. He actively participates in academic projects and technical activities. He is focused on developing practical skills and innovative solutions in electrical engineering.



Ayyappa Swamy Saragadam is an undergraduate student in Electrical and Electronics Engineering at Visakha Institute of Engineering and Technology (A), Visakhapatnam. His areas of interest include power systems and electrical engineering applications. He actively participates in academic and project-based learning. He is focused on gaining practical knowledge and contributing to innovative engineering solutions.



Srinu Mekala is an undergraduate student in Electrical and Electronics Engineering at Visakha Institute of Engineering and Technology (A), Visakhapatnam. His areas of interest include power systems and electrical engineering applications. He actively participates in academic and project-based learning. He is focused on gaining practical knowledge and contributing to innovative engineering solutions.



Anitha Moturu is an undergraduate student in the Department of Electrical and Electronics Engineering at Visakha Institute of Engineering and Technology (A), Visakhapatnam. Her interests include electrical machines, power systems, and energy applications. She actively engages in project development and technical learning. She is motivated to enhance his knowledge and skills in modern electrical engineering practices.