

Solar Based Wireless Charging

K. Preethi¹, R. Lakshmi Ruthika², K. Srija³, D. Haseena⁴

^{1,2,3,4}Student, Department of Electrical and Electronics Engineering, G Pulla Reddy Engineering College, India

Abstract—Solar Based Wireless Charging is an advanced method used to transfer electrical energy without physical wires. The main objective of this project is to generate electrical energy using solar panel and transfer the energy wirelessly to charge mobile devices using electromagnetic induction principle.

The solar panel converts sunlight into electrical energy which is regulated using DC-DC converter and stored in rechargeable lithium battery. The stored energy is supplied to wireless transmitter circuit which generates high frequency alternating current. The transmitter coil produces magnetic field which induces voltage in receiver coil placed near it. The receiver circuit converts induced current into DC power which is used to charge mobile phone wirelessly.

This project promotes renewable energy usage and reduces dependency on conventional electricity. The system is eco-friendly, portable and suitable for modern electronic devices.

Index Terms—Solar Energy, Wireless Charging, Inductive Coupling, Renewable Energy, Transmitter Coil, Receiver Coil

I. INTRODUCTION

Wireless power transfer technology is widely used in modern electronic devices because it allows charging without physical connection. Traditional wired charging systems require cables which may cause inconvenience and damage. Wireless charging eliminates the need of cables by transferring electrical energy through electromagnetic field.

Solar energy is one of the most abundant renewable energy sources available in nature. It is clean, pollution free and freely available. Combining solar energy with wireless charging technology improves energy efficiency and promotes green energy utilization.

Wireless charging works on electromagnetic induction principle. When alternating current flows through transmitter coil, magnetic field is produced. This

magnetic field induces voltage in receiver coil placed nearby. The induced voltage is converted into DC supply to charge electronic devices such as mobile phones.

II. MATERIAL AND METHODS

Study Design

Experimental project-based study of solar powered wireless energy transfer system.

Components Used

1. Solar Panel (6V, 5W)
2. DC-DC Boost Converter
3. 18650 Lithium Ion Battery (3.7V)
4. Wireless Transmitter Module
5. Transmitter Coil
6. Wireless Receiver Module
7. Receiver Coil
8. Rectifier Circuit
9. Voltage Regulator
10. Mobile Phone Load

Experimental Setup

Solar panel output is connected to DC-DC converter. Converter regulates voltage and charges battery. Battery provides power supply to wireless transmitter circuit. Transmitter coil generates magnetic field which induces voltage in receiver coil. Receiver circuit converts AC signal into DC signal which is used to charge mobile phone wirelessly.

Wireless power transfer system mainly consists of transmitter circuit, receiver circuit and magnetic coupling between coils.

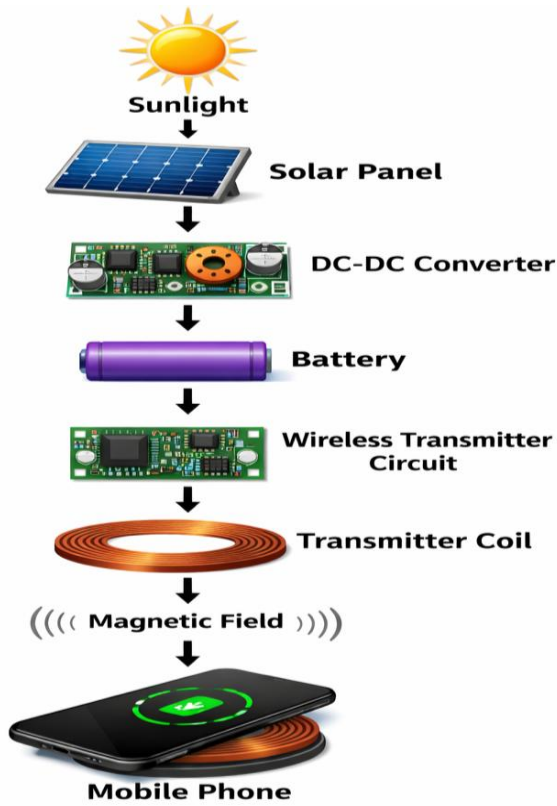

Fig:1 Schematic Diagram

Block Diagram

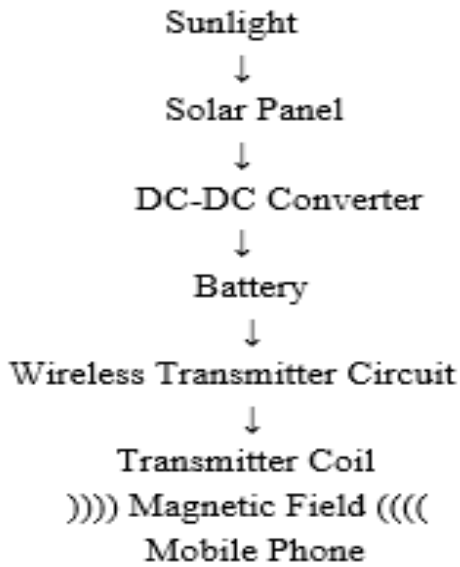

Fig:2

Circuit Diagram

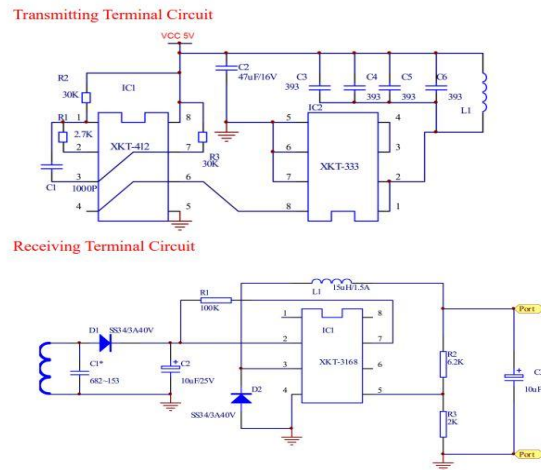

Fig. 3. Circuit Diagram of Wireless Power Transfer Transmitter and Receiver

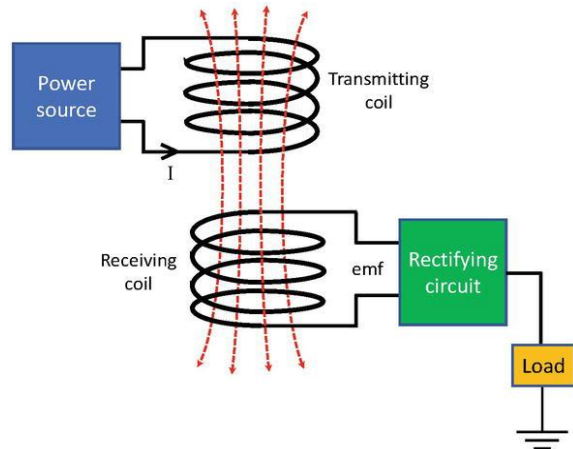

Fig. 4. Block Diagram of Wireless Power Transfer using Inductive Coupling

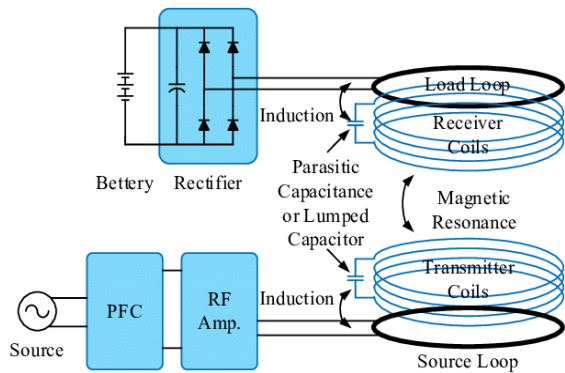

Fig 5. Wireless Power Transfer Using Coupled Coils

Working Principle

Step 1: Solar panel converts sunlight energy into electrical energy.

Step 2: DC-DC converter regulates voltage to required level.

Step 3: Battery stores electrical energy for continuous power supply.

Step 4: Wireless transmitter circuit converts DC supply into high frequency AC signal.

Step 5: Transmitter coil produces alternating magnetic field.

Step 6: Receiver coil captures magnetic flux and induces voltage.

Step 7: Rectifier converts AC signal into DC supply.

Step 8: Regulated DC output is used to charge mobile phone wirelessly.

Inductive coupling is the basic principle used for wireless energy transfer between coils.

- Medical devices
- Industrial automation
- Portable electronic devices
- IoT devices

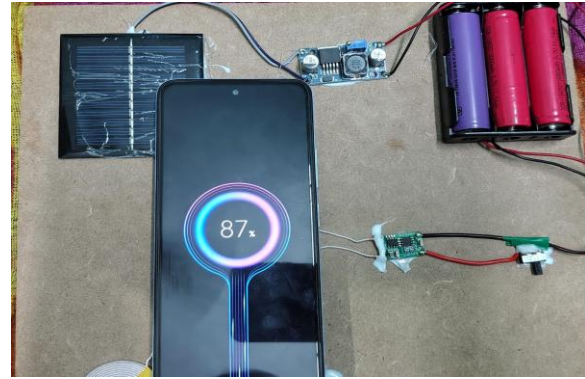

Fig 6. Hardware Implementation of Wireless Power Transfer for Mobile Charging

III. RESULT

The solar based wireless charging system successfully transfers electrical power without wires. The transmitter coil generates magnetic field which induces voltage in receiver coil. The output voltage obtained is approximately 5V which is suitable for charging mobile devices.

Efficiency of wireless power transfer depends on coil alignment and distance between coils. Maximum efficiency is obtained when coils are properly aligned.

Advantages

- Uses renewable solar energy
- Wireless power transfer
- Portable system
- Eco-friendly
- Safe operation
- Modern technology

Disadvantages

- Efficiency is lower compared to wired charging
- Charging distance is limited
- Requires proper alignment of coils
- Charging speed may be moderate

Applications

- Wireless mobile charging
- Electric vehicle charging

IV. DISCUSSION

Wireless charging technology provides convenient charging without cables. Solar energy provides renewable and eco-friendly power source. Combining solar energy with wireless power transfer improves flexibility and portability of charging system.

System performance depends on frequency, coil alignment and distance between coils. Proper design of coils improves efficiency of wireless power transfer.

Wireless charging technology has wide future scope in electric vehicles, biomedical devices and smart electronics.

V. CONCLUSION

Solar based wireless charging system is an efficient and eco-friendly method for transferring electrical energy without wires. The project demonstrates electromagnetic induction principle for wireless power transfer.

The system reduces dependency on conventional electricity and promotes renewable energy usage. This technology can be further improved for fast charging applications in future.

REFERENCES

- [1] Wireless Power Transfer using Inductive Coupling Open Research Paper

- [2] Solar Energy Technology Handbook / Solar Energy Basics
<https://www.intechopen.com/books/solar-radiation>
- [3] Power Electronics – DC-DC Converter
<https://www.mdpi.com/1424-8220/22/15/5573>
- [4] Qi Wireless Charging Standard Qi Standard Details
- [5] Electromagnetic Induction Theory Wireless Power Transfer PDF