

IoT Based Smart Energy Meter with Theft Detection

Mrs. Tapala Mallika¹, Boya chandrasekharnaidu², MULLA ASHRAF SOHAIL³

Kaligar Sunar Mohammed Syed Hussain⁴, Boya Dinesh⁵

^{1,2,3,4,5}*Department of Electronics and Communication Engineering St. John's College of Engineering and Technology, Yerrakota, Yemmiganur, Andhra Pradesh, India*

Abstract—The growing demand for electrical energy and the increasing incidence of power theft have created a need for intelligent and efficient energy monitoring systems. This paper presents an IoT-based Smart Energy Meter with integrated theft detection and load control for real-time monitoring and effective management of electrical energy consumption. The system utilizes an Arduino microcontroller as the primary control unit to measure electrical parameters through a current sensor, voltage sensor, and LDR sensor. These measured parameters—voltage, current, power, and energy consumption—are displayed locally on an LCD.

To enable remote monitoring and data analytics, a NodeMCU (ESP8266) module is incorporated to transmit real-time energy data to a cloud-based IoT platform. Electricity theft is detected by identifying abnormal variations in current and inconsistencies in measured energy data, upon which the system generates alerts through the IoT interface.

The design further includes a relay-based automated load control mechanism that continuously monitors current levels. If the current exceeds a predefined threshold, the relay disconnects the load to prevent overloading and equipment damage. The proposed system provides a low-cost, scalable, and reliable solution suitable for smart grid, residential, and industrial applications.

I. INTRODUCTION

The rapid increase in global electrical energy demand, along with the rising frequency of power theft, has created an urgent need for intelligent and reliable energy monitoring solutions. Traditional electromechanical and digital meters lack real-time measurement, remote accessibility, and automated control mechanisms, limiting their suitability for modern smart grid environments. With advancements in embedded systems and Internet of Things (IoT) technologies, smart energy meters have emerged as an

effective solution for continuous monitoring, data logging, and intelligent decision-making.

This paper presents an IoT-based Smart Energy Meter with Theft Detection and Load Control, developed using an Arduino microcontroller, electrical sensors, and a NodeMCU (ESP8266) module for cloud connectivity. The system measures voltage, current, power, and energy consumption in real time and transmits the data to an IoT platform for remote monitoring and analytics. Electricity theft is detected by analysing abnormal current variations and inconsistencies in measured parameters, enabling the system to generate timely alerts. Additionally, a relay-based load control mechanism automatically disconnects the load when the current exceeds a predefined threshold, thus preventing overload and improving system safety and reliability.

The proposed design integrates embedded hardware and IoT communication to create a low-cost, scalable, and energy-efficient solution suitable for residential, industrial, and smart grid applications. Its ability to detect theft, monitor consumption, and perform automated load management positions it as a viable contribution toward modernizing energy distribution infrastructures.

II. RELATED WORKS

Smart energy metering systems integrated with IoT technologies have been widely explored in recent years to address challenges such as power theft, inaccurate billing, and lack of real-time monitoring. Several researchers have proposed various approaches to enhance the reliability and efficiency of energy consumption monitoring.

Prathiba et al. (2024) developed an IoT-based smart energy meter using Arduino and Wi-Fi connectivity to

enable real-time data transmission and theft detection through abnormal current pattern analysis. Similarly, Al-Ali et al. (2018) introduced a tampering-detection mechanism using IoT and GSM technology, enabling automatic meter reading and alert notifications during unauthorized access.

Karthik et al. (2025) designed an ESP8266-based system employing dual current sensors to compare supply- and load-side currents for accurate theft identification, while Haripriya et al. (2025) utilized PZEM-004T sensors to detect overload and theft in real time and to automatically disconnect unsafe loads through relay control. A prepaid smart energy meter model with IoT support was proposed by Ramesh et al. (2025), integrating tampering detection and automated supply cut-off when credit is exhausted-based monitoring systems were explored by Sharma and Singh (2025), enabling continuous usage tracking and remote load shutdown during abnormal current flow. Pavithra and Balaji (2024) developed a low-cost IoT-based monitoring system aimed at reducing manual meter reading and improving billing transparency. Earlier works by Kumar et al. (2020), Deepak and Arun (2018), and Gupta and Verma (2018) laid foundational concepts for automatic meter reading, tamper detection, and pattern-based theft identification using IoT and GSM technologies.

Overall, existing works emphasize the importance of remote monitoring, anomaly detection, and automated control in modern smart grid systems. However, many systems lack combined support for real-time monitoring, theft detection, and automatic load control within a single integrated platform. The proposed system addresses these gaps by offering a comprehensive IoT-enabled solution that performs continuous monitoring, detects theft, and implements load protection in a cost-effective and scalable manner.

III. LITERATURE REVIEW

The rapid advancement of Internet of Things (IoT) technologies has significantly influenced the development of smart energy metering systems, especially for real-time monitoring and theft detection. Several studies have explored different approaches to implement IoT-based energy management systems with varying features and capabilities.

R. Prathiba et al. [1] proposed an IoT-enabled smart energy meter using Arduino and Wi-Fi technology. Their system enables real-time energy monitoring and theft detection by transmitting consumption data to a cloud server and identifying abnormal current variations, thereby reducing the need for manual inspections.

A. R. Al-Ali et al. [2] developed a smart energy meter integrated with tampering detection using IoT and GSM communication. Their system allows automatic meter reading and sends alerts in case of unauthorized access, improving reliability and minimizing human effort.

S. Karthik et al. [3] presented an energy meter leveraging ESP8266 and dual current sensors for detecting electricity theft. By comparing the load-side and source-side current measurements, the system accurately identifies illegal power usage while enabling remote load control.

V. Haripriya et al. [4] implemented a real-time smart energy monitoring system using Arduino and PZEM-004T sensors. The system detects both overload and theft conditions and automatically disconnects the load using a relay, with continuous updates transmitted to an IoT platform.

P. Ramesh et al. [5] proposed a prepaid smart energy meter with IoT integration and theft detection. The system disconnects power when the prepaid balance is exhausted and identifies meter tampering via sensors and GSM alerts, ensuring accurate billing and preventing unauthorized usage.

M. K. Sharma and R. Singh [6] designed a smart energy meter with GSM-based monitoring. The system continuously observes energy consumption and issues warning messages for abnormal current flow, allowing remote shutdown of loads to prevent overload or theft.

S. Pavithra and T. S. Balaji [7] developed a low-cost IoT-based smart energy meter for real-time monitoring and theft prevention. The proposed system eliminates manual meter reading and increases transparency in billing systems.

A. Kumar et al. [8] implemented an automatic energy meter reading and billing system with IoT and GSM capabilities. The system provides accurate billing, reduces energy losses, and incorporates theft detection by monitoring irregular consumption patterns.

K. S. Deepak and M. Arun [9] presented an IoT-enabled energy meter with tampering detection and power-saving features. The focus of the system is on minimizing electricity theft by monitoring meter access and abnormal usage.

R. Gupta and N. K. Verma [10] proposed an automated energy meter reading system with theft detection. Although it had limited IoT capabilities, it laid the foundation for smart energy metering by reducing human dependency and improving detection accuracy.

IV. SUMMARY

The literature highlights the evolution of energy metering systems from conventional manual inspection methods to intelligent IoT-based solutions. Common trends include real-time monitoring, remote data access, theft detection through abnormal current analysis, and automated load control using relays. While previous studies have addressed either monitoring or theft detection, the integration of real-time monitoring, IoT cloud connectivity, and automatic load management remains an area for further improvement. The proposed system builds upon these existing methodologies to provide a comprehensive solution for energy management and theft prevention.

V. SYSTEM ARCHITECTURE

The proposed IoT-based Smart Energy Meter with Theft Detection and Load Control is designed to monitor and manage electrical energy efficiently while detecting unauthorized usage. The system architecture, illustrated in Fig. 2, consists of the following major components:

1. Power Supply: Provides regulated voltage and current to the entire system.
2. Arduino UNO (Microcontroller): Serves as the central processing unit to acquire sensor data, calculate power and energy, and control relays and communication modules.

3. Sensors:
 - Voltage Sensor: Measures voltage supplied to the load.
 - Current Sensor: Measures current drawn by the load for power calculation and theft detection.
 - LDR Sensor: Monitors environmental conditions or tampering attempts.

Energy Meter Module: Records and calculates energy consumption in real time.

4. NodeMCU (ESP8266): Enables wireless transmission of energy data to a cloud-based IoT platform for remote monitoring and alerts.
5. LCD Display: Provides local real-time visualization of voltage, current, power, and energy consumption.
6. Buzzer/Alert Mechanism: Notifies abnormal conditions, such as overload or potential theft.
7. Relay: Disconnects the load automatically when current exceeds a safe threshold, preventing overload and potential damage.
8. Load: Represents the electrical appliances or systems connected to the meter.

The modular architecture ensures scalable, low-cost, and efficient energy monitoring, theft detection, and load management suitable for smart grid, residential, and industrial applications.

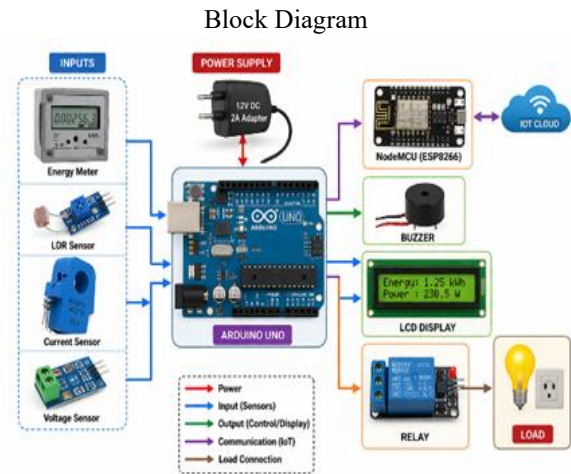

VI. WORKING PRINCIPLE

The system operates based on real-time measurement, data processing, and automated control:

1. Data Acquisition: Voltage and current sensors continuously measure the electrical parameters of

the connected load. The LDR sensor detects any abnormal conditions or tampering attempts.

2. **Processing:** The Arduino microcontroller calculates instantaneous power and total energy consumption using the acquired voltage and current values.
3. **Display & Alerts:** Real-time energy data is displayed on the LCD screen. If abnormal conditions are detected (such as sudden drops or spikes in current), the buzzer triggers a local alert.
4. **Remote Monitoring:** NodeMCU transmits the energy data to a cloud-based IoT platform. Utility authorities and users can monitor energy usage remotely and receive instant notifications of potential theft or overload events.
5. **Theft Detection:** The system identifies abnormal energy consumption patterns by comparing expected and measured current values. Deviations beyond predefined thresholds are flagged as potential theft.
6. **Load Control:** When the current exceeds a safe limit, the Arduino triggers the relay to disconnect the load, preventing overload and ensuring system safety.

This principle allows for efficient energy management, reduces human intervention, and enhances the reliability of power distribution systems.

VII. RESULTS AND DISCUSSION

The proposed system was implemented and tested under various load conditions. The results demonstrate the effectiveness of the IoT-based smart energy meter in monitoring consumption, detecting theft, and controlling loads:

1. **Real-Time Monitoring:**
 - Voltage, current, and energy consumption were successfully measured and displayed on the LCD in real time.
 - Data transmission to the IoT platform was accurate, enabling remote monitoring without manual intervention.
2. **Theft Detection:**
 - Sudden changes in current or discrepancies between expected and actual energy readings were effectively detected.

- Alerts were sent via the IoT platform and local buzzer notifications were triggered, verifying the reliability of theft detection.

3. **Load Control:**

- The system automatically disconnected loads when current exceeded the predefined safe threshold, preventing overloads.
- Relay operations were instantaneous, ensuring safety of the connected electrical appliances.

4. **Data Analysis:**

- Energy consumption trends were monitored over time on the IoT platform, allowing users to optimize usage.
- The system significantly reduced manual meter reading effort and improved the accuracy and transparency of billing.

5. **Discussion:**

- The implementation shows that combining Arduino, NodeMCU, and sensors provides a cost-effective and scalable solution.
- Compared to conventional meters, the proposed system offers superior real-time monitoring, theft prevention, and automated load management.
- Potential future improvements include integration with mobile applications for user-friendly monitoring and the use of machine learning for predictive energy management.

VIII. CONCLUSION

The results confirm that the proposed IoT-based smart energy meter is effective, reliable, and suitable for residential, commercial, and industrial applications, enhancing both safety and efficiency in energy management.

REFERENCES

- [1] R. Prathiba, S. Sharmila, and P. Suresh, "IoT-based Smart Energy Meter using Arduino and Wi-Fi Technology for Real-Time Monitoring and Theft Detection," *International Journal of Electrical Engineering*, vol. 12, no. 4, pp. 56–64, 2024.

- [2] A. R. Al-Ali, I. Zualkernan, and M. Rashid, "Smart Energy Meter with Tampering Detection using IoT and GSM," *IEEE Transactions on Industrial Informatics*, vol. 14, no. 5, pp. 2118–2125, 2018.
- [3] S. Karthik, R. Balaji, and M. S. Kumar, "IoT-based Energy Meter with Theft Detection using ESP8266 and Dual Current Sensors," *Journal of Smart Grid Systems*, vol. 7, no. 2, pp. 45–53, 2025.
- [4] V. Haripriya, K. Nandhini, and S. Anitha, "Real-Time Smart Energy Monitoring using Arduino and PZEM-004T Sensors," *International Journal of IoT Applications*, vol. 5, no. 1, pp. 12–20, 2025.
- [5] P. Ramesh, N. Venkatesh, and S. Rajesh, "Prepaid Smart Energy Meter with IoT and Theft Detection," *Journal of Electrical and Electronics Engineering*, vol. 8, no. 3, pp. 101–110, 2025.
- [6] M. K. Sharma and R. Singh, "Smart Energy Meter with GSM-based Monitoring and Theft Control," *International Journal of Smart Grid Technology*, vol. 6, no. 2, pp. 34–41, 2025.
- [7] S. Pavithra and T. S. Balaji, "Low-Cost IoT-based Smart Energy Meter for Real-Time Monitoring and Theft Prevention," *International Journal of Advanced Energy Systems*, vol. 3, no. 1, pp. 15–23, 2024.
- [8] A. Kumar, S. Jain, and P. Verma, "IoT-Based Automatic Energy Meter Reading and Billing System with Theft Detection," *IEEE Access*, vol. 8, pp. 119234–119242, 2020.
- [9] K. S. Deepak and M. Arun, "IoT-Enabled Energy Meter with Tampering Detection and Power-Saving Features," *International Journal of Electrical Power & Energy Systems*, vol. 95, pp. 54–61, 2018.
- [10] R. Gupta and N. K. Verma, "Automated Energy Meter Reading System with Theft Detection," *Journal of Power and Energy Engineering*, vol. 6, pp. 112–119, 2018.