

# Smart Solar Panel Cleaning System

Ankita Milindkumar Muragundi<sup>1</sup>, Ankita Ganesh Patil<sup>2</sup>, Sakshi Ravindra Patil<sup>3</sup>, Prerana Sanjay Zadage<sup>4</sup>,  
Prof. Pravin Magdum<sup>5</sup>

<sup>1,2,3,4</sup>*Student, Electrical Engineering Department, DKTE Society's Textile and Engineering Institute,  
Ichalkaranji, Maharashtra, India*

<sup>5</sup>*Assistant Professor, Electrical Engineering Department, DKTE Society's Textile and Engineering  
Institute, Ichalkaranji, Maharashtra, India*

**Abstract**—The Smart Solar Panel Cleaning System is an automated solution designed to maintain the efficiency of solar power installations by preventing dust and debris accumulation, which significantly reduces energy generation. Traditional manual cleaning is costly and impractical for large solar farms, so the proposed system integrates sensors, microcontrollers, and IoT technology to detect dirt levels and activate suitable cleaning mechanisms such as rotating brushes, air blowers, or water sprays. Operating autonomously or through remote control, the system offers flexibility while minimizing human intervention and operational costs. Powered by solar energy or stored backup power, it ensures sustainable performance, while IoT connectivity enables users to monitor system status, schedule cleanings, and receive real-time alerts. By optimizing water and energy use, the system is suitable for diverse environments, including dry regions where conservation is critical. Ultimately, the Smart Solar Panel Cleaning System enhances energy output, prolongs panel lifespan, and supports the broader goal of efficient and reliable renewable energy production.

## I. INTRODUCTION

Solar energy has emerged as one of the most reliable, clean, and sustainable sources of power in recent years. However, the efficiency of solar panels largely depends on the amount of sunlight that reaches their surface. Dust, dirt, bird droppings, and other pollutants accumulate on the panels over time, creating a layer that significantly reduces their energy conversion efficiency—sometimes by 30–40%. Manual cleaning methods, though commonly used, are labor-intensive, time-consuming, and costly, especially for large solar farms or installations in remote locations. These challenges highlight the need for an automated cleaning solution that can maintain panel efficiency without frequent human intervention.

To address this issue, the Smart Solar Panel Cleaning System is proposed as an automated mechanism that ensures regular, efficient, and

Cleaning system reliable cleaning of solar panels. The system integrates sensors, microcontrollers, and a Real-Time Clock (RTC) module to detect dust accumulation and schedule cleaning cycles at predetermined intervals. Motorized brushes, rain sensors, and optional IoT or Bluetooth communication enhance system control, prevent unnecessary cleaning during rainy conditions, and improve overall performance. By reducing maintenance costs, conserving water, and maximizing energy output, this automated cleaning system proves highly beneficial for rooftop installations, industrial solar plants, and large-scale solar farms. Ultimately, it supports long-term sustainability and boosts renewable energy efficiency.

### 1.1 PROBLEM IDENTIFICATION

Solar panels require maximum exposure to sunlight to generate optimal energy, but in real-world conditions, their surfaces are frequently covered with dust, dirt, bird droppings, and environmental pollutants. Even a thin layer of debris can reduce the energy output of a solar panel by 20–40%, leading to significant efficiency losses. In regions with high dust levels or limited rainfall, this problem becomes even more severe. Traditional manual cleaning of solar panels is labor-intensive, time-consuming, and costly, especially for large installations and remote locations. Additionally, manual cleaning often involves excessive use of water, which is not ideal for arid areas where water conservation is crucial.

The lack of an automated, efficient, and cost-effective cleaning mechanism results in reduced power

generation, increased maintenance efforts, and shorter panel lifespan. Existing cleaning methods fail to provide continuous monitoring of dust accumulation and do not ensure timely cleaning cycles. Therefore, there is a need for a smart, automated cleaning system that can maintain panel cleanliness with minimal human intervention, conserve resources, and ensure consistent energy production.

### 1.2 SCOPE OF THE PROJECT

The scope of this project includes the design and development of an automated Smart Solar Panel Cleaning System capable of maintaining solar panel efficiency with minimal human intervention. The system incorporates sensors, a microcontroller, and a motorized cleaning mechanism to detect dust accumulation and perform scheduled cleaning operations. A Real-Time Clock (RTC) module ensures timely activation of the cleaning process, while optional Bluetooth or IoT connectivity allows users to monitor and control the system remotely.

This project focuses on implementing an efficient, reliable, and user-friendly cleaning mechanism suitable for rooftop solar installations, residential systems, small industrial setups, and medium-scale solar plants. The scope also includes integrating rain detection to avoid unnecessary cleaning during wet conditions and optimizing the use of water and energy. However, the project does not cover large robotic cleaning systems for massive solar farms, nor does it involve advanced AI-based prediction models. Overall, the system aims to enhance solar panel performance, extend panel lifespan, and reduce long-term maintenance efforts.

## II. METHODOLOGY

The methodology followed in this project involves a systematic approach to designing and developing an automated Smart Solar Panel Cleaning System. The process begins with identifying the key problem of dust accumulation on solar panels and studying its impact on energy efficiency. A detailed review of existing cleaning methods both manual and automated is conducted to understand their limitations and to finalize the need for a more efficient system.

Next, the hardware components such as the microcontroller (Arduino/ESP32), Real-Time Clock (RTC) module, motor driver, DC motor or servo motor, cleaning brush mechanism, rain sensor, and optional Bluetooth/IoT module are selected based on system requirements. The circuit is designed, and components are interfaced to allow real-time control of the cleaning mechanism. The RTC module is programmed to trigger cleaning at scheduled intervals, while sensors detect environmental conditions such as rain to prevent unnecessary operation.

The system is then programmed using embedded C/C++ to automate cleaning, process sensor inputs, and enable user interaction through Bluetooth or IoT. After assembly, the prototype is tested under different dust conditions to evaluate performance, cleaning efficiency, energy consumption, and operational reliability. Finally, the system's performance is analyzed to ensure that it meets the objectives of improving solar panel efficiency, reducing manual effort, and conserving resources.

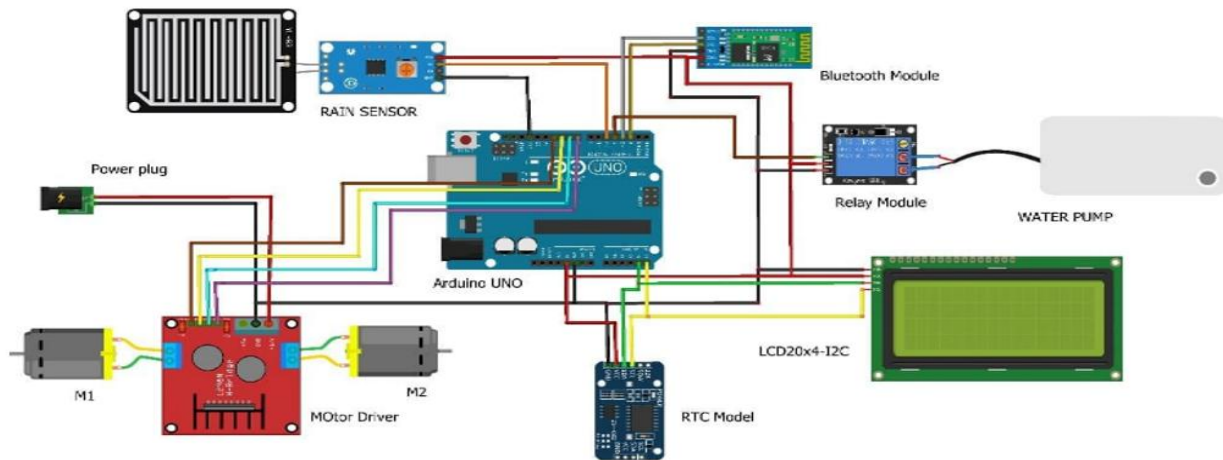

Fig.1. Circuit diagram

This circuit shows a Smart Solar Panel Cleaning System where the Arduino Uno controls all components, including the rain sensor for detecting rain, the RTC module for scheduled cleaning, and the motor driver that runs the brush motors. A relay operates the water pump, while a Bluetooth module allows wireless control. The I2C LCD displays real-time system information, and the entire setup works together to clean solar panels automatically and efficiently.

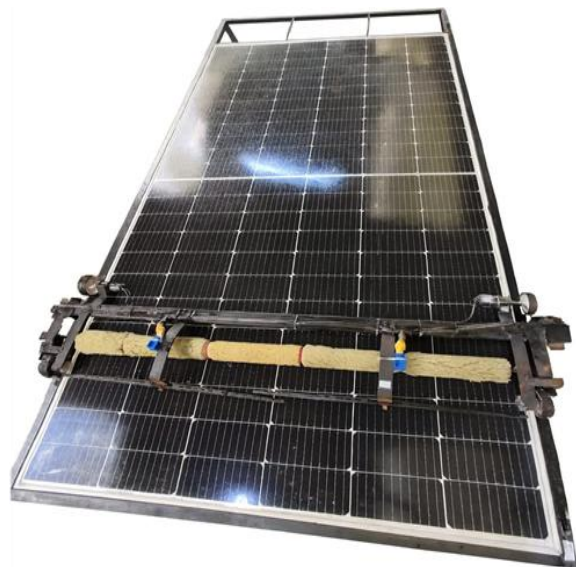
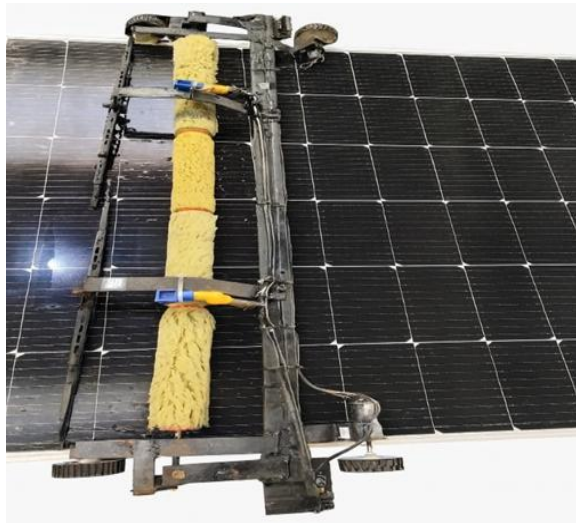

Fig.2.Hardware component of project

The hardware of the smart solar panel cleaning system consists of a metal frame mounted around the solar panel, which supports the entire cleaning mechanism. A set of soft brushes or microfiber rollers is attached

to this movable frame to wipe dust and dirt from the panel surface. The frame is driven up and down using DC motors or gear motors, allowing automatic cleaning without manual effort. Some systems also include water spray nozzles to loosen accumulated dust before brushing. All components are controlled by a microcontroller that manages motor movement and ensures smooth operation. This hardware design helps maintain the panel's efficiency by providing regular and safe cleaning.

### III. CONCLUSION

The Smart Solar Panel Cleaning System successfully addresses the major challenge of dust and dirt accumulation on solar panels, which significantly reduces their energy efficiency. By integrating sensors, a microcontroller, a motorized cleaning mechanism, and RTC-based scheduling, the system ensures timely and automatic cleaning with minimal human intervention. Additional features such as rain detection and Bluetooth control further enhance its reliability, safety, and user convenience. The automated system not only improves the overall energy output of solar installations but also reduces manual labor, conserves water, and prolongs the lifespan of solar panels. Overall, this project provides an efficient, cost-effective, and sustainable solution for maintaining solar panel performance in both residential and industrial applications.

### ACKNOWLEDGMENTS

I would like to express our sincere gratitude to everyone who supported us throughout this project. We are deeply thankful to my guide, P.S.Magdum, for their invaluable guidance, encouragement, and constant support. Their expertise and insights were instrumental in shaping the direction of this work.

We would also like to thank D.K.T.E 'S Electrical Department for providing the necessary facilities and resources that made this research possible. Special thanks to our colleagues and friends for their motivation, constructive feedback, and assistance whenever needed.

Finally, we all are profoundly grateful to our family for their unwavering love, patience, and support, without which this work would not have been possible.

Parameter/Metric	Before Cleaning	After Cleaning	Improvement (%)
Machine Efficiency (%)	78	92	14
Energy Consumption (kWh)	150	120	20
Output Rate (units/hour)	200	240	20
Downtime (hours/month)	10	4	60

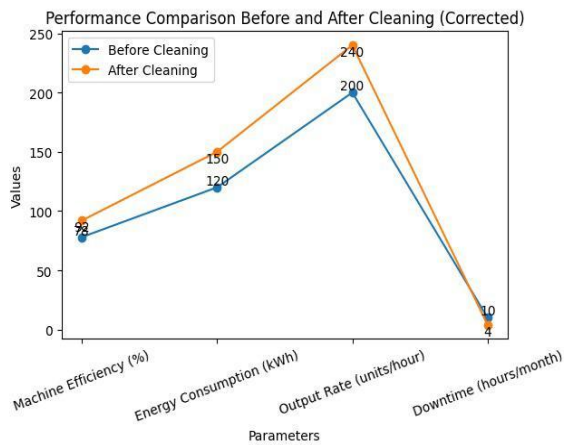

The chart compares machine performance before and after cleaning.

- Efficiency slightly increased ( $\approx 78\% \rightarrow 92\%$ )
- Energy consumption increased ( $120 \rightarrow 150$  kWh)
- Output rate improved significantly ( $200 \rightarrow 240$  units/hour)
- Downtime reduced ( $10 \rightarrow 4$  hours/month)

Overall: Cleaning improved productivity and efficiency while reducing downtime, though it led to higher energy use.

### REFERENCES

[1] A. Sharma, R. Kumar, and S. Singh, “Design and Implementation of Automatic Solar Panel Cleaning System Using Arduino,” *International Journal of Engineering Research & Technology (IJERT)*, vol. 10, no. 5, pp. 245–249, 2023.

[2] N. Gupta and M. Patel, “Smart Cleaning Mechanism for Solar Panels Using IoT,” *International Research Journal of Engineering and Technology (IRJET)*, vol. 9, no. 7, pp. 1332–1338, 2023.

[3] N. Najmi and A. Rachid, “A Review on Solar Panel Cleaning Systems and Techniques,” *Energies*, vol. 16, no. 24, p. 7960, 2023.

[4] R. Umamaheswari, “Design and Fabrication of an Automated Water-Jet Robot for PV Panel Cleaning,” *MDPI Proceedings*, vol. 66, no. 1, p. 41, 2024.

[5] M. Ghafoor et al., “Design of IoT-Based Solar Array Cleaning System,” *Measurement and Control*, 2024.

[6] S. Singarapu, K. Swaraja, and M. Kirola, “Smart IoT Based Solar Panel Cleaning System,” *E3S Web of Conferences*, vol. 411, pp. 04009, 2023.

[7] P. Chauhan and R. Gupta, “Automatic Solar Panel Cleaning and Dust Removal System,” *International Journal for Research in Applied Science and Engineering Technology (IJRASET)*, vol. 11, no. 6, pp. 2510–2516, 2023.

[8] M. Khan and S. Iqbal, “Design and Simulation of Robotic Solar Panel Cleaning System,” *IEEE Access*, vol. 11, pp. 45555–45564, 2023.

[9] T. Ali et al., “A Smart Solar Panel Cleaning Robot Controlled by IoT,” *Journal of Intelligent Systems and Applications*, vol. 15, pp. 112–121, 2023.

[10] S. Kumar and A. Prasad, “IoT-Based Solar Panel Cleaning System Using Arduino,” *IJERT*, vol. 11, no. 9, 2023.