

IoT-Enabled Intelligent Aquaculture Water Quality Monitoring

R. Durga Mohan Kumar¹, V. Mani Venkata Santhosh², K. Lakshmi Charan³, K. Vishnu Priyanka⁴, T. Venkateswara Reddy⁵

^{1,2,3,4,5} Department of electronics and communication engineering, sasi Institute of Technology and Engineering, Tadepalligudem, India

Abstract— *Aquaculture produces food on a global scale as a food source, however managing water quality is one of many significant issues that aquaculturists face. To address these issues, we propose an intelligent aquaculture monitoring system utilizing the LPC1768 and ESP32 microcontrollers and IoT technology. The system allows for onsite and remote monitoring of several parameters in aquaculture systems (temperature, humidity, pH levels, turbidity, dissolved oxygen and water level). The information collected from sensors is processed by the microcontrollers and displayed locally on a LCD screen for onsite monitoring and uploaded to Zoho's IoT cloud service for offsite monitoring and analysis purposes. The development of this system facilitates fewer daily manual actions, improves accuracy of monitoring, and provides timely decision-making. The experimental results demonstrate reliable operation and the continued consistency of the water quality parameters required to sustain aquaculture.*

Keywords— *IoT, LPC1768, ESP32, LCD Display, pH Sensor, Turbidity Sensor, Dissolved Oxygen.*

I. INTRODUCTION

The importance of aquaculture to food production globally is immeasurable. It offers us a sustainable source of fish and aquatic organisms. To ensure optimal growth and survivability of all aquatic species, it is critical to maintain water quality. There are many environmental parameters that influence the health of aquatic organisms. These include temperature, humidity, pH, turbidity, dissolved oxygen levels and water levels. Each of these parameters needs to be continually monitored in order to maintain a stable and suitable environment for all aquatic organisms. If there is an imbalance between the parameters previously mentioned, it can greatly affect aquatic life and lead to reduced production and an economic loss.

Water quality is usually monitored using traditional methods that require a manual approach, which includes regular human intervention. Traditional monitoring methods are considered to be time-consuming, inaccurate and do not provide real-time data for monitoring the water quality. As such, it can be difficult to take quick corrective actions due to changes in the water quality. The advent of new technologies such as the Internet of Things (IoT) will provide solution to the above challenges and allow for

continuous monitoring of water quality and remote access to the data, thereby greatly improving efficiency and reliability of monitoring.

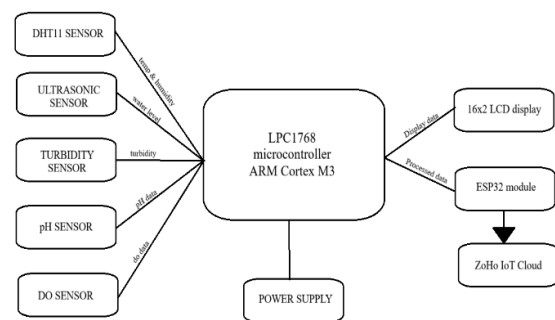

Figure 1. Block Diagram of Proposed System

This paper proposes an Intelligent Aquaculture Water Quality Monitoring System that uses Internet of Things (IoT) technologies (LPC1768 microcontroller and ESP32 for real-time data transfer). Multiple sensors (temperature, humidity, pH, turbidity, dissolved oxygen, and water level using ultrasonic sensor) are utilized in order to monitor water quality accurately. Data collected will be processed using the LPC1768 microcontroller and sent through the ESP32 to Zoho IoT Cloud Platform, where it can be remotely accessed by users at any time and from any location.

The proposed system reduces labor, improves accuracy of monitoring, and improves users' ability to make better decisions based on real-time monitoring and remote access. This type of intelligent monitoring system will help aquaculture managers manage their facilities more effectively through efficient aquaculture management and promote sustainable practices.

Many current systems do not combine all these capabilities (multiple sensors with efficient real-time cloud monitoring), which is why this project was initiated.

II. LITERATURE SURVEY

In recent years, there have been many improvements in aquaculture and monitoring systems using the Internet of Things (IoT) to help improve productivity through enhanced management of water quality. For example, a system developed by P. Selvan et al. [1] is capable of

monitoring and capturing real-time, quality data on such parameters as pH, temperature, turbidity (cloudiness), and level of water through a cloud-based application. Likewise, a study conducted by Arthi et al. [2] developed an Arduino-based monitoring system designed to not only monitor the pH, turbidity, temperature, and water level, but also include features for automated feeding of their fish and controlling the water using pumps and servos.

A literature survey performed by Swetha et al. [3] reviewed all available IoT-enabled monitoring systems that covered various parameters such as pH, conductivity, turbidity, and dissolved oxygen, as well as some of the environmental issues associated with aquaculture. This survey also included an overview of the study performed by Pateriya et al. [4] who created a system that measured and provided real-time measurement data for pH, temperature, dissolved oxygen, and ammonia levels and allowed for immediate notification to users via a mobile application. Another study [5] showed that there is considerable value in using sensors in aquaculture that send their data to the cloud for effective real-time monitoring.

A number of researchers have devoted their attention primarily toward developing better systems and usability of those systems. Huang et al. [6] postulated a LabVIEW system to allow for greater data visualization and improved accuracy of measurements. Tanim et al. [7] created an IoT-based system that will monitor all of the necessary parameters of fish production as well as to enable automated processes to aide in the production of fish. Similarly, Dănilă et al. [8] developed a monitoring system that is connected to the cloud that will provide a constant stream of data regarding parameters such as pH, dissolved oxygen, turbidity, and nitrates.

Kannan et al. [9] developed an automated monitoring system that measured temperature, water level, and pH, while also providing the opportunity to take corrective actions to minimize the amount of loss incurred by the fish. A different study [10] integrated automatic feeding, continuous monitoring, and secure data management into one network or system. Study [11] further expanded on the concept of Industry 4.0-based aquaculture support systems, where IOT is used in conjunction with Artificial Intelligence and Machine Learning to facilitate efficient and sustainable production of fish.

Bhatnagar and Devi, [12] created an IoT-driven aquaponics dataset using ESP32 and multiple sensors that allow for real-time monitoring and cloud analysis to facilitate better decision-making. Findings from the [13] study identified the optimal quality of water for the healthy development of fish. Work done by [14] and [15] suggests the application of IoT devices, such as Arduino, Raspberry Pi, and wireless sensor networks, to reduce manual effort and improve their operations. While all of the above studies have demonstrated significant strides in the advancement of IoT in aquaponics there continues to be the opportunity for enhanced analytical capabilities and fully automated

systems to provide a more comprehensive and intelligent solution to the industry.

III. PROPOSED SYSTEM & METHODOLOGY

A system to monitor water quality of aquaculture systems in real-time using multiple sensors connected via IoT.

The different sensors being utilized in this case include a DHT11, pH, turbidity, dissolved oxygen, and ultrasonic sensor. These sensors are capable of providing an accurate measurement of a variety of key physical and chemical properties of the water, which include temperature/humidity, pH acidity, water clarity, dissolved oxygen content, and water levels. By integrating the data from all of these sensors, the system will have an accurate and comprehensive assessment of the aquatic environment.

When the system initializes each component in the system, including the sensors, LPC1768 microcontroller; ESP32 Wi-Fi; 16×2 LCD, to ensure that they are functioning correctly. After all of the components are initialized, the system collects data from the water body.

The raw data collected from the sensors is processed by an LPC1768 microcontroller. During this processing of the data from the sensors, the raw data is converted into standard and interpretable measurement formats (units) in order to provide accurate measurements for use in monitoring and analyzing the water quality. After the processed data is ready, it is sent from the LPC1768 microcontroller to the ESP32 via UART for transmission to a remote location.

The ESP32 is the communication link for the system to connect to the internet. Once the processed data is uploaded to the Zoho IoT platform, users can view and analyze their water quality data remotely, as well as see historical trends. Users will be able to make better decisions and provide faster responses due to the remote access.

The system also provides a local display for data visualization using a 16×2 LCD display, which shows real-time parameter values for on-site viewing.

To improve reliability, the system continuously compares the sensor readings against the defined threshold values. If any parameter exceeds the threshold values, this indicates that a potential hazard exists in the aquatic environment; thus, the user can intervene in a timely manner.

Overall, the system is continuously monitoring water quality due to the continuous cycle of operation. By providing both real-time and remote access to data, the system supports effective management and maintenance of optimal conditions for aquatic organisms.

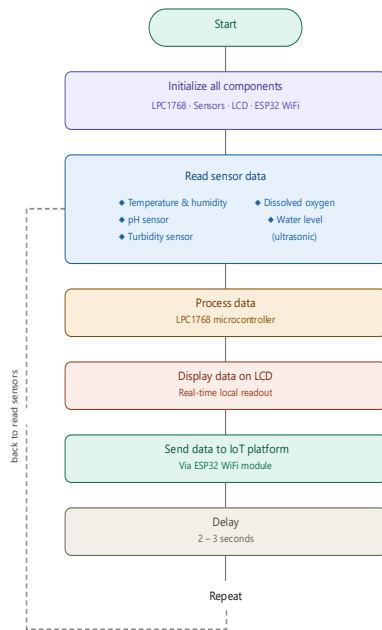

Figure 2. Flowchart of System Operation

IV. RESULTS AND DISCUSSION

The implementation of the IoT-based aquafarming monitoring system has been accomplished through completed testing of the device in real-time. The actual measurement for each of the variate water quality parameters assessed was taken during each time period of the project's procedure. In summary, the water qualities that were tested can be found in Table I WATER QUALITY PARAMETER

Parameter	Observed Range	Status
Temperature	27–28.5°C	Optimal
Humidity	68–70%	Stable
pH	5.9–7.0	Neutral
Turbidity	0–507 NTU	Good
Dissolved Oxygen	6–20 mg/L	High
Water Level	Low–Medium	Acceptable

All parameters tested during the study had values that met the acceptable limits for aquaculture practices. Temperature and humidity remained consistently stable, indicating optimal environmental conditions for aquatic organisms. The measured pH was close to neutral; this is critical to maintaining fish health over time. Turbidity levels reflected good water quality (clarity). Water had sufficient levels of dissolved oxygen to sustain aquatic life.

Using an ultrasonic sensor, the sensor system successfully determined the level of water fluctuation and managed the resource accordingly. Real-time data produced by the system were displayed on an LCD, also uploaded to the Zoho IoT cloud platform using ESP32; therefore, it allowed for effective remote monitoring.

Data graphically analyzed from cloud storage indicates that the sensor system can provide continuous and accurate real-time monitoring by reducing the time it takes to manually intervene with actions/decisions related to aquaculture. The integration of IoT technologies resulted in reduced manual intervention and improved cognitive decision-making. The sensor systems were demonstrated to be reliable, efficient, and effective for use in intelligent aquaculture applications due to their stable readings, low latency, and high accuracy within a reasonable timeframe.

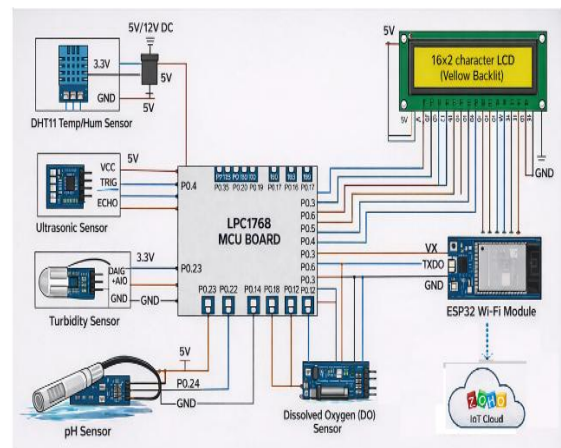

Figure 3. Hardware Prototype of IoT-Based Aquaculture Monitoring System

The diagram in Figure 3 illustrates how we have implemented this type of system from hardware perspective as an Internet Of Things (IoT) based system to monitor aquaculture. This system consists of an LPC1768 Microcontroller interfaced with various sensors: a DHT11, a PH Sensor, a Turbidity Sensor, a Dissolved Oxygen Sensor, and an Ultrasonic Sensor. The data collected from these sensors is transmitted via WIFI using an ESP32 module to the Zoho IoT Cloud Platform. The Electrical Digital Display (LCD) continuously displays the values for each of the sensors allowing for real time monitoring of different water quality parameters. The graphical representation of the parameters monitored over a period of time also provides additional verification of the operation of the system.

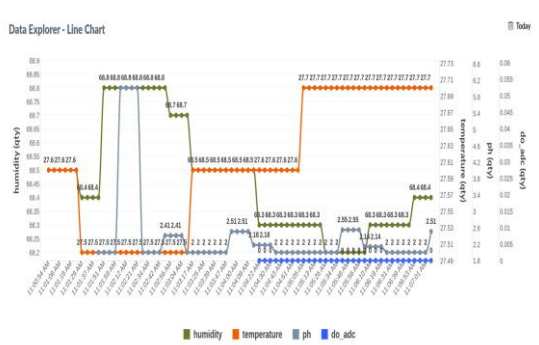

Figure 4. Real-Time Water Quality Parameters from Zoho IoT Cloud

The data above shows how different types of water quality characteristics (temperature, pH, turbidity, dissolved oxygen, and water level) varied over time using the Zoho IoT cloud and can be seen in Graph 4. Results of measured values fall into an acceptable range, indicating stable environmental conditions for fish farming, and that the system we developed is capable of accurately providing continual and reliable monitoring.

V. CONCLUSIONS

An IoT aquaculture water quality monitoring solution has been built to measure, monitor and log the water quality parameters of temperature, humidity, pH, turbidity, dissolved oxygen and water depth using an LCP1768 and ESP32 based system. All sensor readings will be taken and processed through the microcontroller, displayed on an LCD for local observance and sent to the Zoho IoT Cloud for remote access. The advantages of using this solution include more accurately monitoring water quality parameters, less manual work involved in monitoring and controlling water quality parameters to maintain constant environmental conditions. Future work on this solution will include mobile notification alerts, automated control of water quality parameters and machine learning capabilities to provide predictive analysis of water quality.

REFERENCES

[1] This paper discusses the application of IoT and wireless sensor networks to monitor aquaculture systems for fish farming in real time.

[2] The Internet of Things (IoT) allows for automated management of fish tanks through smart aquaculture monitoring systems.

[3] The purpose of this project is to create a low-cost digital monitoring system for smart fish farms that utilizes current technology.

[4] The recent advancements in IoT technologies will improve aquaculture operations by providing real-time data about aquatic environments.

[5] This paper presents an alternative method of monitoring and maintaining aquaculture ecosystems using IoT-based devices and systems.

[6] The goal of this project was to design a system for monitoring and controlling the environment of an aquaculture facility.

[7] The research focused on how the use of sensors and IoT would benefit fish farming.

[8] Dănilă, A.B., Bălăceanu, C., Orza, O., Boşoc, S., Silion, M., & Suci, G. (2023). Smart electronic system monitoring fish tank water quality parameters. *Sensors*.

[9] Kannan, A. D., Lean, C. P., Li, C., Yuan, K. F., Kiat, N. P., & Khan, M. R. B. (2024). Improve fish quality and yield through an automated monitoring system for intensive aquaculture. *Malaysian Journal of Science and Advanced Technology*, 4(2), 159-168.

[10] Palconit, M. G. B., Concepcion II, R. S., Tobias, R. R., Alejandro, J., Almero, V. J. D., Bandala, A. L., Vicerra, R. P., Sybingco, E., & Dadios, E. (2021). Development of an Internet of Things based fish tank monitoring system. *IEEE*.

[11] Biazi, V. & Marques, C. (2023). Review on industry 4.0 based smart systems in aquaculture. *Aquacultural Engineering*, 103, 102360.

[12] Udanor, C. N., Ossai, N. I., Nweke, E. O., Ogbuokiri, B. O., Eneh, A. H., Ugwuishiwi, C. H., Aneke, S. O., Ezugwu, A. O., Ugwoke, P. O., & Christiana, A. (2022). Internet of Things labelled dataset for aquaponics fish pond water quality monitoring system. *Data in Brief*, 43, 108400.

[13] Bhatnagar, A. & Devi, P. (2013). Water quality guidelines for managing pond fish culture. *International Journal of Environmental Sciences*, 3(6).

[14] Saha, S., Rajib, R.H., and Kabir, S. (2018). An IoT based Automated Fish Farm Aquaculture Monitoring System. In *Proceedings of the ICISCE conference*.

[15] Karim, S., Hussain, I., Hussain, A., Hassan, K., and Iqbal, S. (2021). An IoT based Smart Fish Farming Aquaculture Monitoring System. *International Journal of Emerging Technologies*. 12(2): 45-53.