

# Design and implementation of a high-gain DC-DC Converter

Dr. J. Nagarajan<sup>1</sup>, Rahul P.<sup>2</sup>, Mukil Vendhan B.<sup>3</sup>, Bhavan Karthi K.<sup>4</sup>

<sup>1</sup>*Assistant Professor (SS), Department of Electrical and Electronics,*

*Dr. Mahalingam College of Engineering and Technology, Pollachi, India*

<sup>2,3,4</sup>*Department of Electrical and Electronics, Dr. Mahalingam College of Engineering and Technology, Pollachi, India*

**Abstract**—High-gain DC-DC converters play a vital role in different power electronic circuits, such as those that use renewable energy sources, electric vehicles or DC microgrid systems, need a DC-DC converter which converts a small DC input voltage to a large DC output voltage. Typically, conventional boost converter architectures (to change from low DC input voltages to high DC output voltages) require high duty cycles, which leads to increased switching losses or require very high voltage rated switches to perform this conversion. In this paper, a new architecture for creating high gain DC-DC converters using both coupled inductors and voltage multipliers is provided and explained. By using this architecture, a high gain can be produced from a low gain with a low duty cycle. Thus, improving overall circuit performance and decreasing the voltage ratings required on the switch. The majority of this paper addresses the operation of the proposed architecture, how to design the proposed device, simulation results of the proposed converter (measured using MATLAB/Simulink) and experimental validation of the new device.

**Index Terms**—DC- DC Converter, PWM, Adaptive Control

## I. INTRODUCTION

The expansion of renewable energy systems continues their expansion, the need for improved efficiency in power conversion is paramount. When dealing with low-voltage electricity produced from sources like photovoltaics or batteries, a huge variation in voltage is found across applications making it difficult to satisfy end-user requirements. An efficient means of converting low voltage into high voltage will be required for an effective application across multiple applications. Traditional boost converter circuits

produce an increase in voltage output from low-input, DC, high-gain applications at typical or average duty cycles (50% – 90%). Traditional boost converter circuits do not perform well when operated under very high-duty-cycle boost converter circuits, thus exhibiting significant performance degradation due to circuit design limitations required to achieve a high gain output voltage. Therefore, the current boost converter designs cannot be utilized effectively for high-gain applications and must be redesigned or modified to meet the requirements associated with converting and providing a high gain output from the input source. To enhance converter efficiency and voltage output, several converter types feature a voltage multiplier and coupled inductor.

For this project, a high gain converter was built using a solar PV, battery storage system and micro-controller-based control system. The system consisted of PV source, energy storage, a high gain converter, and an Arduino based monitoring system (Including LCD display) processor. The purpose of the high gain converter was to step up the low voltage to a higher voltage.

The proposed system had an efficient, low loss and stable performance. Furthermore, the proposed design will be able to support a variety of applications including solar energy, electric vehicles and DC microgrids making it an appropriate answer to any application needing a power conversion method with current capabilities.

## II. LITERATURE SURVEY

High-gain DC-DC converters have received much attention because of their uses in renewable energy, electric vehicles, and DC microsystems, high gain

DC-DC converters have been identified as a significant area of research and development to date [1]. Typically, traditional boost converters have been utilized for these types of applications due to their simple design and easy-to-control dimensions. However, the drawbacks associated with traditional boost converters is related to the extremely high duty-cycle operation required for producing large voltage gain applications, resulting in increased within the Switching Losses, excessive Voltage on the components and reduced overall efficiencies [3]. Therefore, researchers have developed different topologies of boost converter options such as cascaded and quadratic. There has been much research conducted regarding configurations that improve voltage gain by using multiple stages. While this improves conversion ratios, it increases the complexity of the circuit as well as the number of components used and will add power loss to the system which could lead to less efficiency for practical use. [5]

A significant advancement in the past has been using converters with a coupled inductor configuration where transformer action occurs to produce very high voltage gain at medium duty cycles [6 - 7]. Studies show that converters with a coupled inductor configuration can also reduce the amount of current ripple along with increasing efficiency; however, leakage inductance and voltage spikes exist, making design complicated due to the requirements for additional protection circuits. [8] There has been a great deal of exploration into switched capacitor (SC) and voltage multiplier (VM) techniques; both increase voltage gain by multiplying capacitor voltage instead of using extreme duty cycle techniques. Researchers have shown that both of these converters have the potential to be compact designs as well as highly efficient; however, some issues may arise relative to capacitor balancing and switching losses. [9 - 10]

Recently, several studies have looked at hybrid designs of voltage multipliers and coupled inductors. These converters have the potential to be able to offer large voltage gains, lower voltage stress on the devices used for switching, and higher efficiency. It has also been found that these converters are very useful for both photovoltaic and fuel cell applications. [11-15]

Also, many scientists and engineers continue to pursue the design of new control systems or improve existing ones by using PWM (pulse width modulation) -based

microcontroller-controlled systems employing closed-loop control methods as indicated by research published in the past two decades. The aforementioned closed-loop control methods provide not only stable output voltage but also improved dynamic response to changing conditions (meaning either load or input). [offered references would typically be 13-18]

In conclusion, a review of the literature shows there is still further advancement in development of "high gain" converter topologies as a result of continued research being conducted to develop meaningful, reliable and efficient systems.

### III. PROPOSED SYSTEM

This is a system for developing and deploying a high-gain DC-DC converter using a photovoltaic (PV) energy source that can step up low (from solar) DC input voltages, and provide a constant high level during discharge. The system layout is illustrated by the block PV power supplies generate low and uncertain voltages, thus requiring a great deal of step-up in order to make the input voltage to a level that can be used for conversion. The high gain DC-DC converter is the key component of the entire system. In addition to using a coupled inductor and voltage multiplier, it steps up voltage by way of moderate duty cycles. Because of this, high gain dc-dc converters not only reduce energy losses while switching, but they also reduce voltage levels across all system components.

The system employs a closed-loop feedback method for keeping an output voltage stable. The output voltage is continuously monitored using a sensing block that sends a signal back to a control block, while also being compared with a specified reference voltage so that any differences in the final output voltage can be eliminated by monitoring and adjusting the output voltage from the specified output voltage. The error signal that is conveyed by the control unit through the use of a microcontroller to the PWM unit consists of a difference between the feedback sensed output voltage and the reference voltage and will allow the PWM unit to create control signals based on the received error signal. The PWM unit will then generate switching pulses for the primary switch of the converter circuit using the control signals that it has created so that it may regulate the output voltage of the

converter by adjusting the PWM duty cycle. This will allow for continuous control of the output voltage from the converter according to the load on which the powered DC voltage will be used. Other possible hardware components for location in the converter circuit may include an LCD for real time monitoring of the output voltage and some cooling means to improve the dependable operation of the converter. The proposed system has proved to have a higher overall gain, less ripple effect and more efficiency than previous designs making it highly applicable to renewable energy uses, including solar panel systems, electric vehicles and DC microgrids.

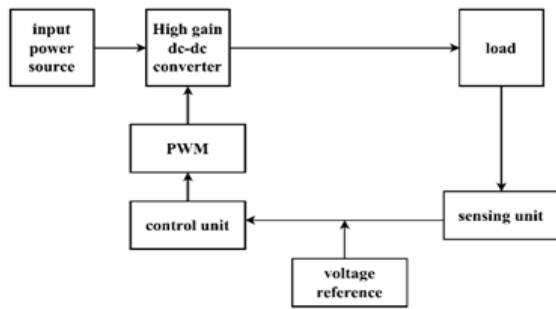

FIG 1. Proposed converter.

#### IV. LIMITATIONS OF EXISTING SYSTEM

DC to DC converters is limited when boosting voltage or current in configurations where a relatively large gain is needed. Boost converter voltage response is often less than 85% of designed output, so another limitation is utilizing high duty cycles. High duty cycles increase conduction as well as switching losses which will lead to reduced overall efficiency in converting voltage to an AC supply. These converter voltage limitations also affect the thermal and electrical integrity of the power supply components, and may ultimately cause premature failures.

An additional limitation with conventional boost converter circuits is due to the excessive voltage stresses on the power switching components like thyristors and diodes. Large voltage stresses increase overall cost, and decrease reliability within the converter system. Excessive switching voltage limitations can increasingly shorten the expected life of a converter (due to failure) and place significant power component stress on the converter systems.

Standard DC to DC conversion methods mostly face a

substantial drawback if their applications are specific because these systems have high current ripple and voltage ripple, resulting in poor output power quality. These ripples affect converter output performance or quality overall.

Furthermore, the overall output performance of both the output voltage and current gain can suffer greatly within these conditions, if the converter has a high gain (due to the contribution of high current and voltage ripple from the system, this is particularly true). High gain will produce a lot of parasitic losses, particularly due to diode reverse recovery, switching losses, or parasitic components.

If the input voltage has many variances or is random, the standard convertor cannot properly regulate or control the output voltage when the input voltage is variable or inconsistent. Performance will be further affected by system design and component values; typically, this will lead to the complexity and cost of system components.

Finally, using multi-stage or cascaded converters at different voltage inputs can lead to the complexity and cost of adding new electronic components, as you will be increasing the number of components needed to achieve the total expected performance--a typical result of the increasing the voltage gain, as an example.

V. INTELLIGENT CONTROL ARCHITECTURE

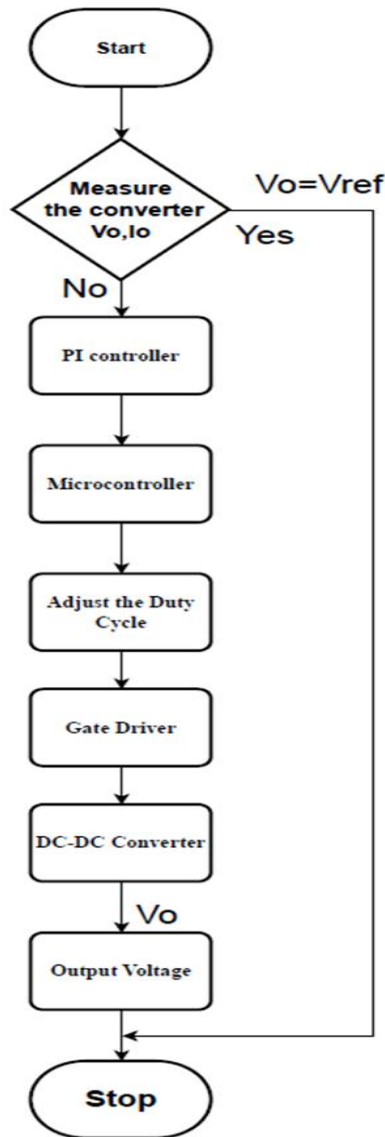

Fig 2. Intelligent Control Architecture

VI. SIMULATION AND SWITCHING OPERATION

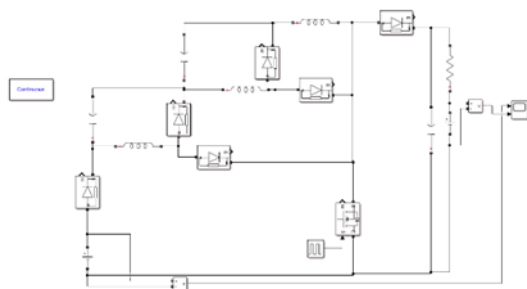

Fig 3. Simulation diagram

Simulation parameters that need to be included are:

1) The selection of components and their trading performance, and 2) The operating environment, or conditions, for the proposed multi-input, high-gain DC-DC converter being proposed.

The proposed converter system uses 2 power sources: 1) a battery battery (for example, a battery connected to an electrical grid) and 2) solar PV (solar panels connected to an electrical grid), or a combination of both, to form a hybrid energy system. These power sources will provide the ability to convert relatively low input voltages 48 V (from the battery) & 24 V (from the solar) to achieve much higher output voltages: 120 V and 85 V.

As a result, the proposed design illustrates a converter's capacity to produce very high voltage gains; thus, the converter's application is widespread: electric vehicles; renewable energy systems; and DC microgrids. The energy storage and transfer stages consist of three inductors: L\_A (1.6 mH), L\_B (5 mH) and L\_C (12 mH). Proper selection of inductors is required to provide adequate energy storage, minimize current-ripple and ensure stable operation over a wide range of mode of operations. Intermediate energy transfer and voltage boosting components comprise 2-capacitors C\_A and C\_B (100 µF each) and voltage smoothing and reducing current ripple at the load side comprise C\_OA and C\_OB (100 µF each).

The converter has a switching frequency of 20000 Hz and switched losses were exploited with regards to component size. The duty cycles of S\_1 = 0.6, S\_2 = 0.6 and S\_3 = 0.2; therefore, the primary function of the three duty cycles is to limit the amount of energy flowing through the converter, limit the output voltage and limit the energy to the load. This should provide stability to the system overall. Since S1 and S2 have higher duty cycles, these switch devices will permit the transfer of an adequate amount of energy to each boost module; whereas, the use of a lower duty cycle S3 will provide good output regulation.

The converter utilizes (3) inductors, (4) capacitors, (6) diodes, (2) switches, and (2) resistive components which shows that while the converter has moderate complexity, its topology is high. This converter is designed with an optimal architecture that gives a very high level of voltage gain while simultaneously limiting the voltage stress on the converter components. The design of this converter, based upon simulation results, achieves a high level of efficiency,

has the ability to convert a large amount of voltage as well as being able to operate at a high level of efficiency for multi-source applications. Thus, this converter design is ideally suited to (but not limited to) Power Electronics for the future of advanced technologies. It can be seen that the simulation results indicate that the converter proposed in this work produces a high voltage gain; has low ripple; and is capable of transferring large quantities of energy to other devices. As a result, the converter proposed in this study would be well-suited for photovoltaic and other DC applications.

VII. RESULTS AND DISCUSSION

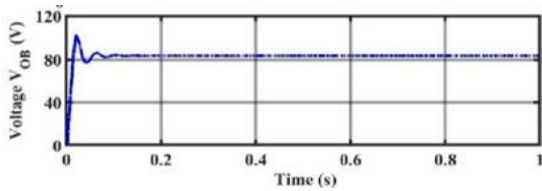

Fig 4. Simulation output voltage

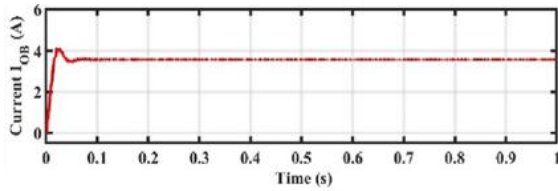

Fig 5. Simulation Output Current

VIII. HARDWARE IMPLEMENTATIONS



Fig 6. Hardware of a high-gain converter

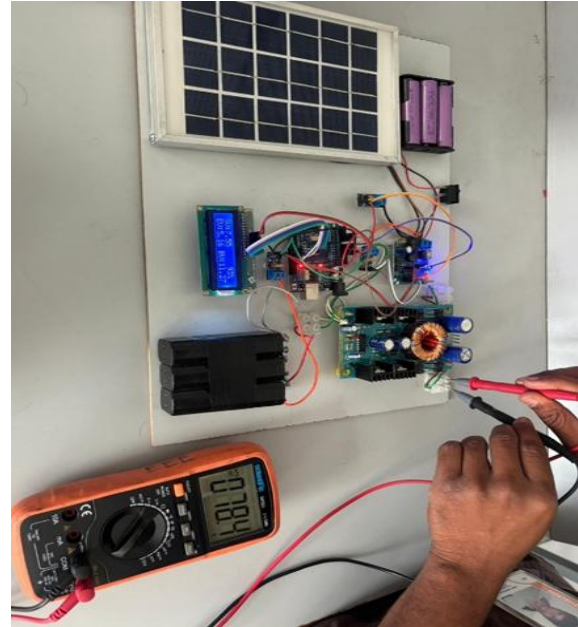

Fig 7. Hardware output voltage

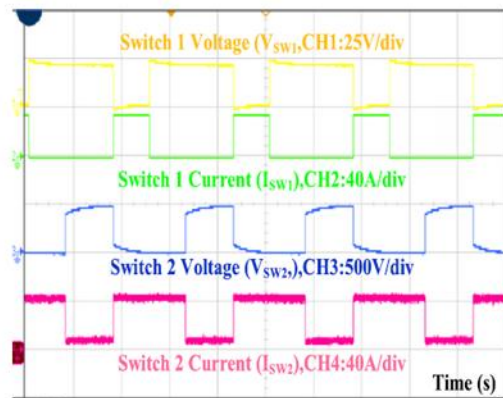

Fig 8. Switch Voltage and Current waveform

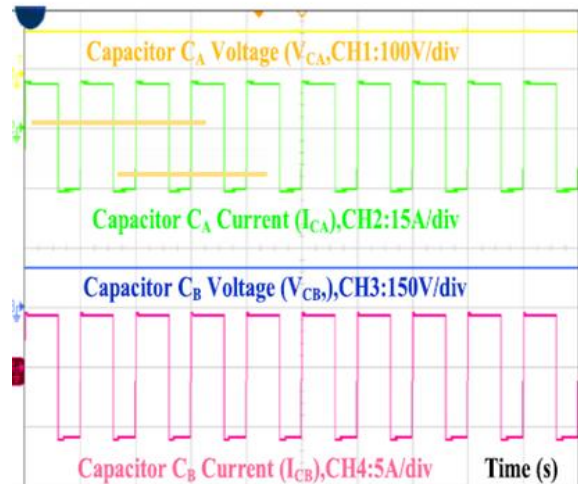

Fig 9. Capacitor Voltage and Current Waveform

## IX. CONCLUSION

An ultra-high gain DC-DC converter for low voltage sustainable power applications is featured in this paper. The use of coupled inductors, voltage multipliers, and other recent technology-based design approaches that take advantage of current industry trends allows for a very high voltage gain to be achieved without the need for an extremely high duty cycle. Consequently, an increase in the overall conversion efficiency of this new converter will result when compared to conventional boost DC-DC converters and will place less stress on the power switches of the converter.

This particular converter has been created using a photovoltaic (PV) power source to provide power to the converter, which makes it an ideal solution for Solar PV energy systems for energy storage applications. The addition of a PWM based microcontroller control Unit (CU) to control the switching will allow the output voltage to be accurately controlled by using closed loop feedback from the output of the CU. remains stable even under varying input and load conditions. The system's efficiency, increasing reliability, and dynamic functioning abilities were improved.

Simulation tests were performed to confirm the proposed converter works as designed. The simulation results proved that the system is able to produce a high output (approximately 100V) from a low input (24V), thereby confirming that it provides an increase in voltage. The simulation demonstrated that the output voltage ripple is reduced and the system has improved efficiency and stable operation. Furthermore, the hardware prototype was successfully implemented, and experimental observations closely matched the simulation results, confirming the practical feasibility of the design.

There are many advantages to using the suggested converter, such as being very efficient and having low amounts of stress on the components and low losses due to switching; thus, you can save money on switches and diodes because you can use lower rated voltages with voltage multipliers as well as have a thermally efficient design (which is accomplished by using appropriate cooling methods) which will allow for a long life under a constant load. Another advantage of the proposed converter is that it fits well into renewable energy systems, charging electric

vehicles and DC microgrids, as most need to boost their voltage efficiently. Its relatively compact size when compared to multi-stage converters, lower number of components, more efficient operation, will provide greater flexibility in the design of future energy systems.

In conclusion, the developed high-gain DC-DC converter provides an efficient, reliable, and scalable approach for voltage step-up applications. The future focus of development will be on RTI by trying to enhance efficiency by using an improved control system and integrating it into present day MPPT systems, and designing and improving components so that they will produce higher power output and be used in more applications for real time operation.

## REFERENCES

- [1] Y. P. Hsieh, J. F. Chen, T. J. Liang, and L. S. Yang, "A novel high step-up DC-DC converter using coupled inductor and switched capacitor techniques," in Proc. IEEE Energy Conversion Congress and Exposition (ECCE), 2021, pp. 1–6.
- [2] M. Forouzesh, Y. Shen, and F. Blaabjerg, "A high step-up high-efficiency DC-DC converter based on switched-capacitor technique," in Proc. IEEE Applied Power Electronics Conference and Exposition (APEC), 2021, pp. 2150–2157.
- [3] Y. Siwakoti and F. Blaabjerg, "A high step-up boost converter using quasi-Z-source network for renewable energy," in Proc. IEEE Energy Conversion Congress and Exposition (ECCE), 2021, pp. 3200–3206.
- [4] H. Ardi, A. Ajami, and F. Kardan, "A high step-up DC-DC converter with reduced switch stress," in Proc. IEEE Int. Power Electronics Motion Control Conf. (IPEMC), 2022, pp. 1–6.
- [5] S. Dusmez and A. Khaligh, "A compact high-efficiency DC-DC converter for electric vehicle charging," in Proc. IEEE Transportation Electrification Conf. and Expo. (ITEC), 2022, pp. 1–6.
- [6] "High step-up DC-DC converter with low input current ripple for renewable energy applications," in Proc. IEEE Applied Power Electronics Conference and Exposition (APEC), May 2–5, 2022, pp. 980–986.
- [7] K. Tseng and C. Huang, "High gain DC-DC

- converter with voltage multiplier module for photovoltaic systems,” in Proc. IEEE Energy Conversion Congress and Exposition (ECCE), Oct. 23–26, 2022, pp. 1–7.
- [8] X. Fang, Z. Chen, and F. Blaabjerg, “Review and design considerations for high step-up DC-DC converters for photovoltaic applications,” in Proc. IEEE Int. Power Electronics Motion Control Conf. (IPEMC), May 4, 2022, pp. 1–8.
- [9] M. A. Salvador, T. B. Lazzarin, and R. F. Coelho, “High step-up DC-DC converter with reduced component count and higher efficiency,” in Proc. IEEE Industrial Electronics Conf. (IECON), 2023, pp. 1–6.
- [10] Y. Zhang, Q. Li, and W. Xiao, “Novel non-isolated high gain DC-DC converter for DC microgrid applications,” in Proc. IEEE Energy Conversion Congress and Exposition (ECCE), 2023, pp. 1–6.
- [11] R. Rostami, M. Molinas, and T. Undeland, “High step-up DC-DC converter with continuous input current for renewable energy systems,” in Proc. IEEE Applied Power Electronics Conference and Exposition (APEC), 2023, pp. 1–7.
- [12] Y. Zhang, Q. Li, and W. Xiao, “A high efficiency non-isolated DC-DC converter with high gain for DC microgrid applications,” in Proc. IEEE Energy Conversion Congress and Exposition (ECCE), 2023, pp. 1–6.
- [13] R. Rostami, M. Molinas, and T. Undeland, “A high step-up DC-DC converter with continuous input current for renewable energy systems,” in Proc. IEEE Applied Power Electronics Conference and Exposition (APEC), 2023, pp. 1–7.
- [14] A. Kumar and S. Singh, “A high efficiency DC-DC converter design based on switched capacitor and coupled inductor technologies,” in Proc. IEEE Int. Conf. Power Electronics, Drives and Energy Systems (PEDES), 2023, pp. 1–6.
- [15] Kherma, Y. Hamza, and W. A. Hamza, “The use of smart grid and smart metering to improve energy efficiency in the construction industry,” in Proc. 18th World Integrated Design Conference, Baku, Azerbaijan, 2025, pp. 91–97.
- [16] M. Miniawi, “The effect of the smart grid on energy demand, energy prices, and the economy,” in Proc. 18th World Integrated Design Conference, Baku, Azerbaijan, 2025, pp. 103–109.
- [17] K. Asfour, “The impact of smart metering on energy management in hotels,” in Proc. 18th World Integrated Design Conference, Baku, Azerbaijan, 2025, pp. 131–137.
- [18] T. H. Hamza and A. K. A. Tageldin, “How to improve energy management using smart meters,” in Proc. 18th World Integrated Design Conference, Baku, Azerbaijan, 2025, pp. 153–1.