

Review of Sub-Synchronous Resonance (SSR) Mitigation using Unified Power Flow Controllers (UPFC) in Series-Compensated Systems

Akshata Milind Thosar¹, Milind Madhav Thosar², Yug Milind Thosar³

¹Research Scholar, Department of Electrical Engineering, The Maharaja Sayajirao University of Baroda

²Assistant Professor, Faculty of Pharmacy, The Maharaja Sayajirao University of Baroda

³MTech student, Department of Electrical Engineering, IIT Bombay

Abstract— Sub-Synchronous Resonance (SSR) is a critical issue in power systems, particularly those with series-compensated transmission lines. This phenomenon, characterized by oscillatory energy exchange between electrical and mechanical components, can lead to equipment damage and system instability. This paper reviews the application of Unified Power Flow Controllers (UPFCs) for SSR mitigation in series-compensated systems. The operating principles of UPFCs are discussed, and a comprehensive overview of various control strategies and simulation studies reported in the literature is presented. The review highlights the effectiveness of UPFCs in damping SSR and improving the overall stability of power systems.

Index Terms— Damping, Power System Stability, Series Compensation, Sub-Synchronous Resonance (SSR), Unified Power Flow Controller (UPFC).

I. INTRODUCTION

The contemporary surge in global electrical energy demand has compelled a fundamental reassessment of how existing power transmission networks are utilized. Rather than relying solely on the construction of new physical lines—which involves significant environmental and economic hurdles—power utilities have increasingly adopted series compensation as a primary strategy for infrastructure optimization. By integrating series capacitors into long-distance transmission lines, the total inductive reactance of the circuit is effectively neutralized, which significantly boosts the power transfer limit and enhances the overall voltage stability of the grid [1]. However, this enhancement comes with a complex trade-off: the introduction of series compensation can

trigger a dangerous phenomenon known as Sub-Synchronous Resonance (SSR). This occurs when the natural frequency of the electrical network enters into an oscillatory energy exchange with the mechanical torsional modes of the turbine-generator set at frequencies residing below the nominal synchronous frequency [2].

If these sub-synchronous oscillations are left unmanaged, they can result in extreme mechanical stress on the generator shaft, leading to catastrophic equipment failure, such as cumulative shaft fatigue or instantaneous fracture [4]. The severity of these risks led the IEEE SSR Working Group to establish standardized “Benchmark Models” to facilitate a unified framework for the analysis of these unstable interactions and the subsequent development of reliable damping solutions [4], [5]. In recent years, advanced Flexible AC Transmission Systems (FACTS) have emerged as the most effective remedy for these stability issues. Among these, the Unified Power Flow Controller (UPFC) is distinguished as the most versatile and high-performing device. By providing a high degree of freedom through the simultaneous and independent modulation of line impedance, voltage magnitude, and phase angle, the UPFC serves as a comprehensive tool for grid management

[3], [11]. The unique back-to-back converter architecture of the UPFC enables the implementation of high-speed supplementary damping controllers that can effectively suppress resonant peaks [12].

This paper serves as an exhaustive review of the technological landscape surrounding UPFC-based SSR mitigation. It meticulously details the

fundamental mechanisms of sub-synchronous interactions, the core operating principles of UPFC architectures, and a comparative analysis of modern control strategies—such as modal control and dq decoupling—that have demonstrated high experimental and simulation-based accuracy in maintaining system stability [6], [9], [10].

II. SUB-SYNCHRONOUS RESONANCE (SSR)

SSR arises from the interaction between the electrical network and turbine-generator mechanical systems. Series compensation reduces the natural frequency, potentially resonating with torsional frequencies [4].

II.1. Mechanisms of SSR

- *Induction Generator Effect (IGE)*: Subsynchronous current induces a voltage reinforcing the current, leading to self-excitation [6].
- *Torsional Interaction (TI)*: Interaction between the network and mechanical shaft modes, causing fatigue damage [7].

II.2. SSR Analysis Methods

Methods include Frequency Scanning [8], Eigenvalue Analysis [9], and Time Domain Simulation [10].

III. UNIFIED POWER FLOW CONTROLLER (UPFC) AND GUPFC

The Unified Power Flow Controller (UPFC) represents the pinnacle of Flexible AC Transmission Systems (FACTS) technology due to its ability to control all fundamental parameters of power transmission. It operates by integrating two voltage-sourced converters (VSCs) that are coupled through a common DC-link capacitor, allowing for the bidirectional exchange of active power between the shunt and series branches.

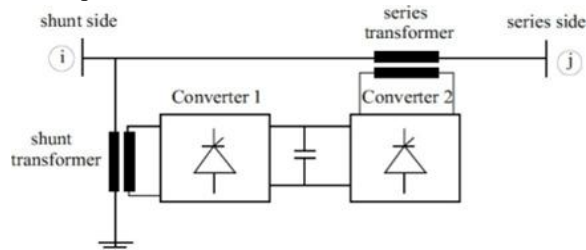

Figure 1: Architectural configuration of a UPFC showcasing the shunt and series transformer

interfaces.

As depicted in Fig. 1, the system architecture consists of a shunt-connected converter (Converter 1) and a series-connected converter (Converter 2). The series converter is responsible for injecting a synchronous AC voltage vector, V_{pq} , into the transmission line, which can be varied in both magnitude and phase angle to directly manipulate the line current and power flow. Simultaneously, the shunt converter serves a dual purpose: it regulates the DC-link voltage by absorbing or supplying the real power required by the series branch, and it provides independent reactive power compensation at the point of connection to maintain the local bus voltage.

III.1. UPFC Operating Principles

The operational flexibility of the UPFC stems from its ability to emulate a wide range of compensation characteristics. By precisely controlling the injected series voltage, the device can effectively shift the phase of the sending-end voltage or modify the effective impedance of the line.

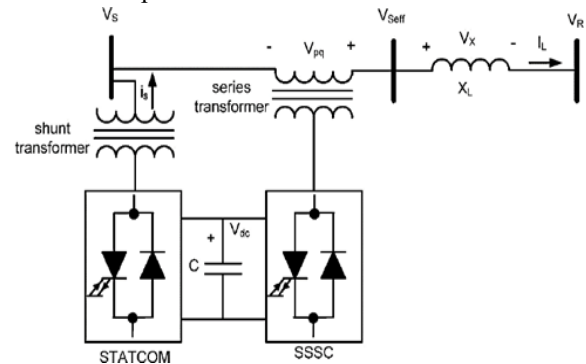

Figure 2: Functional block diagram of the UPFC operating as a combined STATCOM and SSSC.

As illustrated in the functional model in Fig. 2, the shunt component operates as a Static Synchronous Compensator (STATCOM), while the series component functions as a Static Synchronous Series Compensator (SSSC). The interaction between these blocks allows the UPFC to control the active and reactive power flow through the line reactance, X_L , by adjusting the effective voltage drop across the line. This allows the transmission system to operate much closer to its thermal limits without compromising stability.

III.2. UPFC Control Strategies for SSR Mitigation

While the primary function of the UPFC is steady-state power regulation, its high-speed response makes it an ideal candidate for mitigating Sub-Synchronous Resonance (SSR). This is typically achieved by superimposing a Supplementary Sub-Synchronous Damping Controller (SSDC) onto the main control loops.

Specific methodologies for SSR suppression include:

- Damping Torque Analysis: Utilizing frequency-domain techniques to ensure the UPFC provides a positive damping torque that counters the negative damping generated by series capacitors.
- Active Resistance Emulation: Programming the series converter to inject a voltage component that mimics a physical resistor at subsynchronous frequencies, thereby dissipating resonant energy.
- Modal Control Design: Employing advanced feedback signals, such as generator rotor speed deviation ($\Delta\omega$), to modulate the converter output and decouple mechanical-electrical interactions.

III.3. Generalized Unified Power Flow Controller (GUPFC)

The evolution of grid structures toward multi-line corridors led to the development of the Generalized Unified Power Flow Controller (GUPFC), which expands the UPFC concept to multi-line control.

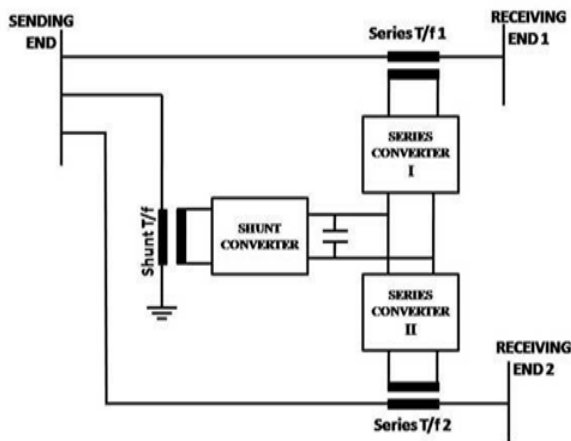

Figure 3: GUPFC configuration integrated into a multi-bus transmission system.

As shown in Fig. 3, the GUPFC utilizes a single shunt converter and multiple series converters (Series Converter I and II) sharing a common DC bus. This configuration allows the device to manage power

flow across two or more independent transmission lines originating from the same substation [cite: 1]. In the context of SSR, the GUPFC provides a significant advantage by facilitating "area-wide" damping [cite: 1]. It can dynamically redistribute power across different lines to move the system away from resonant operating points and provide coordinated damping torques to multiple generator units simultaneously [cite: 1].

IV. LITERATURE REVIEW OF SSR MITIGATION

The body of research surrounding Sub-Synchronous Resonance (SSR) mitigation using the Unified Power Flow Controller (UPFC) reveals a diverse range of analytical and control-based approaches. While early studies focused on general power stability, recent literature has shifted toward specialized control loops that address the unique mechanical-electrical interactions found in modern power grids. Table 1 summarizes the primary contributors and their respective strategies.

Table 1: Comparison of UPFC Control Strategies for SSR Mitigation

Author	Control Strategy	Key Methodology
Wang et al. [6]	Pole-assignment	Modal control
Abazari et al.[7]	Sensitivity	Damping torque
Zhu et al. [8]	SSDC Design	Time-domain
Jiang et al. [9]	<i>dq</i> decoupling	Line transfer
Ling et al. [10]	Modal control	$\Delta\omega$ feedback

A significant portion of the literature focuses on the integration of hybrid generation sources. For instance, Wang et al. [6] explored the complexities of damping oscillations in systems where traditional steam-turbine generators operate alongside offshore wind farms. Their research utilized a pole-assignment approach within a modal control framework, successfully stabilizing the varied resonant frequencies that emerge when disparate generation technologies are interconnected. This highlights the UPFC's adaptability in managing complex, multi-source power environments.

Another critical area of investigation involves damping oscillations without disrupting the primary power dispatch objectives of the utility. Abazari et al. [7] addressed this by implementing a control method based on the eigenvalue sensitivity theorem. This strategy allowed for effective suppression of sub-

synchronous currents while ensuring the steady-state power transfer remained constant. Similarly, Zhu et al. [8] provided rigorous verification of these supplementary damping blocks, using time-domain simulations to show that localized damping controllers could be added to existing UPFC units without requiring a complete overhaul of the primary control architecture.

Finally, the literature emphasizes the importance of selecting the correct feedback signals and converter components for optimal damping. Jiang et al. [9] conducted a comparative analysis of the UPFC's dual converters, discovering that the series inverter has a far more direct and potent impact on SSR damping than the shunt branch due to its ability to modulate line power transfer in real-time. This is often paired with mechanical feedback, as seen in the work of Ling et al. [10], who utilized generator rotor speed deviation ($\Delta\omega$) as a primary input signal. By feeding mechanical speed changes back into the modal control design, researchers have been able to significantly enhance the damping ratio of critical torsional modes, providing a robust defense against shaft fatigue.

V. FUTURE WORK

While significant progress has been made in utilizing UPFCs for SSR mitigation, several areas remain open for future investigation to align with the requirements of evolving smart grids:

- **AI and Machine Learning Integration:** Future research should explore the use of artificial intelligence and machine learning algorithms to design adaptive damping controllers that can autonomously adjust to varying grid topologies and fluctuating renewable energy penetrations.
- **Wide-Area Monitoring Systems (WAMS):** Integrating UPFC control loops with real-time data from Phasor Measurement Units (PMUs) could enable more coordinated, wide-area damping strategies to prevent cascading failures in large-scale interconnected networks.
- **Cyber-Physical Security:** As control systems become increasingly digitized, investigating the resilience of UPFC damping controllers against cyber-attacks and communication delays is a critical area for ensuring grid security.
- **Multi-FACTS Coordination:** Further studies are needed to analyze the interactions between multiple

FACTS devices (e.g., UPFCs, GUPFCs, and STATCOMs) operating in close proximity to avoid adverse control interactions and optimize global damping performance.

VI. CONCLUSION

This review has demonstrated that the Unified Power Flow Controller (UPFC) is one of the most effective and versatile solutions for addressing the challenges of Sub-Synchronous Resonance (SSR) in series-compensated transmission networks. By leveraging its dual-converter architecture, the UPFC provides the unique capability to simultaneously and independently modulate line impedance, phase angle, and voltage magnitude [3, 11]. This multi-variable control allows for the integration of supplementary damping controllers that can effectively suppress the unstable energy exchange between the electrical grid and the mechanical torsional modes of turbine-generators [8, 12].

Furthermore, the discussion on the Generalized Unified Power Flow Controller (GUPFC) highlights the evolution of these devices toward multi-line protection, offering a coordinated damping approach that is essential for maintaining stability in complex, interconnected power corridors [1]. Ultimately, the deployment of such advanced FACTS devices not only mitigates the risk of catastrophic equipment failure but also optimizes the power transfer capability of existing infrastructure, ensuring a more resilient and reliable power system.

ACKNOWLEDGMENT

The authors thank IIT Bombay for the resources to conduct this review.

REFERENCES

- [1] R. Thirumalaivasan et al., "Analysis of subsynchronous resonance with generalized unified power flow controller," *Int. J. Elec. Power*, vol. 53, pp. 623-631, 2013.
- [2] IEEE Committee Report, "Reader's Guide To Subsyn-chronous Resonance," *IEEE Trans. Power Syst.*, vol. 7, no. 1, Feb. 1992.
- [3] B. Fardanesh et al., "Multi-converter FACTS devices: the GUPFC," *IEEE PES Summer Meeting*, pp. 1020-1025, 2000.

- [4] R. G. Farmer, "Second Benchmark Model for SSR," *IEEE Power Eng. Rev.*, vol. PER-5, no. 5, May 1985. *IJIRT Formatting Guidelines*.
- [5] L. Wang et al., "Damping of SSR in a Hybrid System Using UPFC," *IEEE IAS Annual Meeting*, pp. 1-9, 2019.
- [6] S. Abazari et al., "Damping sub-synchronous oscillations using UPFC," *U.P.B. Sci. Bull.*, vol. 81, 2019.
- [7] X. ZHU et al., "SSR and its mitigation for power system with UPFC," *J. Mod. Power Syst. Clean Energy*, vol. 6, 2018.
- [8] H. Jiang et al., "Application of UPFC to mitigate SSR in series-compensated wind farms," *J. Eng.*, 2019.
- [9] J. Ling et al., "Design of UPFC SSR Damping Controller," *CICED*, pp. 1439-1443, 2018.
- [10] V. Chaudhary et al., "Power quality enhancement using UPFC," *ICCES*, pp. 2064-2069, 2019.
- [11] T. Priyankara et al., "Design and simulation of a UPFC," *i-PACT*, pp. 1-6, 2017.