

Smart Retractable Clothline System Using Iot

Dr. G. Rashmi¹, Abishek S², Kirthika K³, Subin S⁴

¹AP/EEE, ⁴Mar Ephraem College of Engineering and Technology, Elavuvilai, Kanniyakumari District, India-629171

^{2,3,4}Mar Ephraem College of Engineering and Technology, Elavuvilai, Kanniyakumari District, India-629171

doi.org/10.64643/IJIRTV12I11-201510-459

Abstract—The Smart Retractable Clothesline System is an automated solution designed to protect drying clothes from unexpected weather conditions, particularly rain. Traditional clothes drying methods require constant human supervision, which can be inconvenient and inefficient. This project integrates embedded systems and IoT technologies to create a responsive and user-friendly mechanism. The system utilizes a rain detection module to sense the presence of rainfall in real time. Upon detecting rain, a microcontroller such as the Arduino Uno processes the input signal and triggers a servo motor to retract the clothesline automatically, thereby preventing clothes from getting wet. In addition, a NodeMCU module is incorporated to enable wireless communication and IoT functionality, allowing users to monitor system status remotely through a web interface. The proposed system emphasizes energy efficiency, low cost, and ease of installation, making it suitable for residential applications, especially in urban environments with limited space. By combining automation with smart sensing and connectivity, the system enhances convenience, reduces manual effort, and ensures better protection of clothes during drying.

Index Terms—Internet of Things (IoT), Smart Home Automation, Clothesline System, Rain Sensor, ESP32, Automation.

I.INTRODUCTION

Clothes drying is an essential daily activity in households across the world. In most homes, traditional drying methods such as outdoor clotheslines or drying racks are commonly used because of their simplicity and low cost. However, these methods depend heavily on natural environmental conditions like sunlight and wind, making them unreliable in unpredictable weather. One of the major challenges of conventional clothes drying is the need for constant manual supervision. People

must monitor weather conditions to ensure their clothes are not exposed to rain or excessive moisture. This becomes inconvenient, especially for working individuals or those who are not always at home. Unexpected rainfall is a frequent issue in many regions, particularly in tropical areas such as Tamil Nadu, where sudden weather changes can occur without warning. As a result, clothes left outside may get wet, leading to wasted time, repeated washing, and unpleasant odors. The integration of the Internet of Things (IoT) further enhances the capabilities of such systems. IoT allows devices to communicate over the internet, enabling users to monitor and control them remotely. This adds convenience and improves efficiency. In recent years, smart home technology has gained popularity due to the increasing demand for automation and convenience. Home automation systems aim to simplify routine tasks, reduce human effort, and improve efficiency.

The Smart Retractable Clothesline System aligns with this trend by addressing a common household problem through intelligent automation. Energy efficiency is another key advantage of this system. Unlike electric dryers, which consume significant power, traditional clotheslines rely on natural resources such as sunlight and air. By integrating automation into this eco-friendly method, the system maintains low energy consumption while improving functionality. Weather unpredictability has increased due to changing climatic conditions, making manual judgment less reliable. Sudden rain showers can disrupt daily routines, particularly in regions with frequent seasonal variations. An automated system that responds instantly to environmental changes becomes highly beneficial.

II. EXISTING SYSTEM

The current system is mainly manual, requiring clothes to be hung on fixed or retractable lines without automation. It depends on constant human supervision, making it inconvenient during sudden rain or changing weather conditions. There is no sensing, decision-making, or remote monitoring capability, limiting efficiency and usability. Alternatives like electric dryers are energy-intensive and costly, highlighting the need for a smarter, automated solution.

III. LITERATURE REVIEW

Several studies and systems have been developed in the domain of home automation, including smart irrigation systems and automatic curtain controllers. However, limited attention has been given to automating clothes drying systems. Existing solutions mainly include manual retractable clotheslines or timer-based systems that lack real-time environmental sensing. Some systems provide rain alerts but do not include automatic actuation. The proposed system improves upon these limitations by integrating real-time sensing, automated control, and IoT connectivity, making it more efficient and user-friendly. Several researchers have explored automation in household systems using IoT to improve convenience and efficiency.

Smart home technologies such as automated lighting, climate control, and irrigation systems demonstrate how sensor-based monitoring and control can reduce human effort. In the context of clothes drying, some studies have proposed semi-automated systems that use rain sensors to alert users about weather changes, but these systems still require manual intervention to protect clothes. Other works have implemented motorized retractable mechanisms; however, they often lack integration with real-time environmental sensing or IoT connectivity. Recent advancements in IoT platforms have enabled systems to not only monitor but also control devices remotely through mobile applications. Some research has incorporated humidity and temperature sensors to optimize drying conditions, but these systems are primarily focused on indoor drying setups. Additionally, a few prototypes have used microcontrollers like Arduino or ESP8266

for automation, yet they often do not combine multiple environmental parameters such as light intensity, humidity, and rainfall simultaneously for decision-making. Therefore, there is a clear need for a fully integrated system that combines multi-sensor data, automated actuation, and IoT-based remote monitoring. The proposed Smart Retractable Clothesline System addresses these gaps by providing a comprehensive solution that ensures real-time response to environmental changes while offering user control through cloud connectivity. This makes the system more reliable, efficient, and suitable for modern smart home applications.

IV. PROPOSED SYSTEM

The proposed system consists of sensors, a microcontroller, a motorized mechanism, and IoT connectivity. Sensors such as rain, humidity, and light sensors continuously monitor environmental conditions. The microcontroller processes this data and decides whether to extend or retract the clothesline. If rain is detected or humidity is too high, the system automatically retracts the clothesline to protect the clothes. When sunlight is available and conditions are favorable, the clothesline extends again. The system is also connected to an IoT platform, allowing users to monitor and control it remotely through a mobile application.

V. SYSTEM ARCHITECTURE

The system architecture includes both hardware and software components working together. The hardware consists of a microcontroller (ESP8266 or ESP32), rain sensor, DHT11/DHT22 humidity sensor, LDR for light detection, a DC motor, and a motor driver such as L298N. The software includes programming through Arduino IDE and integration with IoT platforms like Blynk or ThingSpeak. The sensors collect data, which is processed by the microcontroller, and based on the output, the motor driver controls the movement of the clothesline. Data is also sent to the cloud for monitoring and notifications.

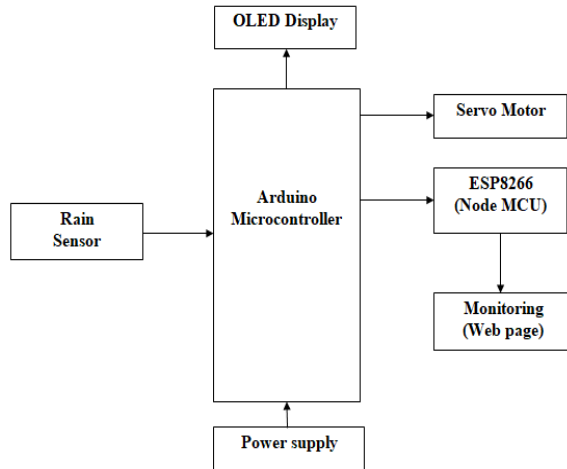

Figure1: Block diagram of smart retractable clothesline system using IoT

VI. ALGORITHM DETAILS

The system begins by initializing all sensors and establishing a Wi-Fi connection. It then continuously reads data from the rain, humidity, and light sensors. If rain is detected or humidity exceeds a set threshold, the system triggers the motor to retract the clothesline. If sunlight is detected and conditions are suitable for drying, the clothesline is extended. The system also sends real-time data to the cloud and repeats this process in a continuous loop to ensure timely response to environmental changes.

VII. RESULT ANALYSIS

The Smart Retractable Clothesline System was successfully designed and implemented, demonstrating effective automation in protecting clothes from unexpected rainfall. The system was tested under various environmental conditions to evaluate its performance and reliability. When water droplets were detected by the rain sensor, the microcontroller responded immediately by activating the servo motor to retract the clothesline.

The response time was observed to be quick and consistent, ensuring that clothes were protected from getting wet. The integration of the NodeMCU module enabled successful wireless communication, allowing real-time monitoring of the system through a web interface. Users were able to view the status of the clothesline (extended or retracted) and receive updates

remotely, confirming the effectiveness of IoT functionality.



Figure2: Hardware output of smart retractable clothesline system using IoT

The OLED display also provided accurate local feedback, making the system user-friendly even without internet access. The system proved to be energy-efficient and reliable, operating with minimal power consumption while maintaining stable performance. The use of simple and low-cost components made the design economical and suitable for residential use. Additionally, the automatic operation reduced the need for manual supervision, saving time and effort for users.

VIII. CONCLUSION

The Smart Retractable Clothesline System successfully demonstrates the application of automation and IoT technology in solving everyday household problems. The system effectively detects rainfall using a rain sensor and automatically retracts the clothesline through a servo motor, ensuring that clothes are protected from getting wet. The integration of the Arduino microcontroller provides reliable control, while the ESP8266 (NodeMCU) enables remote monitoring through a web interface. The developed system reduces the need for constant manual supervision, improves convenience, and enhances the efficiency of the clothes drying process. It is also cost-effective, energy-efficient, and easy to install, making it suitable for residential use, especially in urban environments with limited space. Overall, the project meets its objectives by providing a smart, reliable, and user-friendly solution for automated clothes drying.

IX.FUTURE WORK

The system can be further enhanced by integrating weather forecasting APIs to predict environmental changes in advance. Solar panels can be used to make the system more energy-efficient and sustainable. Artificial intelligence can be implemented to optimize drying patterns based on historical data. Integration with voice assistants such as Alexa or Google Assistant can also improve user interaction and convenience.

REFERENCES

- [1] W. A. Abdul Wali, A. R. F. Asmida, and H. Nasri, "Review on the AC Servomotor Control Systems," *A Review on the AC Servomotor Control Systems*, vol. 19, no. 2, pp. 22–39, 2020.
- [2] Bhuvan, *The Art of Agile Practice: A Composite Approach for Projects and Organizations*. CRC Press, 2016.
- [3] Ellyvon, "Kenapa Cuaca Tak Menentu Belakangan Ini? Kadang Panas Kadang Hujan," *Kompas.com*, 2021. Retrieved Mar. 17, 2021. Kompas
- [4] "Fenomena Cuaca," 2021. Retrieved Aug. 3, 2021. MetMalaysia
- [5] H. D. Herbert, "Production of Large Computer Programs," *IEEE Educational Activities Department*, vol. 5, no. 4, pp. 350–361, 1983.
- [6] Johnpaul, *Design and Implementation of a Rain Sensor as a Protective System*. Chukwuemeka Odumegwu Ojukwu University, 2018.
- [7] Jalanan, "Petanda Apabila Dunia Mengalami Cuaca Tidak Menentu," *Sinar Harian*, 2021. Retrieved Apr. 6, 2021. Sinar Harian
- [8] L. Leo, "Working Principle of Arduino Uno Using IT as a Tool for Study and Research," *International Journal of Control, Automation, Communication and Systems*, vol. 1, no. 2, pp. 21–29, 2016.
- [9] M. I. Mohamad, *Automated Clothesline System*, Bachelor of Engineering (Hons), Electrical & Electronics Engineering Programme, 2008.
- [10] M. Nasrulddin, A. A. Nurul Ashykin, N. H. Nik Syuhailah, and A. A. Zuraim, "Cyber Security in Supply Chain Management: A Systematic Review," *Scientific Journal of Logistics*, vol. 17, no. 1, pp. 49–57, 2021.
- [11] M. Muzaffar, Z. M. I. Danial, A. R. Nor Adawiyah, and I. Nurul Syafiqah, "Smart Hanger: Indoor T-Shirt Dryer," *Multidisciplinary Applied Research and Innovation*, vol. 2, no. 1, pp. 341–346, 2021.
- [12] Mazniha, A. H. S. N. Aisyah, N. Effa Nadzirah, and M. R. Nurin Faqihah, "Automatic Clothesline Retrieval Prototype with Humidity Alert System to Aid Clothesline Drawbacks for Reducing Laundry Worries," *Multidisciplinary Applied Research and Innovation*, vol. 2, no. 1, pp. 401–410, 2021.
- [13] Ooi W. L., *Hang-and-Go: A Smart Laundry Hanging System*, Bachelor of Technology dissertation, Universiti Teknologi Petronas, Tronoh, Perak, 2015.
- [14] O. B. Oktaf and E. L. Folkes, "Propose Design of Smart Clothesline with the Tree Diagram Approach Analysis and Quality Function Deployment Method for Indonesia Weather," in *Proc. Journal of Physics: Conference Series*, 2019.
- [15] Prabhakar, N. Sunil, A. Parashuram, and M. R. Kiran, "Automatic Protection of Clothes from Rain," *International Journal of Advanced Research in Computer and Communication Engineering*, vol. 5, no. 4, pp. 363–366, 2016.
- [16] V. Veeramany and A. Saal, "Rain Sensor for Detecting Rain or Other Material on Window of a Vehicle or Other Surface," U.S. Patent 7,516,002, Apr. 7, 2009.
- [17] Van Casteren, "The Waterfall Model and the Agile Methodologies," vol. 2, no. 2, pp. 1–6, 2017.